

# PROCEEDING



## First International Conference on Bio-**Materials** Science, **Mechanical** and **Electrical Engineering**

Scopus



THOMSON  
REUTERS®

11 - 12 DECEMBER 2024



City of Trades and Skills, Nador, Morocco

[icbmsm2e2024@gmail.com](mailto:icbmsm2e2024@gmail.com)

[bmmee2024.sciencesconf.org](http://bmmee2024.sciencesconf.org)

### Partners & Sponsors



جامعة سلوان



## Welcome Message from General Chairs

### Dear Colleagues, Scientists and Participants

It is our great pleasure to invite you from around the globe to join us for the First Edition of the International Conference on Bio-**Materials** Science, **Mechanical** and **Electrical Engineering** (ICBMSM2E'24), set to unfold in the city of Nador, Morocco, **December 11-12, 2024**.

This event plays a pivotal role in advancing knowledge and innovation across a wide range of fields, reflecting the multi-disciplinary and dynamic nature of modern science and technology. It spans areas such as materials science, electronics, mechanics, and electricity, while also embracing cutting-edge domains like artificial intelligence. Furthermore, the event addresses pressing challenges and opportunities in renewable energy technologies, including solar cells, photovoltaics, wind turbines, and fuel cells, as well as critical applications in civil engineering and beyond.

By fostering dialogue and collaboration among experts from these diverse disciplines, the event offers participants a unique platform to exchange ideas, share insights, and explore new directions for research and development. This gathering not only highlights the interconnectedness of these fields but also provides a fertile ground for sparking innovative solutions and building impactful collaborations that will shape the future of science and technology.

We hope to see you all in the vibrant city of Nador, to enjoy the event while exploring the charm of this coastal gem. Nestled between the Mediterranean Sea and the majestic Rif Mountains, Nador offers a unique blend of natural beauty and cultural richness. We extend a heartfelt welcome on this special occasion, promising an engaging, inspiring, and unforgettable experience.

Thank you, and we look forward to sharing this memorable journey with you!



**Pr. Mohamed Louzazni**

ENSA, Chouaib Doukkali University,  
El Jadida, Morocco



**Pr. Elhadi Baghaz**

FS, Chouaib Doukkali University,  
El Jadida, Morocco



**Pr. Ahmed Faize**

EST, Mohamed First University,  
Nador, Morocco



## Honor Committee



**Pr. Yassine Zarhloule**

President of Mohamed First University, Oujda, Morocco



**Pr. Az-eddine Azim**

President of Chouaib Doukkali University, El Jadida, Morocco



**Pr. Mohamed Atounti**

Director of the Higher School of Technology, Nador, Morocco



**Pr. Hafid Saber**

Dean of the Faculty of Sciences Chouaib Doukkali University, El Jadida, Morocco



**Pr. Abdelwahed Hajjaji**

Director of the National School of Applied Sciences, Chouaib Doukkali University, El Jadida, Morocco



**Pr. Ali Azdimousa**

Dean of the Multidisciplinary Faculty Nador, Morocco



**Pr. Khadija Haboubi**

Director of the National School of Applied Sciences in Al Hoceima

## General Chairs



**Pr. Elhadi Baghaz**

FS, Chouaib Doukkali University,  
El Jadida, Morocco



**Pr. Mohamed Louzazni**

ENSA, Chouaib Doukkali University,  
El Jadida, Morocco



**Pr. Ahmed Faize**

EST, Mohamed First University,  
Nador, Morocco

## General Co-Chairs



**Pr. Kamal Essifi**

FS, Chouaib Doukkali University,  
El Jadida, Morocco



**Pr. Abdelhamid Rebhi**

Picardie Jules Verne University  
Amiens, France



**Pr. Mohammed Barboucha**

Director of School of Advanced Engineering  
studies of Oujda, Morocco



**Pr. Fatima Majid**

FS, Chouaib Doukkali University,  
El Jadida, Morocco



**Pr. Kamal Hirech**

ESEF, Mohamed First University,  
Oujda, Morocco



Program and coordination committee



**Pr. Elhadi Baghaz**

FS, Chouaib Doukkali University,  
El Jadida, Morocco



**Pr. Kamal Essifi**

FS, Chouaib Doukkali University,  
El Jadida, Morocco



**Pr. Abdelqader  
El Guerraf**

FST, Hassan First University,  
Settat Morocco

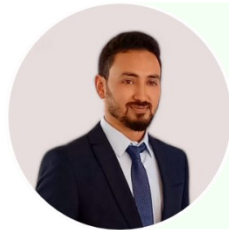

**Dr. El Mehdi Irzan**

FS, Chouaib Doukkali University,  
El Jadida, Morocco



**Dr. Fatima Ezzahra  
Arhouni**

FS, Chouaib Doukkali University,  
El Jadida, Morocco



**Dr. Hasnae Saadi**

FS, Chouaib Doukkali University,  
El Jadida, Morocco

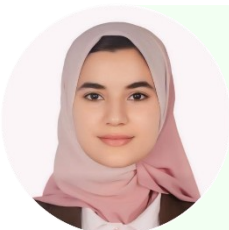

**Jihad El Makaoui  
(PhD student)**

FS, Chouaib Doukkali University,  
El Jadida, Morocco



**Nouhaila Benaissa  
(PhD student)**

FS, Chouaib Doukkali University,  
El Jadida, Morocco



**Toufik Hachimi  
(PhD student)**

FS, Chouaib Doukkali University,  
El Jadida, Morocco

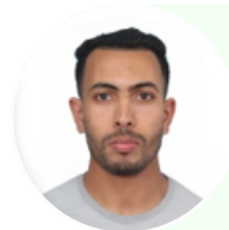

**Yassine El Alami  
(PhD student)**

FS, Chouaib Doukkali University,  
El Jadida, Morocco

## Organizing Committee

Pr Petru Adrian Cotfas	Transylvania University of Braşov, Romania
Pr Daniel Tudor Cotfas	Transylvania University of Braşov, Romania
Pr Charaf Hajjaj	Chouaib Doukkali University, El Jadida, Morocco
Pr Soufian Talbi	Mohammed First University, Morocco
Pr Said Laasri	Chouaib Doukkali University, El Jadida, Morocco
Pr Mohammed Lahlou	Chouaib Doukkali University, El Jadida, Morocco
Pr Fouad Belhora	Chouaib Doukkali University, El Jadida, Morocco
Pr Samira Touhtouh	Chouaib Doukkali University, El Jadida, Morocco
Pr Hamid Nasrellah	Chouaib Doukkali University, El Jadida, Morocco
Pr Mohamed El Bojaddaini	Mohammed First University, Morocco
Pr Fatima Majid	Chouaib Doukkali University, El Jadida, Morocco
Pr Abdelqader El Guerraf	Hassan First University, Settat, Morocco
Pr Said Dlimi	Chouaib Doukkali University, El Jadida, Morocco

## Organizing Committee- Docteurs

Dr. Brahim Belmahdi	Abdelmalek Essaadi University, Tetouan, Morocco
Dr. Sara Said	Mohammed First University, Oujda, Morocco
Dr. El Melhaoui Ouafae	Mohammed First University, Oujda, Morocco
Dr. Anouar Es-Salah	High School of Technology, Nador, Morocco
Dr. Fatima Ezzahra Arhouni	Chouaib Doukkali University, El Jadida, Morocco
Dr. El Mehdi Irzan	Chouaib Doukkali University, El Jadida, Morocco
Dr. Hasnae Saadi	Chouaib Doukkali University, El Jadida, Morocco
Dr. Ali Lamkaddem	Mohammed First University, Oujda, Morocco
Dr. El Melhaoui Ouafae	Mohammed First University, Oujda, Morocco
Dr. Fatima Ezzahra Arhouni	Chouaib Doukkali University, El Jadida, Morocco
Dr. El Mehdi Irzan	Chouaib Doukkali University, El Jadida, Morocco

## Scientific committee

Pr. Naoual Belouaggadia	ENSET mohamadia, Morocco
Pr. DIMANE FOUAD	Abdelmalek Essaâdi University, El hoceima, Morocco
Dr. Ali Lamkaddem	Mohammed First University, Oujda, Morocco
Dr. El Mostapha Chetouani	Mohammed First University, Oujda, Morocco
Dr. Hamza BAGAR	Chouaib Doukkali University, El Jadida, Morocco
Dr. Hicham El Achouby	Chouaib Doukkali University, El Jadida, Morocco
Dr. B. Belhamdi	Abdelmalek Essaadi University, Tetouan, Morocco
Dr. El Mostafa El Halba	Chouaib Doukkali University, El Jadida, Morocco
Pr. A. Gagliano	Università de Catane, Italy
Pr. Aarfane Abdellatif	Chouaib Doukkali University, El Jadida, Morocco
Pr. Abdekarim Oukouiss	Mohammed First University, Oujda, Morocco
Pr. Abdelatif Khamlichi	ENSA Tetouan, Morocco
Pr. Abdelhai Rahmani	University of Moulay Ismail, Meknes, Morocco
Pr. Abdelhalim El Basset	Sidi Mohamed Ben Abdellah University, Fes, Morocco
Pr. Abdelkader Doudou	Faculté Pluridisciplinaire de Nador, UMP, Oujda, Morocco
Pr. Abdellah El Youssfi	FST Alhoceima, Morocco
Pr. Abdellatif Obbadi	Chouaib Doukkali University, El Jadida, Morocco
Pr. Abdelouahhab JABRI	Sidi Mohamed Ben Abdellah University, Fes, Morocco
Pr. Abdelqader El Guerraf	Hassan I University, Settat, Morocco
Pr. Abderahman Abbassi	Sultan Moulay Slimane University, Beni Mellal
Pr. Adil BROURI	Moulay Ismail University, Meknes, Morocco
Pr. Ahmed Faize	Mohammed First University, Oujda, Morocco
Pr. Ahmed Khouya	Abdelmalek Essaâdi University, Tanger, Maroc
Pr. Ahmed Mousrij	FST Settat, Morocco
Pr. Aissa Kerkour El Miad	Mohammed First University, Ouejda, Morocco
Pr. Alami Nabil	Mohammed First University, Oujda, Morocco
Pr. Ali Kihel	Mohammed First University, Oujda, Morocco
Pr. Amal Saoud	ERA , Marrakech, Morocco
Pr. Amer Lafhal	University Chouaib Doukkali, EL Jadida, Morocco
Pr. Amine ALAOUI BELGHITI	Chouaib Doukkali University, El Jadida, Morocco
Pr. Amine Khalil	Argonne National Laboratory, Lemont, USA
Pr. Amine TILIOUA	Moulay Ismail University of Meknes, Morocco
Pr. Amrane Oukaour	Université de Caen Normandie
Pr. Asmaa Zugari	Abdelmalek Essaadi University, Tetouan, Morocco
Pr. Atef Mazioud	IUT Lieusaint, Paris
Pr. Atif IQBAL	Department of Electrical Engineering, Qatar University Doha, Qatar
Pr. Aziz MAZIRI	ENSEM, Casablanca, Morocco
Pr. Bachir El Kihel	ENSA, Oujda, Morocco
Pr. Bakkay Hajji	Mohammed First University, Oujda, Morocco
Pr. Brahim Fakrach	University of Moulay Ismail, Meknes, Morocco
Pr. Chakib Taybi	Mohammed First University, Oujda, Morocco
Pr. Chouaib Ennawaoui	Chouaib Doukkali University, El Jadida, Morocco
Pr. Daniel Tudor Cotfas	Transylvania University of Braşov Romania
Pr. David Lara-alabazares	Instituto Tecnológico Superior de Misanfla, Mexique



Pr. Daya Abdelmajid	Moulay Ismail University of Meknes, Morocco
Pr. Elhadi Baghaz	Chouaib Doukkali University, El Jadida, Morocco
Pr. Fatima Chanaa	ENSAM Meknes, Morocco
Pr. Fatima Lakrami	Chouaib Doukkali University, El Jadida, Morocco
Pr. Fouad El Otmani	Mohammed First University, Oujda, Morocco
Pr. G. M. Tina	University of Catania, Italy
Pr. Gabe Gabrielle	NASA, USA
Pr. Ghanim Rajae	Moulay Ismail University of Meknes, Morocco
Pr. H. Abouobaida	ENSA El Jadida, Morocco
Pr. Hakimi Abdelhadi	Sidi Mohamed Ben Abdellah University, Fes, Morocco
Pr. Hassan Zahboune	Mohammed First University, Oujda, Morocco
Pr. Hicham Bouali	Mohammed First University, Oujda, Morocco
Pr. Hicham Labrim	Ibn Tofail University, Kenitra, Morocco
Pr. Houcine Chafouk	Mohammed First University, Oujda, Morocco
Pr. Ismael Driouach	ENSA Al Hoceima, Morocco
Pr. Jalal Salah Eddine	Hassan II University, Casablanca, Morocco
Pr. Jayer Mohammed	Mohammed First University, Oujda, Morocco
Pr. Kamal Essifi	Chouaib Doukkali University, El Jadida, Morocco
Pr. Kaoutar Hafidi	Argonne National Laboratory, Lemont, USA
Pr. Kaoutar Lamrini Ouahabi	Mohammed First University, Oujda, Morocco
Pr. Khalid Amechnoue	Abdelmalek Essaâdi University, Tanger, Maroc
Pr. Khalid El Khadiri	Chouaib Doukkali University, El Jadida, Morocco
Pr. Khalid Nouneh Khalid	Ibn Tofail University, Kenitra, Morocco
Pr. Khalil AMINE	Distinguished Fellow, Argonne National Laboratory USA
Pr. Lamiaa El Menzhi	Abdelmalek Essaadi University, Tetouan, Morocco
Pr. Larbi Karkab	Ibn Tofail University, Kenitra, Morocco
Pr. Lounès Chelghoum	IUT Lieusaint, Paris
Pr. Mohamed Amine Abdous	Mines Mines ParisTech, France
Pr. Mohamed Atounti	Mohammed First University, Oujda, Morocco
Pr. Mohamed Belkheiri	Université Amar Telidji de Laghouat, Algeria
Pr. Mohamed Bellouki	Mohammed First University, Oujda, Morocco
Pr. Mohamed El Bojaddaini	Mohammed First University, Oujda, Morocco
Pr. Mohamed El Bouabdelati	Mohammed First University, Oujda, Morocco
Pr. Mohamed El Fissaoui	Mohammed First University, Oujda, Morocco
Pr. Mohamed El Haim	ENSA Al Hoceima, Morocco
Pr. Mohamed Elhafyani Talbi	Mohammed First University, Oujda, Morocco
Pr. Mohamed ESSAIDI	Founding President of the IEEE Morocco Section Morocco
Pr. Mohamed Hanine	Chouaib Doukkali University, El Jadida, Morocco
Pr. Mohamed Barbachi	ENSA, Agadir, Morocco
Pr. Mohamed Bezzazi	FST Tanger, Morocco
Pr. Mohammed Essaidi	ENSIAS, Rabat, Morocco
Pr. Mohammed Lahlou	Chouaib Doukkali University, El Jadida, Morocco
Pr. Mohammed Maazouzi	ENSEM Casablanca, Morocco
Pr. Mohssin Aoutoul	Chouaib Doukkali University, El Jadida, Morocco
Pr. Mouhib Nadia	ISEM, Casablanca, Morocco
Pr. Mouncef Filali Bouami	Mohammed First University, Oujda, Morocco

Pr. Mourad Kaouini	Mohammed First University, Oujda, Morocco
Pr. Mousa Marzband	King Abdulaziz University, Jeddah, Saudi Arabia
Pr. Moussa Admi	Mohammed First University, Oujda, Morocco
Pr. Mustapha Lamine	Hassan II University, Casablanca, Morocco
Pr. Nadia El Abass	Mohammed First University, Oujda, Morocco
Pr. Nasiruddin Muhammad	Universiti Sains, Malaysia
Pr. Nasser Abdelkader	Mohammed First University, Oujda, Morocco
Pr. Noureddine El Moussaoui	Hassan II University, Casablanca, Morocco
Pr. Omar Bajou	Sultan Moulay Slimane University, Beni Melal, Morocco
Pr. Ouidad Labouidya	Chouaib Doukkali University, El Jadida, Morocco
Pr. PetruTudor Cotfas	Transylvania University of Braşov Romania
Pr. Pierre Dehombreux	University of Mons, Belgium
Pr. R. Herbazi	EMSI, Tanger, Morocco
Pr. Rachid Bendaoud	ESEF Berrechid, Morocco
Pr. Rachid Benkaddour	Mohammed First University, Oujda, Morocco
Pr. Rachid Bennacer	Ecole Normale Supérieure, Paris, France
Pr. Redouane Mghaiouini	Ibn Tofail University, Kenitra, Morocco
Pr. Rehena Nasrin	Bangladesh University of Engineering and Technology, Bangladesh
Pr. Rochdi Majid	Mohammed First University, Oujda, Morocco
Pr. Saadouki Bouchra	Hassan II University, Casablanca
Pr. Safaa El Ouahabi	Mohammed First University, Oujda, Morocco
Pr. Said Bounouar	ENSAM Casablanca, Morocco
Pr. Said Ounasser	Mohammed First University, Oujda, Morocco
Pr. Said Bacroume	Mohammed First University, Oujda, Morocco
Pr. Sameer Al-Dahidi	German Jordanian University, Oman, Jordan
Pr. Samira Khoulgie	ENSA Tetouan, Morocco
Pr. Sara Teidj	Moulay Ismail University of Meknes, Morocco
Pr. Sara Sandabad	ISEM, Casablanca, Morocco
Pr. Smail Zouggar	Mohammed First University, Oujda, Morocco
Pr. Sofian Talbi	Mohammed First University, Oujda, Morocco
Pr. Soufian Lakrit	Mohammed First University, Oujda, Morocco
Pr. Tarik Mrabti	Abdelmalek Essaadi University, Tetouan, Morocco
Pr. Wafae Elhamdani	Mohammed First University, Oujda, Morocco
Pr. Youssra El Kihel	CESI Bordeaux, France
Pr. Zakaria Tahri	Abdelmalek Essaadi University, Tetouan, Morocco
Pr. Zouhair El Jouad	Chouaib Doukkali University, El Jadida, Morocco
Pr. Issam Hanafi	Abdelmalek Essaâdi University, El Hoceima, Morocco
Pr. Sara Naamane	Abdelmalek Essaâdi University, El Hoceima, Morocco
Pr. Ahmed Toukmati	Abdelmalek Essaâdi University, El Hoceima, Morocco
Pr. Anisse Moutaouakil	Mohammed First University, Oujda, Morocco
Pr. Abdellah LAAZIZI	Moulay Ismail University of Meknes, Morocco
Pr. Manish Kumar Singla	Chitkara University, India
Pr. Abdelhamid TOUACHE	Sidi Mohamed Ben Abdellah University, Fes, Morocco
Pr. Abdellah OUSEGUI	Moulay Ismail University, Meknes, Morocco
Pr. Achraf Wahid	Abdelmalek Essaâdi University, El Hoceima, Morocco

Pr. El Ghaouti CHAHID	Chouaib Doukkali University, El Jadida, Morocco
Pr. En-Naji Abderrazak	Moulay Ismaïl University, Errachidia, Morocco
Pr. Fatima Ezzahrae M'hamdi Alaoui	Abdelmalek Essaâdi University, Tetouan, Maroc
Pr. Hamid Nasrellah	Chouaib Doukkali University, El Jadida, Morocco
Pr. Hanaa Ouaomar	Sultan Moulay Slimane University , Beni Mellal, Morocco
Pr. Hassan Ahmoum	Faculté de Médecine et de Pharmacie d'Agadir
Pr. Kawtar HAFIDI	Argonne National Laboratory, Physics division USA
Pr. Kerkour-El Miad Abdelhamid	Mohammed First University, Oujda, Morocco
Pr. Khalid Janati	Sidi Mohamed Ben Abdellah University, Fes, Morocco
Pr. KHATIB Hamza	Hassan II University, Casablanca, Morocco
Pr. Lmokhtar Ikharrazne	Hassan II University, Casablanca, Morocco
Pr. Sheraz Aslam	Cyprus University of Technology Limassol, Cyprus
Pr. Tariq Kamal	University of Vaasa, Vaasa, Finland
Pr. Wahid Achraf	Abdelmalek Essaâdi University, El hoceima, Morocco
Pr. Ali Azdimousa	Dean of Multidisciplinary Faculty, Nador, Morocco
Pr. Mohamed Louzazni	ENSAJ, El Jadida, Morocco
Pr. Saïd Dlimi	Chouaib Doukkali University, El Jadida, Morocco
Pr. Wiam Ayrir	Ibn Tofail University, Kenitra, Maroc





---

**Invited Speakers**

---



## Mr. Gabe Gabrielle

Former NASA Engineer, USA

### To Infinity and Beyond

#### Summary

Gabe will give a motivational presentation to encourage students to adopt three key principles: always do your best, enjoy everything you do, and believe in yourself. Gabrielle's mission is to instill hope and positivity in young minds, showing them that a fulfilling life is attainable through hard work and passion.

---

*Gabe Gabrielle has dedicated approximately 17 years to NASA as an Engineering Programmer at the Kennedy Space Center (KSC), where he has played a crucial role in maintaining and improving the infrastructure, including roads, bridges, mechanical systems, and environmental conditions. His responsibilities include identifying problems, proposing solutions, calculating costs, and prioritizing funding for necessary repairs. Gabrielle is also an active member of NASA's Disability Awareness and Action Working Group, where he works to enhance the work environment for personnel with disabilities, and has served on NASA's Speakers Bureau for 11 years, sharing his passion for space exploration with young audiences.*

*His experiences at KSC have provided him with unparalleled access to significant facilities such as the Vehicle Assembly Building and Launch Complexes. Gabrielle recalls the thrill of witnessing shuttle launches firsthand, describing the powerful sensations of the earth shaking and the shuttle ascending into the sky. These experiences have fueled his desire to inspire children about careers in Science, Technology, Engineering, Arts, and Mathematics (STEAM), emphasizing the importance of believing in oneself and pursuing dreams.*

---



## Pr. Mohamed ESSAIDI

Founding President of the IEEE Morocco Section

### Smart Cities, Smarter Futures: Accelerating UN SDGs Through Innovation

Mohamed ESSAIDI

#### Abstract

As urbanization continues to shape the global landscape, smart cities are emerging as pivotal hubs for sustainable development and innovation. This keynote explores how smart city initiatives can act as powerful accelerators for achieving the United Nations Sustainable Development Goals (SDGs). By integrating cutting-edge technologies, data-driven solutions, and citizen-centric approaches, smart cities have the potential to revolutionize urban living, address pressing global challenges, and promote inclusive, equitable, and resilient communities. Join us to discover transformative strategies and success stories that demonstrate how smart cities are shaping smarter futures for all.

---

*Mohamed ESSAIDI is the founder and current president of the IEEE Moroccan Section since November 2004. He founded the Mediterranean Microwave Symposium (MMS) in 2000 and the Information and Communication Technologies International Symposium (ICTIS) in 2005. He co-directed the NATO Advanced Research Workshop on Information Security Assurance in Tetouan in 2005. Additionally, he chairs the Scientific Committees of several symposia and conferences, and referees for multiple journals including IEEE Transactions on Microwave Theory and Techniques.*

---





## Pr. Daniel TUDOR COTFAS

Transylvania University of Braşov, Romania

### Advancements and challenges in hybrid systems for renewable energy

Daniel TUDOR COTFAS

Transylvania University of Braşov, Romania

#### Abstract

Due to the variability of solar energy, efficient solutions must be found that have an almost continuous supply of the systems. One of the efficient methods in this case is the use of hybrid systems, that is, the use of two or more methods. Hybrid systems can use solar energy and wind energy, solar energy, wind and geothermal energy or biomass, etc., or can transform solar energy into electrical and thermal energy. My presentation will focus on hybrid systems in the last category, namely systems consisting of photovoltaic panels and thermoelectric generators or both and solar collectors. These systems are analyzed in different structures, in natural light and concentrated light.

These systems will be analyzed and discussed in terms of advantages and disadvantages, limitations and challenges. Also, different applications will be discussed and analyzed.

---

*Daniel Tudor Cotfas is Professor in Electronics and Computers Department, at the Transylvania University of Brasov, Romania. His research interest is in the characterization of the hybrid PV components, virtual instrumentation, and remote systems control. During his career he received several awards - Gold medal at invention salon Euroinvent 2015; National Instruments Graphical System Design Achievement Awards 2013, USA, Austin: Education Winner, NI Community's Choice; Editor's Choice Award; Romania National Instruments NIDays Contest 2012 Romania, Bucharest. Prof. Dr. Cotfas published more than 65 papers in ISI journals or ISI conferences and over 50 papers in proceedings of international and national conferences and has reviewed more than 100 papers for ISI and BDI journals.*

---



## Pr. Petru Adrian Cotfas

Transilvania University of Brasov, Romania

### Characterization of solar thermoelectric generator based on RIO hardware

Petru A. COTFAS, Daniel T. COTFAS

Transilvania University of Brasov, Electrical Engineering and Computer Science Faculty, 500036 Brasov, Romania

#### Abstract

Renewable energy sources have become a solution for the increasing energy demand of humankind. Different renewable sources are used today like solar, wind, biomass, or ocean waves. The solar irradiance can be used based on photovoltaic or thermic processes. The latter can be used for thermal energy generation or electrical energy generation. One solution for electrical energy generation based on the thermic process is to use the thermoelectrical generators which are based on the Seebeck effect. To use these generators, it is necessary to understand how they work and how they are characterized. The focus of this paper is to develop a modular and reconfigurable system for thermoelectric generator characterization and study. The device is based on the RElab board and NI myRIO device. The system allows the study of the behavior of the thermoelectric generators in laboratory conditions, but also in natural conditions like solar thermoelectric generators. In the laboratory conditions, the temperature gradients of the two sides of the generator can reach more than 500C. The paper also presents the study of the solar thermoelectric generator with and without graphite sheet as solar irradiance absorber which increases its efficiency three times. Also, steady state and transient conditions are studied and presented.

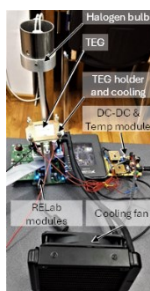

#### References

1. O. H. Ando Jr., C. L. Izidoro, J. M. Gomes, J. H. Correia, J. P. Carmo, and L. Schaeffer, Acquisition and Monitoring System for TEG Characterization, International Journal of Distributed Sensor Networks, Vol. 2015, 2015
2. P.A.Cotfas, D.T.Cotfas, Design and implementation of RElab system to study the solar and wind energy, Measurement, Volume 93, November 2016, Pages 94-101

#### The STEG testig device in laboratory conditions

**Petru A. Cotfas** is a full professor at the Electronics and Computers Department, Faculty of Electrical Engineering and Computers Science, Transilvania University of Brasov, Romania. He received his BSc degrees in mathematics and physics and also in computer science in 1997 and 2001, respectively, and his MSc degree in mathematics and computer science at Transilvania University of Brasov in 1998. In 2007, he obtained a PhD in material science engineering at Transilvania University of Brasov. His research interests include photovoltaics and hybrid systems characterization and testing, virtual instrumentation, data acquisition, graphical programming, and remote engineering. He is a member of the Institute of Electrical and Electronics Engineers, the International Association of Online Engineering and the Romanian Physical Society.

The background of the entire page is a repeating geometric pattern of interlocking stars and polygons in a light gray color. The pattern is centered and covers the entire area.

---



---

# Oral Communications



---



---

**Topic 1: *Advancements in Biomaterials, Environmental Engineering, and Renewable Energy Technologies***

---

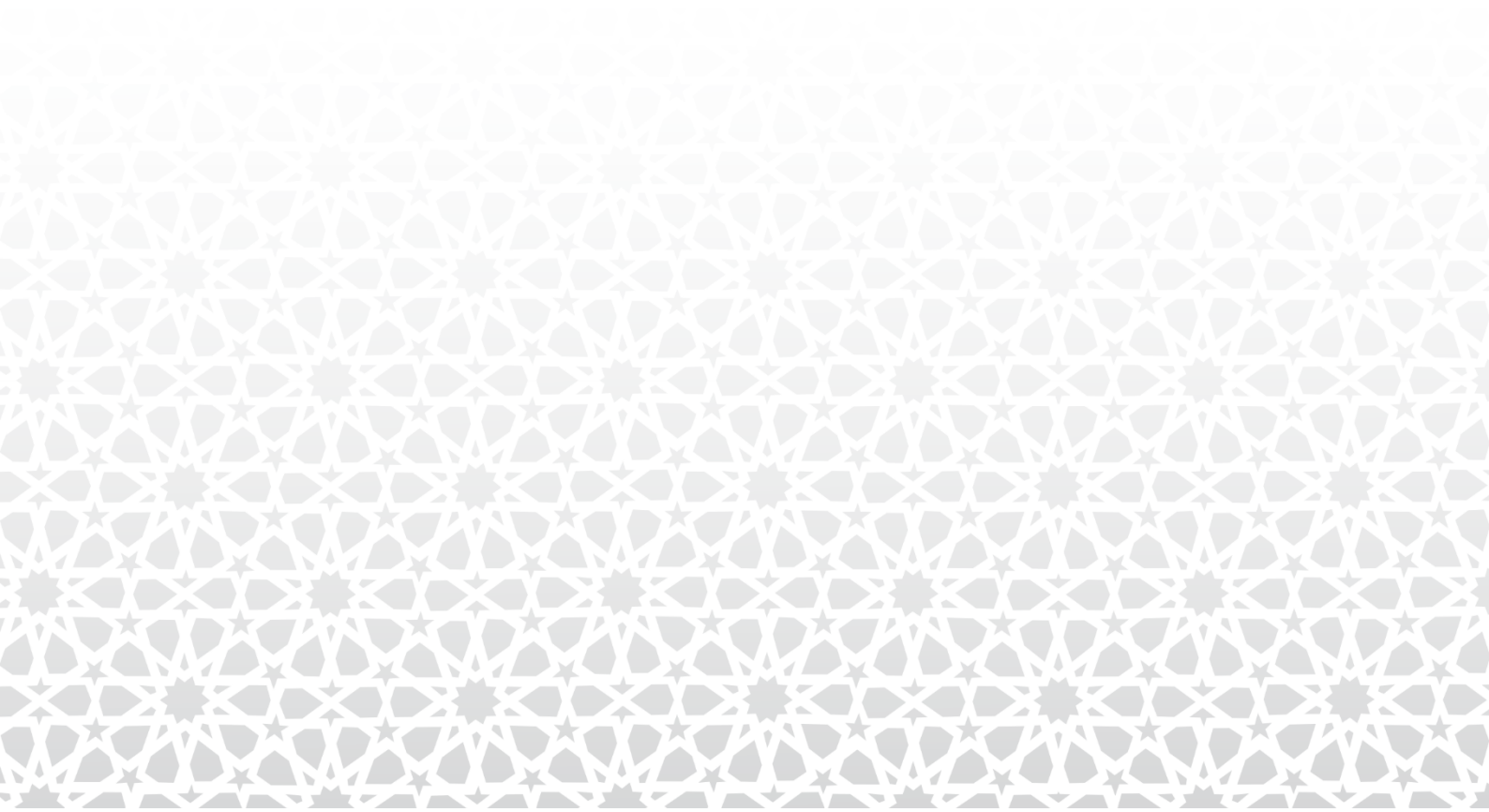

ID : 7

## Metal-organic frameworks for enhanced hydrogen production: A pathway to sustainable energy

Abdelqader El Guerraf<sup>1,2</sup>, Kamal Essifi<sup>3</sup>, Meriyem Mouloudi<sup>1</sup>, Ghulam Abbas<sup>4</sup>, Mohammed Bazzaoui<sup>5</sup> and El Arbi Bazzaoui<sup>6</sup>

<sup>1</sup>Laboratory of Applied Chemistry and Environment, Faculty of Sciences and Techniques, Hassan First University, 26002 Settat, Morocco

<sup>2</sup>International Society of Engineering Science and Technology, United Kingdom

<sup>3</sup>Coordination and Analytical Chemistry Laboratory, Faculty of Sciences, University of Chouaib Doukkali, El Jadida, Morocco

<sup>4</sup>Department of Chemical Engineering and Waterloo Institute of Nanotechnology, University of Waterloo, Ontario N2L 3G1, Canada

<sup>5</sup>Materials and Environmental Laboratory, Faculty of Sciences, Ibn Zohr University, Agadir, Morocco

<sup>6</sup>Laboratory of Applied Chemistry and Environment, Faculty of Sciences, Chemistry Department, Mohammed First University, 60000 Oujda, Morocco

### Abstract

The global transition toward sustainable energy sources has sparked growing interest in hydrogen production due to its high energy density and clean combustion. Metal-organic frameworks (MOFs) have emerged as promising materials in this field owing to their tunable porosity, high surface area, and versatile chemical functionality. This presentation explores the use of MOFs for hydrogen production, focusing on their role in hydrogen storage, photocatalytic water splitting, and electrochemical hydrogen evolution. We hypothesize that the unique structural and electronic properties of MOFs can significantly enhance hydrogen production efficiency by facilitating charge transfer and gas diffusion. The synthesis of MOFs with specific metal nodes and organic linkers, tailored to optimize catalytic activity, is discussed. Experimental results demonstrate enhanced hydrogen production rates, with key findings showing improved performance under various operational conditions. We conclude that the development of MOF-based materials holds immense potential for scalable and sustainable hydrogen production, paving the way for future green energy solutions.

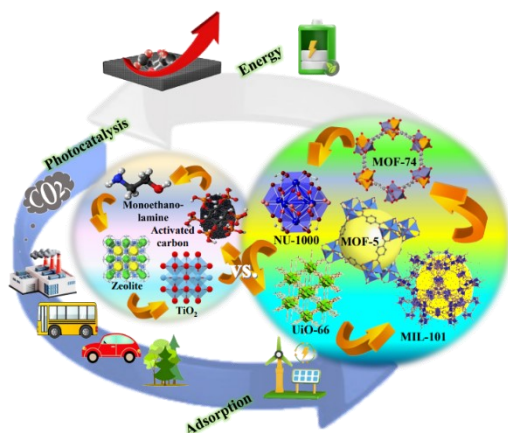

### References

1. A. El Guerraf, W. Zeng, A. Mantel, E. Benhsina, J.M. Chin, H. Shiozawa, *Advanced Electronic Materials* (2024): 2300854.
2. F. Sher, A. Hayward, A. El Guerraf, I. Ziani, H. Hrnjić, E. Boškailo, B. Wang, A. Chupin, M. R. Nemţanu, *Journal of Materials Chemistry A* (2024).
3. A. El Guerraf, S. Ben Jadi, I. Ziani, M. Dalli, F. Sher, M. Bazzaoui, E.A. Bazzaoui, *Industrial & Engineering Chemistry Research* 62.11 (2022): 4540-4553.
4. A. El Guerraf, S. Ben Jadi, Z. Aouzal, M. Bouabdallaoui, N.K. Bakirhan, S.A. Ozkan, M. Bazzaoui, E.A. Bazzaoui, *Journal of Applied Electrochemistry* 52.9 (2022): 1383.
5. A. El Guerraf, M. Bouabdallaoui, Z. Aouzal, S. Ben Jadi, NK Bakirhan, M. Bazzaoui, SA Ozkan, EA Bazzaoui



**Abdelqader El Guerraf**

Passionate research scientist with experience in physical chemistry and electrochemistry. Currently a Senior Lecturer at University Hassan I, with a strong focus on electrosynthesis, electroanalytical techniques, nanomaterials, polymers, metal organic frameworks and protective coatings. Extensive expertise in developing advanced materials and applying cutting-edge spectroscopic and microscopic characterization methods. Dedicated to innovative research and teaching in the fields of material science and electrochemistry.

**Email:** [abdelqader.elguerraf@uhp.ac.ma](mailto:abdelqader.elguerraf@uhp.ac.ma)

## Design of Phosphate-based Biocomposites for Local Delivery of Bioactive Molecules in Bony Tissue

Houda Moukadiri<sup>1</sup>, Hassan Noukrati<sup>1</sup>, Hicham Ben Youcef<sup>2</sup>, Allal Barroug<sup>1,3</sup>

<sup>1</sup>Mohammed VI Polytechnic University, Institute of Biological & Paramedical Sciences, Faculty of Medical Sciences, Benguerir, Morocco

<sup>2</sup>Mohammed VI Polytechnic University, High Throughput Multidisciplinary Research Laboratory, Benguerir, Morocco

<sup>3</sup>Cadi Ayyad University, Faculty of Sciences Semailia, SCIMATOP-PIB, Marrakesh, Morocco

### Abstract

Calcium phosphate (CaP) biomaterials are gaining increasing interest in orthopedics, thanks to their wide range of properties. The functionalization of CaPs is a promising strategy that enables the improvement of their properties and/or the impartation of new functionalities such as mechanical support, and therapeutic activity [1]. Casein hydrolysate (CHL) has garnered attention for its potential benefits in supporting bone health [2]. Thus, the association of CaP with CHL holds promise for developing new composites for application in targeted treatment of bone-associated pathologies. The adsorption approach is a key step in the association of CaP materials with CHL molecules. It allows a good understanding of the mechanisms, and the driving forces involved in both retention and release processes, which is crucial for the determination of the biocomposite's performance in vitro and in vivo [3]. This study aims to elucidate the adsorption and release behaviors of CHL onto CaP compounds, for potential application in drug delivery in orthopedics.

In this context, three CaP compounds with various physicochemical properties were investigated for their adsorption and release behaviors for casein hydrolysate. The results showed a rapid uptake of CHL molecules on CaP surfaces and the retention processes are well described by the Langmuir model. The adsorption performance is greatly affected by CaP physicochemical characteristics including microstructure, surface charge, and crystallinity. Furthermore, the composition of the adsorption medium (ionic strength, pH, and ion content) has a pronounced influence on the adsorption capacity. On the other hand, the release of CHL from the CaPs was fast and showed an ultimate dependence on the CaP properties and medium composition. Finally, the retention process of CHL is primarily governed by electrostatic interactions. The obtained findings are encouraging and hold promise for further research on CHL-loaded CaP for application in the targeted treatment of bone pathologies.

### References

1. A. Bigi and E. Boanini, "Functionalized biomimetic calcium phosphates for bone tissue repair," *J. Appl. Biomater. Funct. Mater.*, vol. 15, no. 4, pp. 313–325, 2017, doi: 10.5301/jabfm.5000367.
2. K. Sarabandi, A. Sadeghi Mahoonak, H. Hamishekar, M. Ghorbani, and S. M. Jafari, "Microencapsulation of casein hydrolysates: Physicochemical, antioxidant and microstructure properties," *J. Food Eng.*, vol. 237, no. March, pp. 86–95, 2018, doi: 10.1016/j.jfoodeng.2018.05.036.
3. K. Wang, C. Zhou, Y. Hong, and X. Zhang, "A review of protein adsorption on bioceramics," *Interface Focus*, vol. 2, no. 3, pp. 259–277, 2012, doi: 10.1098/rsfs.2012.0012.



*Houda Moukadiri is currently a 4<sup>th</sup>-year Ph.D. student in the Biomedical Materials Engineering Lab at the Faculty of Medical Sciences, UM6P Benguerir. Her research work focuses on the development of Phosphate-based biocomposites for targeted treatment of bone infections. This involves the study and the optimization of the interactions and the driving forces responsible for the antibiotic loading and release processes, to obtain a sustained and controlled delivery of the cargo for efficient local therapy of bone-associated infections.*

*Email : houda.moukadiri@um6p.ma*

## Secondary fragmentation of carbon ion beams in a water phantom: Monte Carlo simulation with TOPAS

Ikram Habib Allah <sup>1</sup>, Ayoub Marhou <sup>2</sup>, Mohammed Hamal, Nouredine Chafi

<sup>1</sup> Laboratory of Physics of Matter and Radiations in Faculty of Sciences, Mohammed First University, Oujda, Morocco

<sup>2</sup> Laboratory of Physics of Matter and Radiations in Faculty of Sciences, Mohammed First University, Oujda, Morocco

### Abstract

Carbon-12 ions are among the heaviest ions used in hadron therapy. Carbon particles, which are 12 times heavier than protons, have properties that make them particularly suitable for cancer treatment due to their superior physical dose distribution and Relative Biological Effectiveness (RBE). Unlike the proton beam, carbon ions produce secondary particles that deposit an additional dose that needs to be characterised.

In this study, we focus on carbon-12 fragments produced by a 270 MeV/u primary carbon ion beam, simulated using Monte Carlo methods via TOPAS (Tool for Particle Simulation). After the carbon-12 ions interact with a water phantom, the secondary particles produced at the output end of the Bragg peak like (neutrons) and six types of light charged particles: hydrogen (H), helium (He), boron (B), beryllium (Be), carbon-11 (<sup>11</sup>C), and lithium (Li) form a mixed field of particles with different energies accompanied by an additional dose.

### References

1. Ying, C. K., Bolst, D., Tran, L. T., Guatelli, S., Rosenfeld, A. B., & Kamil, W. A. (2017, May). Contributions of secondary fragmentation by carbon ion beams in water phantom: Monte Carlo simulation. In *Journal of Physics: Conference Series* (Vol. 851, No. 1, p. 012033). IOP Publishing.
2. Johnson, D., Chen, Y., & Ahmad, S. (2015). Dose and linear energy transfer distributions of primary and secondary particles in carbon ion radiation therapy: A Monte Carlo simulation study in water. *Journal of medical physics*, 40(4), 214-219.
3. Hamad, M. K. (2021). Bragg-curve simulation of carbon-ion beams for particle-therapy applications: A study with the GEANT4 toolkit. *Nuclear Engineering and Technology*, 53(8), 2767-2773.
4. Haettner, E., Iwase, H., Krämer, M., Kraft, G., & Schardt, D. (2013). Experimental study of nuclear fragmentation of 200 and 400 MeV/u <sup>12</sup>C ions in water for applications in particle therapy. *Physics in medicine & biology*, 58(23), 8265.



*Ikram Habib Allah has expertise in medical physics, specializing in the application of physics principles to medicine and healthcare. She is currently pursuing a PhD at a leading institution, focusing on innovative imaging techniques and radiation therapy optimization.*

**Email:** ikram.habiballah.d23@ump.ac.ma



## Low Gain Avalanche Detector for monitoring flash radiotherapy beam: A TCAD & Monte Carlo Simulation study

Fatima Zahra Rimchi, Abdelilah Moussa

Faculty of Sciences, Mohamed I<sup>st</sup> University, Oujda, Morocco

### Abstract

The FLASH radiotherapy is an innovative cancer treatment delivering ultra-high dose rates in a very short time, often less than a second. This technique is gaining attention due its ability to minimize damage to healthy tissues and shortens treatment time <sup>1</sup>. This emerging technique has the potential to revolutionize radiotherapy by improving both patient outcomes and treatment efficiency. However, the high-intensity, rapid dose delivery of FLASH radiotherapy introduces significant challenges in dosimetry. Traditional dosimeters cannot accurately measure doses in real time at these ultra-high dose rates, limiting the ability to ensure precise and safe treatment delivery. The lack of reliable dosimetry solutions is a critical issue that must be addressed before FLASH radiotherapy can be fully implemented in clinical settings.

To overcome these challenges, we propose the use of Low Gain Avalanche Detector (LGAD) <sup>2</sup> as a novel solution for dose monitoring in FLASH radiotherapy. LGADs are semiconductor detectors specifically designed to provide a gain higher than six, achieved through the process of impact ionization. This internal gain enhances the sensitivity and response of the detector, making it ideal for capturing the rapid and intense dose rates characteristic of FLASH therapy.

In this work, we report a precise simulation of the LGADs Detector and provide a detailed analysis of the detector's behavior, offering insight into its potential performance and laying the groundwork for future optimization. This study represents a crucial step towards developing reliable dosimetry systems for the safe and effective implementation of FLASH radiotherapy.

**Keywords:** FLASH radiotherapy, ultra-high dose rates, dosimetry, Low Gain Avalanche Detector (LGAD), TCAD simulation.

### References

1. Rimchi, F. Z., Moussa, A., El Hamli, A., & Tayalati, Y. (2024, April). Monte Carlo Simulation of a Modified Elekta Precise Linear Accelerator Used for Flash Radiotherapy Using TOPAS (TOol for PArticle Simulation). In International Conference on Smart Medical, IoT & Artificial Intelligence (pp. 215-223). Cham: Springer Nature Switzerland.
2. Pellegrini, G., Fernández-Martínez, P., Baselga, M., Fleta, C., Flores, D., Greco, V., ... & Ullan, M. (2014). Technology developments and first measurements of Low Gain Avalanche Detectors (LGAD) for high energy physics applications. Nuclear Instruments and Methods in Physics Research Section A: Accelerators, Spectrometers, Detectors and Associated Equipment, 765, 12-16.



## Advances in controlled-release fertilizer encapsulated by Alginate-Biochar-Based Biomaterials

Abdelghani LAAMAOUI <sup>1,2</sup>, Kamal ESSIFI <sup>2</sup>, Hanan EL ALAOUI-BELGHITI <sup>1</sup>

<sup>1</sup> Laboratory of Physical-Chemistry of Materials Chemistry Department, Faculty of Science, Chouaib Doukkali University, El Jadida, Morocco.

<sup>2</sup> Coordination and Analytical Chemistry Laboratory, Faculty of Sciences, University of Chouaib Doukkali, El Jadida, Morocco.

### Abstract

Alginate, a biodegradable biopolymer, combined with biochar, a carbon-rich material derived from biomass, offers an innovative approach to developing controlled-release fertilizers (CRFs). This combination harnesses the nutrient retention and water-holding capacity of biochar alongside the encapsulation and biodegradability properties of alginate, enabling efficient nutrient delivery, reducing nutrient loss through leaching, and improving soil quality.

This review delves into the progress and mechanisms underpinning alginate-biochar-based biomaterials for CRFs, charting their evolution from early formulations to recent advancements. By highlighting their role in enhancing agricultural efficiency and mitigating environmental challenges, this work underscores their potential as a sustainable alternative to conventional fertilizers.

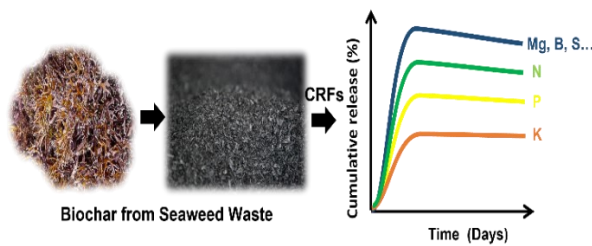

**Shema. Controlled Release Fertilizers Using Alginate-Biochar**

### References

1. Essifi, K., Brahmi, M., Ed-Daoui, A., Boussetta, A., Benelmostafa, M. H., Dahmani, M., Salhi, S., Moubarik, A., El Bachiri, A. & Tahani, A. (2023). International Journal of Biological Macromolecules, 242, 125011..
2. Brahmi, M., Essifi, K., Bakirhan, N. K., El Bachiri, A., Ouldriane, S. D., & Tahani, A. (2023). Journal of Molecular Liquids, 387, 122635.
3. Essifi, K., Hammani, A., Berraouan, D., El Bachiri, A., Fauconnier, M. L., & Tahani, A. (2022). Materials Chemistry and Physics, 277, 125569



*I have solid expertise in formulating various types of liquid and solid fertilizers. My experience includes developing advanced encapsulation techniques and controlled-release systems using biomaterials or biocomposites to regulate the release of nutrients. These approaches aim to enhance fertilizer efficiency while minimizing their environmental impact. This expertise also extends to designing innovative solutions to improve the effectiveness and sustainability of agricultural practices.*

**Email:** laamaouiabd@gmail.com

## Biopolymer-Integrated Amorphous Calcium Phosphate for Bone Grafts: An In Situ Functionalization Approach

Hamza Elbaza<sup>1</sup>, Hanaa Mabrouma<sup>1</sup>, Hicham Ben Youcef<sup>2</sup>, Allal Barroug<sup>1,3</sup>, Hassan Noukrati<sup>1</sup>

<sup>1</sup> Institute of Biological & Paramedical Sciences, Faculty of Medical Sciences, Mohammed VI Polytechnic University, Benguerir, Morocco

<sup>2</sup> High Throughput Multidisciplinary Research Laboratory, Mohammed VI Polytechnic University, Benguerir, Morocco

<sup>3</sup> Cadi Ayyad University, Faculty of Sciences Semlalia, SCIMATOP-PIB, Marrakech, Morocco

### Abstract

Amorphous calcium phosphate (ACP) has been widely applied in biomedical fields (dentistry and orthopaedics) due to its excellent biological properties. Compared to other calcium phosphate components, ACP has been demonstrated to have better biodegradability than tricalcium phosphate, higher in vivo osteoconductivity than hydroxyapatite, and good bioactivity without any cytotoxicity [1]. Nevertheless, the limited lifespan [2] and the fragile mechanical properties of ACP-based materials [3] represent the primary disadvantages that prevent their application as implants for hard tissues. In this light, the current study focuses on the in situ functionalization of ACP powders using biopolymers as well as the manufacturing of three-dimensional composites derived from the resulting composite powders.

The effect of different biopolymers on the chemical composition, the lifetime of the amorphous phase, and the mechanical strength of the prepared three-dimensional materials was evaluated. The XRD and FTIR analyses revealed that the in situ synthesized composite powders are amorphous and similar to the ACP-free polymer. In order to estimate the amorphous phase lifetime and to follow up the evolution of the amorphous components, the chemical composition of the prepared composite powders was monitored over time and compared to ACP-free polymers. ACP-free polymer exhibited a fast conversion into the apatite phase. However, the in situ functionalization led to an extended lifetime of the amorphous phase, enhancing its stability. The three-dimensional composites derived from ACP polymers showed a compressive strength similar to that of spongy bone. The in vitro bioactivity and biodegradability of the prepared composites were evaluated and confirmed using a simulated body fluid solution.

The findings indicated that the developed powders and their composites could be used as a potential biomaterial for bone and dental engineering applications.

### References

1. J. Zhao, Y. Liu, W. Sun and H. Zhang, Chemistry Central Journal, 5 (40), (2011), p. 17056-17075.
2. J. Yan, H. Yang, T. Luo, F. Hua and H. Hu, Frontiers in bioengineering and biotechnology, 10 (30), (2022) p. 1233-1243.
3. M. Furko, K. Balazsi, C. Balazsi., Coatings, 13(2), (2023) p. 360-390.



**Hamza ELBAZA** holds a master's degree in Materials Science and Engineering from Cadi Ayyad University, obtained in 2019. Currently, he is a Ph.D. candidate at the faculty of medical sciences of Mohammed 6 polytechnic university (UM6P), specializing in Biomaterial Sciences and Engineering. His thesis work focuses on the development of advanced calcium-phosphate biomaterials for bone regeneration.

**Email:** hamza.elbaza@um6p.ma

ID : 41

## Detailed Thermal Characterization and Experimental Verification of 2D Temperature Distributions in Photovoltaic Modules

A. Kadyri<sup>1</sup>, EM. Assaid<sup>1</sup>, K. Kandoussi<sup>2</sup>, O. Souhar<sup>1</sup>

<sup>1</sup> Chouaib Doukkali university, Faculty of Sciences, El Jadida, Morocco.

<sup>2</sup> National School of Applied Sciences, El Jadida, Morocco.

### Abstract

In this paper, we use fully explicit finite difference methods to model the thermal dynamics in the layered structure of a photovoltaic (PV) module. By solving the conductive heat transfer equation, we analyze temperature variations and their effects on module efficiency. The model examines key components, from the glass cover to the semiconductor layers and the Tedlar backsheet, each influencing the module's thermal behavior. Boundary conditions account for combined convection and radiation. We validate the model by comparing simulated temperature profiles at the Tedlar layer with real-world measurements under different irradiance conditions, showing a strong correlation through statistical indices like NMSE, MRSE, and COR.

### References

1. Kadyri A., Kandoussi K., Souhar O., An approach on mathematical modeling of PV module with sensitivity analysis: a case study. *Journal of Computational Electronics*, (2022), 1365-1372.
2. Lee Y., Tay A.A.O., Finite element thermal analysis of a solar photovoltaic module, *Energy Procedia* 15 (2012), 413–420.
3. Souhar, O. and Prud'homme, C.: "Numerical analysis method of heat transfer in an electronic component using sensitivity analysis," *Journal of Computational Electronics*, vol. 13, pp.1042- 1053 (2014).



*A. Kadyri has expertise in Mathematical Modeling and Informatic Application.*

*Email: kadyri.a@ucd.ac.ma*



## Reliability Analysis of Unstabilized Rammed Earth: The effect of Lateral Wind Pressure

Salhi Chaymae<sup>1</sup>, El Mkhalel Mouna <sup>2</sup>, Lamdouar Nouzha<sup>3</sup>

<sup>1</sup> PhD student in Civil Engineering and Construction structure GCC laboratory, Mohammadia School of Engineers EMI, Mohammed V University, Rabat, Morocco

<sup>2</sup> Doctor at Mohammadia School of Engineers, Mohammed V University, Morocco

<sup>3</sup> Professor in the Department of Civil Engineering, Mohammadia School of Engineers, Mohammed V University, Morocco

### Abstract

Rammed earth is an ancient construction technique, historically used in various regions around the world, including Morocco, Australia, and France. Recently, it has experienced renewed interest due to its environmental benefits. This study focuses on the reliability analysis of unstabilized rammed earth walls, with particular attention to the effects of wind pressure, which is a critical factor in the design and construction of these walls. Wind pressure is considered in the RPCTerre 2011 (Moroccan Seismic Regulation for Earth Constructions), as well as in several studies analyzing the performance of rammed earth structures. The reliability analysis in this study is conducted using Monte Carlo Simulation. First, a limit state function is established, followed by the identification of relevant random variables and their statistical parameters. These variables include the weight of the roof, wind pressure, and the compressive strength of rammed earth walls. Deterministic variables, such as wall dimensions, are also incorporated into the analysis. The Python-based Monte Carlo simulation was performed to identify the critical values of the random variables that lead to the failure of rammed earth walls. A statistical analysis of the results is presented to provide a comprehensive understanding of the impact of wind pressure on the stability and performance of rammed earth walls. This study is significant for its original focus on the reliability of unstabilized rammed earth walls, a subject that has not been thoroughly studied. It also offers new insights into the stability of rammed earth constructions in modern contexts.

### References

1. Ávila, F., Puertas, E., & Gallego, R. (2021). Characterization of the mechanical and physical properties of unstabilized rammed earth: A review. *Construction and Building Materials*, 270, 121435. <https://doi.org/10.1016/j.conbuildmat.2020.121435>
2. Ciancio, D., & Augarde, C. (2013). Capacity of unreinforced rammed earth walls subject to lateral wind force : Elastic analysis versus ultimate strength analysis. *Materials and Structures*, 46. <https://doi.org/10.1617/s11527-012-9998-8>
3. Kianfar, E., & Toufigh, V. (2016). Reliability analysis of rammed earth structures. *Construction and Building Materials*, 127, 884-895. <https://doi.org/10.1016/j.conbuildmat.2016.10.052>
4. Munyua, M. (2021). Determining the Magnitude of Wind Loads on Structures in Kenya according to the Eurocodes. *ScienceOpen Preprints*. <https://doi.org/10.14293/S2199-1006.1.SOR-.PPBRJ1U.v3>
5. The Moroccan Seismic Regulation for Earth Constructions (RPC Terre 2011)



*I have expertise in civil engineering and I'm currently pursuing my PhD, which involves studying the mechanical properties and behavior of rammed earth using AI tools. I presented a poster on rammed earth under seismic loads at a conference and have a paper under peer review analyzing the reliability of rammed earth structures.*

**Email:** [chaymae.salhi@research.emi.ac.ma](mailto:chaymae.salhi@research.emi.ac.ma)

## Development of calcium phosphate cements as potential drug delivery systems of ciprofloxacin: Effect of additives on the functional properties, drug delivery, and antibacterial efficiency

H. Mabroum<sup>1</sup>, H. El Baza<sup>1</sup>, H. Ben Youcef<sup>2</sup>, H. Oudadesse<sup>3</sup>, H. Noukrati<sup>1</sup>, A. Barroug<sup>1,4</sup>

<sup>1</sup> Institute of Biological Sciences (ISSB), Faculty of Medical Sciences, Mohammed VI Polytechnic University (FMS-UM6P), Benguerir, Morocco,

<sup>2</sup> High Throughput Multidisciplinary Research Laboratory (HTMR), Mohammed VI Polytechnic University (UM6P), Benguerir, Morocco,

<sup>3</sup> Univ Rennes, CNRS, ISCR-UMR 6226, F-35000 Rennes, France

<sup>4</sup> Cadi Ayyad University, Faculty of Sciences Semlalia, 2390, 40000, Marrakech, Morocco

### Abstract

Bone infections are serious complications that can arise after orthopedic surgery. Conventional treatments often involve the systemic administration of antibiotics to eradicate the infection. However, this approach has limitations, such as insufficient antibiotic concentrations reaching the site of infection and undesirable systemic side effects<sup>1</sup>. A promising alternative involves using CPCs as local delivery systems for therapeutic agents such as antibiotics. CPCs can be loaded with antibiotics and implanted directly into the infected area, enabling controlled release of the antimicrobial agent. This approach offers several advantages, it ensures a higher concentration of antibiotics at the site of infection, minimizes systemic side effects, and reduces bacterial resistance<sup>2</sup>. The association of CPCs with antibiotics can affect the physicochemical and structural properties of materials. It is therefore important to consider these effects when designing antibiotic-associated CPCs<sup>3,4</sup>.

This work aims to develop an antibacterial bone substitute based on calcium phosphate cement, to prevent the risk of postoperative infections. For this aim, several cement systems were designed, and the effect of incorporating ciprofloxacin on the functional properties, drug delivery, and antibacterial activity was investigated.

The results of the physicochemical characterization showed that adding ciprofloxacin (Cip) antibiotic altered the composition and structure of the designed cement systems, delaying the setting reaction and hence the formation of the reaction product, the apatite phase. Moreover, the injectability was affected by the composition of each cement. Indeed, increasing the ciprofloxacin dose reduced the injectability of the CPC system, while rising for CPC-BG cement and decreasing also for the CPC-BG-Alg cement. The cohesion ability of Cip-loaded CPC-BG and CPC-BG-Alg was excellent, and the pastes retained their shape in the PBS medium. However, the Cip-loaded CPC system cement showed poor cohesion disintegrating the cement pastes when immersed in the PBS solution. The setting times were also impacted by incorporating Cip antibiotic resulting in prolonged setting duration when increasing the amount of Cip.

Furthermore, the ciprofloxacin release kinetic was assessed for each cement, revealing a different release behavior depending on the composition, and the released Cip concentrations were comparable to the CMI and CMB of staphylococcus aureus and Escherichia Coli germs. These findings were confirmed by the assessment of the antibacterial activity using the disk method which revealed that the Cip-loaded cements are efficient for inhibiting the growth of S. Aureus and E. Coli germs.

Through the findings of this work, the functional properties and release behavior of the drug were critically dependent on the additives' nature incorporated into the CPC. It was demonstrated that all the formulated cements exhibited an antibacterial activity allowing their application as drug delivery systems for the local treatment of bone infections.

### References

1. D. Gomes, M. Pereira, A.F. Bettencourt, Osteomyelitis: An overview of antimicrobial therapy, Brazilian J. Pharm. Sci. 49 (2013) 13–27.
2. T. Yu, J. Ye, C. Gao, L. Yu, Y. Wang, Synthesis and drug delivery property of calcium phosphate cement with special crystal morphology, J. Am. Ceram. Soc. 93 (2010) 1241–1244.
3. M. Fosca, J. V. Rau, V. Uskoković, Factors influencing the drug release from calcium phosphate cements, Bioact. Mater. 7(2022) 341–363.
4. M.P. Ginebra, T. Traykova, J.A. Planell, Calcium phosphate cements as bone drug delivery systems: a review, J Control Release. 113 (2006) 102–110.



*The author has expertise in the development of Materials for biomedical applications, her research focuses mainly on developing new materials based on calcium phosphates in the orthopedic field. The author has also expertise in designing biomaterials for the treatment of bone pathologies such as bone infections.*

**Email:** hanaa.mabroum@um6p.ma

## Adaptive Forecasting of Photovoltaic Energy Generation Using LSTM Technique

Meryem Yahyaoui<sup>1</sup>, Mohamed Karom<sup>1</sup>, Hajar Chadli<sup>1</sup>, Khalid Salmi<sup>1</sup>, Mohammed Saber<sup>2</sup>,  
Sara Chadli<sup>1</sup>

<sup>1</sup>Electronics and Systems Laboratory, Faculty of Sciences, Mohammed First, University, Oujda, Morocco

<sup>2</sup>Laboratory Electronics, Computer and Image Systems, National School of Applied Sciences, Mohammed First University, Oujda, Morocco

### Abstract

This paper proposes an innovative approach based on long-short-term memory (LSTM) neural network to perform short-term forecasting of photovoltaic energy generation. Accurate forecasting of PV energy generation is very important for optimum use of solar energy. Differently from traditional models which use merely statistical techniques, the more advanced LSTM technique aims at modeling apparatus focusing on the temporal data with nonlinear and complicated interdependence. In this regard, it incorporates the major operational meteorological variables; irradiance, temperature, humidity, wind speed to understand the energy production fluctuations. Owing to careful hyper parameter tuning, which augments the accuracy of the forecasts while lowering the computational overhead, the model has undergone careful optimization. Given the procedures of using historical data of several years, the model training also ensures enhanced resilience to shocks from unpredictable and sudden climatic changes. For this adaptable capacity, consideration is required because climate change does have influence on the production of solar energy. Bringing this predictive solution into the fold of managing photovoltaic systems allows potential production swings to be predicted accurately, thus enhancing the performance of solar systems. This helps not only in improving operational efficiency but also in enhancing the effectiveness of energy generation. The solution put forward presents considerable enrichment, particularly in improving the efficiency and quickness of the management of PV systems, and adds a flexible and inspiring approach to seasonal changes. Therefore, this technology promotes efficient harnessing of the sun's energy and enhances the energy performance of existing systems.

### References

1. Liu, P.,Quan,F.,Gao,Y.,Alotaibi,B.,Alsenani,T R.,Abuhussain, M. Green energy forecasting using multiheaded convolutional LSTM model for sustainable life, Sustainable Energy Technologies and Assessments.2024,63,2213-1388. doi: 10.1016/j.seta.2024.103609.
2. Abumohsen, M., Youssef owda, A.,owda, M.,Abumihsan, A. Hybrid machine learning model combining of CNN-LSTM-RF for time series forecasting of Solar Power Generation , e-Prime - Advances in Electrical Engineering, Electronics and Energy.2024,9, 2772-6711. doi: 10.1016/j.prime.2024.100636.



*Author has expertise in artificial intelligence, renewable energy control, and grid injection.*

*Meryem Yahyaoui graduated with a degree in mechanical and energy engineering from Mohammed First University. She is currently pursuing her doctorate at the Laboratory of Electronics and Systems at Mohammed First University. Her research interests include artificial intelligence, control of renewable energy systems, and energy injection into the grid.*

**Email:** meryem.yahyaoui@ump.ac.ma

## Contaminants in Soil-Like Material Recovered from the Rehabilitated Landfill of Oujda-Sidi Yahya (Eastern Morocco): A Case Study

Nadia Malki, Mohamed Sbaa, Mourad Arabi, Maryam Slamini, Hamza Kajeiou

Laboratory for Improvement of Agricultural Production, Biotechnology and Environment (LAPABE), Faculty of Science, Mohammed Premier University, PB 717, 60000, BV M6, Oujda, Morocco.

### Abstract

Former closed landfill sites pose significant environmental and health risks, as soil and groundwater contamination from heavy metals and other pollutants can persist for decades after closure. The rehabilitation of these sites is particularly challenging due to extreme conditions, such as poor soil quality, pollution, and instability, which complicate restoration efforts. The former uncontrolled landfill at Sidi Yahya-Oujda in Eastern Morocco, located 7 km southeast of the city near the Algerian border, was active from 1990 to 2005. Spanning approximately 41 hectares, it received between 1.2 and 1.5 million tons of waste in a semi-arid climate. Following its closure, rehabilitation efforts were initiated to consolidate the waste and cover it with compacted silt.

Samples of soil-like material (SLM) were collected from the site to assess the level of contamination in the topsoil (0-40 cm) and to analyze the associated environmental risks. The assessment focused on organic content, pH, electrical conductivity (EC), total dissolved solids (TDS), and heavy metals (Pb, Zn, Cd, Fe). The results revealed an organic content ranging from 0.35% to 14.51%, a pH varying between 6.31 and 7.50, EC levels ranging from 424.89 to 7638  $\mu\text{S}/\text{cm}$ , and TDS levels from 220 to 3850 ppm. The concentrations of heavy metals, particularly Pb, Zn, Cd, and Fe, were found to be moderate to high.

This study highlights the challenges associated with managing old landfills, particularly those established before the implementation of stringent regulations. Despite rehabilitation efforts, the Sidi Yahya site continues to pose contamination risks, primarily due to heavy metals and dissolved substances, which could potentially impact the environment and public health.

**Keywords:** Former uncontrolled landfill; Municipal solid waste; Soil-like material; Contaminants; Physicochemical characterization; Eastern Morocco.

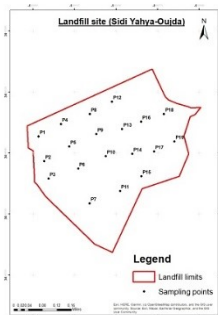

### References

1. Arabi M., et al (2024) : <https://doi.org/10.1051/e3sconf/202452702018>.
2. Hölzle I., (2019): <https://doi.org/10.1016/j.wasman.2018.11.013>.
3. Makuleke P. & Ngole-Jeme V. M., (2020): <https://doi.org/10.1155/2020/8872475>.
4. Somani M., et al (2020): <https://doi.org/10.1016/j.psep.2020.02.010>



Ph.D. student at Mohammed Premier University - Morocco, Faculty of Sciences – Oujda.

Laureate of the Master's formation in Environment and Sustainable Development, Mohammed Premier University of Oujda, Morocco.

Email: [Nadia.malki@ump.ac.maa](mailto:Nadia.malki@ump.ac.maa)



## A Digital Twin framework for a Smart Sustainable City

Miraoui Zayneb<sup>1</sup>, Nasser Abdelkader<sup>1</sup>, Mohcine kodad<sup>2</sup>

<sup>1</sup> Laboratory LaMoN2E, FSO, Team MEGCE HSTO University Mohamed I, Oujda, Maroc.

<sup>2</sup> Laboratory MATSI, HSTO, University Mohamed I, Oujda, Maroc.

### Abstract

As the population continues to grow, and with more people are living in the city every-day, urban governance is becoming increasingly difficult, smartening the city is the step that has been taken lately to integrate digital information and connect management tasks with inhabitants in order to facilitate service access, improve city function and provide a high-quality life for citizens, without forget the environmental sector witch should keep a balance harmony between functionality, technology evolution and sustainable natural environment.

And as a next step in researches, Smart Cities (SC) nowadays need to be modelled in a virtual world and updated with continuously information about everything, everywhere and everyone using internet of things (IoT) technology, several data base storage for backups and feedbacks, also creating an Artificial Intelligence (AI) agent program to establish the possibilities of simulating scenarios, taking decisions and proposing solution to prevent natural disasters, pandemic accidents and to control public events, here it comes the Digital twin role for the Smart city management.

This paper aims to highlight the relation between concepts SC and DT in the literature view introduction, compare multiple DT frameworks for SC based on bibliometric analysis methodology, and as a result, generate a structural architecture DT model, moreover, it present latest new-technologies function in this architecture, to conclude, a discussion section for more feature works on how to take actions in real land in order to establish a Digital Twin City (DTC).

**Keywords:** New applications; Sustainability; Urban management, City modelling.



*Author has expertise in civil engineering along with modelling programs as Autocad and Robotat, also the reinforced concrete design, Road pavement design and dimensioning. And a power point, Microsoft office expert.*

**Email:** zayneb.miraoui24@ump.ac.ma

ID : 76

## Comprehensive Investigation of Neutral, Cationic and Anionic Dye Removal Using Bio-Based Alginate@MMT Hybrid Microcapsules: Assessing the Superiority of Encapsulation over Conventional Adsorption Techniques

Essifi Kamal<sup>1</sup>, Mohamed Brahmi<sup>2</sup>, Abdelqader El Guerraf<sup>3</sup>, Hassan Charri<sup>4</sup>, Abdelghani Boussetta<sup>4</sup>, Abdelouahab El Hadrami<sup>1</sup>, Rachid Brahmi<sup>1</sup>, Amine Moubarik<sup>4</sup>, Abdesselam Tahani<sup>2</sup>

<sup>1</sup>Coordination and Analytical Chemistry Laboratory, Faculty of Sciences, University of Chouaib Doukkali, El Jadida, Morocco.

<sup>2</sup>Laboratory of Applied Chemistry and Environment, Faculty of Sciences and Techniques, Hassan First University, 26002 Settat, Morocco

<sup>3</sup>Physical Chemistry of Natural Resources and Process Team, Laboratory of Applied Chemistry and Environment, Department of Chemistry, Faculty of Sciences, University Mohamed Premier, Oujda, Morocco.

<sup>4</sup>Chemical Processes and Applied Materials Laboratory, Polydisciplinary Faculty, Sultan Moulay Slimane University, 23000 Beni-Mellal, Morocco.

<sup>5</sup>Chemical Processes and Applied Materials Laboratory, Polydisciplinary Faculty, Sultan Moulay Slimane University, 23000 Beni-Mellal, Morocco

### Abstract

This study investigates the removal of neutral, cationic, and anionic substances using bio-based calcium alginate and alginate@montmorillonite (Alg@MMT) hybrid microcapsules through encapsulation and adsorption processes. Experimental results demonstrated that both capsule types exhibit higher encapsulation affinity for cationic substances, followed by neutral and anionic ones. Encapsulation proved more effective than adsorption, with encapsulation capacities being 2 to 3 times greater. These findings highlight the potential of Alg@MMT hybrid microcapsules as a promising eco-friendly material for controlled substance removal and release in water treatment applications.

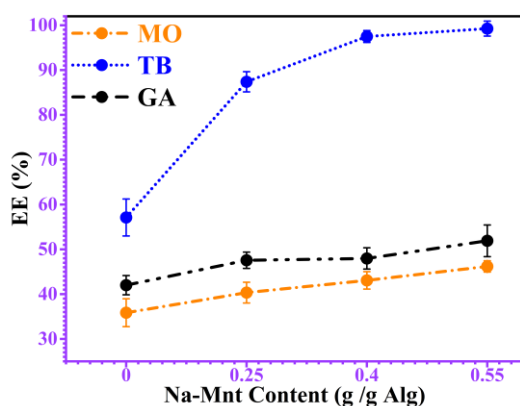

Fig: Effect of Na-Mnt clay content on EE

### References

1. Essifi, K., Brahmi, M., Ed-Daoui, A., Boussetta, A., Benelmostafa, M. H., Dahmani, M., Salhi, S., Moubarik, A., El Bachiri, A. & Tahani, A. (2023). International Journal of Biological Macromolecules, 242, 125011.
2. Brahmi, M., Essifi, K., Bakirhan, N. K., El Bachiri, A., Ouldriane, S. D., & Tahani, A. (2023). Journal of Molecular Liquids, 387, 122635.
3. Essifi, K., Hammani, A., Berraaouan, D., El Bachiri, A., Fauconnier, M. L., & Tahani, A. (2022). Materials Chemistry and Physics, 277, 125569.



**Kamal Essifi** holds a PhD in Physical Chemistry and Materials Science, earned in 2022. He is currently an Assistant Professor at the Faculty of Sciences - Chouaib Doukkali University. His research focuses on the development of advanced hybrid materials for various applications, including the encapsulation and controlled release of active substances. He has more than 20 papers in the field with over 200 Citations.

For inquiry, please contact in:

**Email:** [kamal.essifi.lpapc@gmail.com](mailto:kamal.essifi.lpapc@gmail.com)

## Comparison of the performance of a photovoltaic thermal system cooled by water and by air: a three-dimensional numerical analysis

Yassine El Alami<sup>1</sup>, Bouchaib Zohal<sup>1</sup>, Said Bounouar<sup>1,2</sup>, Elhadi Baghaz<sup>1</sup>

<sup>1</sup>Laboratory of Electronics, Instrumentation and Energetic, Faculty of Sciences, Chouaib Doukkali University, B.P 20, El Jadida, Morocco;

<sup>2</sup>Complex Cyber Physical Systems Laboratory, National Higher School of Arts and Crafts, Hassan II University, Casablanca, Morocco;

### Abstract

High cell temperatures in photovoltaic panels (PV-Ps) compromise electrical efficiency (EE), which can hamper the development of PV systems. To overcome this problem, it is essential to cool the PV-Ps. In this study, we carried out a three-dimensional numerical analysis of a new photovoltaic thermal system (PVT-S) that operates, in the first case, with water cooling and, in the second case, with air cooling, in order to determine the most suitable fluid for PVT-Ss. We also examined the effect of solar irradiance on system performance. For these analyses, we used COMSOL Multiphysics software, which is based on the finite element method (FEM).

The numerical model was validated using numerical and experimental data available in the literature. The results show that the water-cooled system achieves electrical, thermal, and overall efficiencies of 12.66%, 69.79%, and 82.46%, respectively. In contrast, the air-cooled system achieves efficiencies of 10.59%, 39.12%, and 49.71%. In addition, the increase in solar irradiance leads to a rise in cell temperature and electrical power, reaching 3.64°C and 75.93 W respectively for the water-cooled system, and 32.52°C and 44.88 W for the air-cooled system.



My name is **Yassine El Alami** and I'm a PhD student in my third year at the Chouaib Doukkali University, Faculty of Science in El Jadida. My research focuses on solar energy, in particular photovoltaic, thermal and photovoltaic thermal (PVT) systems.

**Email:** [yassineelalami97@gmail.com](mailto:yassineelalami97@gmail.com)

## Innovative Approaches: mHealth Applications and AI in Managing Salt Intake for Hypertension

Sara Ramdani<sup>1</sup>, Nour El Houda Benkaddour<sup>1</sup>, and Intissar Haddiya<sup>1,2</sup>

<sup>1</sup>Laboratory of Epidemiology, Clinical Research and Public Health, Faculty of Medicine and Pharmacy of Oujda, University Mohammed First – Morocco

<sup>2</sup>Department of Nephrology, Mohammed VI University Hospital, Oujda, Morocco. – Morocco

### Abstract

Mobile health (mHealth) applications have become crucial for managing chronic conditions like hypertension (HTN) by enabling dietary monitoring and encouraging healthier behaviors. This literature review examines the role of mHealth apps in lowering salt intake, a significant factor in managing HTN and cardiovascular disease (CVD). Although mHealth interventions have demonstrated potential in raising awareness and fostering behavior change, their effectiveness is often constrained by short follow-up periods and inadequate control groups. Recent advancements in artificial intelligence (AI) algorithms present opportunities to enhance the personalization and accuracy of these applications.

AI contributes to predictive modeling of salt intake, integrates wearable technology for real-time monitoring, employs natural language processing for dietary assessments, and utilizes big data analytics to inform public health policies. Nevertheless, challenges such as data privacy, variability in app-based estimates, and the necessity for robust clinical trials persist. Future research should prioritize long-term studies to evaluate the sustainability and scalability of these interventions in reducing CVD on a global scale.

**Keywords:** Mobile health, Hypertension, Salt intake, Dietary monitoring, Artificial intelligence





## Multifunctional doped bioactive glasses for bone tissue regeneration: characterization, bioactivity, and antioxidant assessment

Zakaria Tabia<sup>1</sup>, Allal Barroug<sup>2</sup>, and Hassan Noukrati<sup>3</sup>

<sup>1</sup>Institute of Biological Sciences (ISSB), Faculty of Medical Sciences (FMS), Mohammed VI Polytechnic University (UM6P), Benguerir, Morocco – Morocco

<sup>2</sup>Cadi Ayyad University, Faculty of Sciences Semlalia, Marrakech, Morocco – Morocco

<sup>3</sup>Institute of Biological Sciences (ISSB), Faculty of Medical Sciences (FMS), Mohammed VI Polytechnic University (UM6P), Benguerir, Morocco – Morocco

### Abstract

Bioactive glasses (BAG) have garnered significant attention over the last decades for their therapeutic effectiveness in bone tissue regeneration (BTR). They are considered as multi-functional biomaterial that not only induces apatite formation on their surface but also can exhibit additional biological functionalities through the local release of therapeutic ions in the defect site. Silica-based BAGs have long been the most studied category due to their high stability, diverse compositional range, and modes of synthesis. Nonetheless, new BAG compositions have emerged recently in the alternative systems that opened new research perspectives in the field of tissue engineering. By incorporating therapeutic ions, such as Zn, Cu, or Mg, these glasses can attain distinct biological properties of interest, such as antioxi- dant, antibacterial, antitumor, etc. In the present work, new compositions of doped BAG are presented for potential dual antioxidant and biomineralization properties. Comprehensive characterizations of these glasses through FT-IR, DSC, XRD, and SEM were conducted. In addition, bioactivity assessments and antioxidant activities were also performed. Results show that all doped glasses, at different percentages, exhibit an amorphous nature related to their disorganized atomic structure. FT-IR analysis indicates minor changes in the struc- tural features of the glasses which can be related to the incorporation of the dopant in the glasses. In addition, all glasses were characterized by rapid biomineralization ability in Sim- ulated Body Fluid (SBF) solution. This was confirmed by FTIR where new bands related to P-O vibrations were detected. Furthermore, the antioxidant assay indicated that doping glasses with XO<sub>2</sub> induced an H<sub>2</sub>O<sub>2</sub> scavenging activity which was more pronounced with increasing doping content. In light of these results, XO<sub>2</sub>-doped BAG can be considered as multifunctional biomaterials for bone tissue regeneration.

**Keywords:** Bone regeneration, bioactive glass, antioxidant, bioactivity



*Email : zakaria.tabia@um6p.ma*

---

ID : 101

## One pot synthesis of polyaniline–silver nanocomposites on cellulosic fibres for active food packaging

Abdelqader El Guerraf<sup>1,2</sup>, Sana Ben Jadi<sup>3</sup>, Imane Ziani<sup>4</sup>, Farooq Sher<sup>5</sup>, Mohammed Bazzaoui<sup>3</sup> and El Arbi Bazzaoui<sup>4</sup>

<sup>1</sup>Laboratory of Applied Chemistry and Environment, Faculty of Sciences and Techniques, Hassan First University, 26002 Settat, Morocco

<sup>2</sup>International Society of Engineering Science and Technology, United Kingdom

<sup>3</sup>Materials and Environmental Laboratory, Faculty of Sciences, Ibn Zohr University, Agadir, Morocco

<sup>4</sup>Laboratory of Applied Chemistry and Environment, Faculty of Sciences, Chemistry Department, Mohammed First University, 60000 Oujda, Morocco

<sup>5</sup>Department of Engineering, School of Science and Technology, Nottingham Trent University, Nottingham NG11 8NS, United Kingdom

### Abstract

A polyaniline–silver nanocomposite (PAni@Ag) modified cellulosic paper was synthesized via in situ chemical oxidative polymerization, using aniline monomer and silver nitrate. During the redox reaction, silver ions oxidize the monomer and are subsequently reduced. The unique properties of these nanocomposites make them particularly suitable for direct contact applications in the food industry. The structural features and formation of the composite on cellulosic fibers were characterized using scanning electron microscopy (SEM), Fourier transform infrared (FTIR) spectroscopy, and X-ray diffraction (XRD). The material was further assessed for its antibacterial activity and its effectiveness as a sensor for detecting toxic volatile organic compounds (VOCs) typically associated with food spoilage. In these composites, the silver content plays a crucial role in enhancing antimicrobial efficacy against both gram-positive *Staphylococcus aureus* and gram-negative *Escherichia coli*. Furthermore, significant variations in the internal resistance of the PAni@Ag composite upon exposure to ammonia, acetone, methanol, and ethanol vapors highlight its outstanding sensing performance.

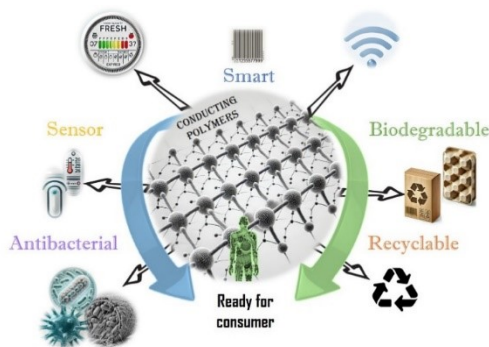

### References

1. A. El Guerraf, S. Ben Jadi, I. Ziani, M. Dalli, F. Sher, M. Bazzaoui, E.A. Bazzaoui, *Industrial & Engineering Chemistry Research* 62.11 (2022): 4540–4553.
2. A. El Guerraf, S. Ben Jadi, N.K. Bakirhan, M. E. Kiymani, M. Bazzaoui, S.A. Ozkan, E.A. Bazzaoui, *Polymer Bulletin* 79.12 (2022): 11543–11566.
3. A. El Guerraf, S. Ben Jadi, Z. Aouzal, M. Bouabdallaoui, N.K. Bakirhan, S.A. Ozkan, M. Bazzaoui, E.A. Bazzaoui, *Journal of Applied Electrochemistry* 52.9 (2022): 1383–1407.
4. I. Ziani, A. El Guerraf, N.E. Bentouhami, M. Brahmi, H., A. El Bachiri, M.L. Fauconnier, S. Ansar, F. Sher, *Biocatalysis and Agricultural Biotechnology* 58 (2024): 103223.
5. A El Guerraf, M Bouabdallaoui, Z Aouzal, S Ben Jadi, NK Bakirhan, M Bazzaoui, SA Ozkan, EA Bazzaoui, *Journal of Electroanalytical Chemistry* 882 (2021): 11503



**Abdelqader El Guerraf**

Passionate research scientist with experience in physical chemistry and electrochemistry. Currently a Senior Lecturer at University Hassan I, with a strong focus on electrosynthesis, electroanalytical techniques, nanomaterials, polymers, metal organic frameworks and protective coatings. Extensive expertise in developing advanced materials and applying cutting-edge spectroscopic and microscopic characterization methods. Dedicated to innovative research and teaching in the fields of material science and electrochemistry.

**Email:** [abdelqader.elguerraf@uhp.ac.ma](mailto:abdelqader.elguerraf@uhp.ac.ma)

ID : 136

## Optimizing CdS Thin Films as Transparent Window Layers in Solar Cells

A. El Hassani<sup>1</sup>, L. Limouny<sup>1</sup>, Y. El Hassouani<sup>1</sup> and S. Dlimi<sup>2</sup>

<sup>1</sup> ENIM, LSTI, Physics Department, Faculty of Sciences and Technics Errachidia, Moulay Ismail University, Meknes, Morocco

<sup>2</sup> Laboratory of Sciences and Technologies of Information and Communication (LSTIC), Team: Microelectronic, Microwaves, Instrumentation and Information (MM2I), Physics Department, Faculty of Sciences, Chouaib Doukkali University, Av. des facultés, El Jadida, 24000, Morocco.

### Abstract

Cadmium sulfide (CdS) thin films play a crucial role as a window layer in solar cells due to their high optical transparency and suitable band gap (~2.4 eV). Positioned at the front of the cell, the CdS window layer allows most of the incident light to pass through while absorbing harmful UV radiation. Its ideal band gap complements the absorber layer, such as in CdTe or CIGS solar cells, facilitating efficient charge carrier separation. Additionally, CdS thin films are typically synthesized via vacuum deposition or chemical methods, offering scalable and cost-effective manufacturing for photovoltaic applications.

**Keywords:** Cadmium sulphide, Thin films, Structural properties, Optical properties, Solar cells.

### References

1. A.E. Görmez, M.A. Basyooni, S.E. Zaki, Y.R. Eker, E. Sönmez, M. Yılmaz, Effect of in-/ex-situ annealing temperature on the optical, structural and gas sensing dynamics of CdS nanostructured thin films, *Superlattices Microstruct.* 142 (2020) 106536.
2. M. Kamalian, E. Hasani, L. Babazadeh Habashi, M. Gholizadeh Arashti, Impact of post-deposition annealing on the optical, electrical, and structural properties of CdS thin films for solar cell applications, *Phys. B Condens. Matter.* 674 (2024) 415524. <https://doi.org/10.1016/j.physb.2023.415524>.
3. S.S. Hoseini, A. Seyedkanani, G. Najafi, A.P. Sasmito, A. Akbarzadeh, Multiscale architected porous materials for renewable energy conversion and storage, *Energy Storage Mater.* 59 (2023) 102768.
4. A. Bosio, G. Rosa, N. Romeo, Past, present and future of the thin film CdTe/CdS solar cells, *Sol. Energy.* 175 (2018) 31–43.
5. M. Isik, H.H. Gullu, S. Delice, M. Parlak, N.M. Gasanly, Structural and temperature-dependent optical properties of thermally evaporated CdS thin films, *Mater. Sci. Semicond. Process.* 93 (2019) 148–152.
6. Q. Li, X. Li, S. Wageh, A.A. Al-Ghamdi, J. Yu, CdS/graphene nanocomposite photocatalysts, *Adv. Energy Mater.* 5 (2015) 1500010.



**Email:** [limouny@gmail.com](mailto:limouny@gmail.com) ; [l.limouny@umi.ac.ma](mailto:l.limouny@umi.ac.ma) (L. Limouny)

## Assessing the seawater quality of a coastal city using fecal indicators and environmental variables (East Mediterranean Coast Moroccan)

Hamza Ngadi<sup>1</sup>, Mostafa Layachi<sup>2</sup>, Ghizlane Azizi<sup>1</sup>, Sara Esseffar<sup>1</sup>, Yassine El Yousfi<sup>3</sup>, Hicham Gueddari<sup>1</sup>, Hamza Loukili<sup>1</sup>, Abderrahmane Rahhou<sup>1</sup>, Chahban Mohamed<sup>1</sup>, Abdelmajid Moumen<sup>1</sup>

<sup>1</sup> Department, Institution, City, Country 1 OLMAN- BGPE, Faculté Pluridisciplinaire de Nador (FPN), Université Mohammed 1er, B.P: 300, Selouane, 62700, Nador, Morocco;

<sup>2</sup> Centre Régional de l'INRH-Nador-, 13 Boulevard Zerktouni BP: 493, Nador, Morocco;

<sup>3</sup> Environmental Management and Civil Engineering Team, ENSAH, Abdelmalek Essaadi University, Morocco

### Abstract

The presence of fecal bacteria in seawater is a crucial bioindicator of fecal pollution. This study assessed microbiological and physicochemical parameters along the coastal area of Ras Kebdana-Saïdia (eastern Morocco) through a comprehensive monitoring program. Data were collected from surface seawater samples taken monthly in 2018 at four designated stations. Bacteriological analyses were conducted using the membrane filtration technique. Results indicated that the highest concentrations of fecal coliforms (log 1.17 cfu/100 mL) and fecal streptococci (log 1.58 cfu/100 mL) were observed during autumn and winter. A significant negative correlation was observed between physicochemical parameters and fecal bacteria levels, confirmed by Pearson's correlation test. Routine monitoring of fecal contamination parameters is recommended to enhance the environmental health of coastal cities.

**Keywords:** Ras Kebdana-Saïdia; seawater; physicochemical parameters; Fecal coliform; Fecal streptococci

### References

1. Abebe, E., Gugsu, G., Ahmed, M Review on major food-borne zoonotic bacterial pathogens. *Journal of Tropical Medicine*. 2020, 19, 467-479.
2. Moukhli, A., Amara, R., El Khamli, A. Bivalve mollusks as bioindicators of pollution in coastal waters: A review from Morocco. *Marine Pollution Bulletin*. 2019, 139, 215-227.
3. Gerba, C. P., Tehobanoglous, G., Tso, J. Fecal Indicator Bacteria: A Review of the Use of E. coli and Enterococci in Water Quality Assessment. *Water Environment Research*. 2017, 89(9), 1831-1844
4. Baker, K. H., LeFevre, N. J., Harwood, V. J. Sources of fecal contamination in coastal waters: Strategies for assessment and management. *Environmental Science & Technology*. 2021, 55(12), 8419-8430



**NGADI Hamza** a doctorate in life and environmental sciences from University Mohamed First, Nador multidisciplinary faculty. He is interested in the study of micropollutants and micro-organisms and their effects on the marine ecosystem. His work focuses on assessing the environmental and microbiological quality of the Moroccan Mediterranean coast.

## Polymer-based additive manufacturing: from definition to assessing the environmental impact

Kawtar Douay, Hicham Fihri-Fassi

Laboratory engineering, industrial Management and Innovation FST, Settat 26000, Morocco

### Abstract

Polymer-based additive manufacturing denotes building a three-dimensional polymer object from a digital blueprint by gradually adding material until the intended size and shape are reached. It has developed from its inception as a rapid prototyping tool to entail more application levels, such as rapid tooling and manufacturing. In today's world, professionals and individuals can use numerous polymer-based additive manufacturing processes, like the FDM process. According to the LCA findings from the literature, the extruder's high temperature and pressure led to particle formation due to chemical reactions, with various TVOC compounds potentially released during the manufacturing. Besides, several factors influence energy consumption, namely the raster angle and the part orientation. Moreover, recycling polymers could be an environmentally friendly solution as it lowers the need for new raw resources (i.e. new raw material extraction) and conserves natural resources, despite obstacles like material variability.

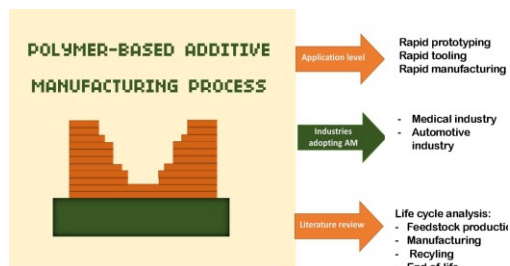

Fig : Graphical abstract

### References

1. Javid, M., Haleem, A., Singh, R.P., Suman, R., Rab, S., 2021. Role of additive manufacturing applications towards environmental sustainability. *Advanced Industrial and Engineering Polymer Research, 3D Printing of Polymers* 4, 312–322. <https://doi.org/10.1016/j.aiepr.2021.07.005>.
2. Karwasz, A., Osinski, F., 2020. Literature review on emissions from additive manufacturing by FDM method and their impact on human health. *Management and Production Engineering Review*. <https://doi.org/10.24425/mper.2020.134933>.
3. Przekop, R.E., Gabriel, E., Pakuła, D., Sztorch, B., 2023. Liquid for Fused Deposition Modeling Technique (L-FDM)—A Revolution in Application Chemicals to 3D Printing Technology: Color and Elements. *Applied Sciences* 13, 7393. <https://doi.org/10.3390/app13137393>.
4. Ulkir, O., 2023. Energy-Consumption-Based Life Cycle Assessment of Additive-Manufactured Product with Different Types of Materials. *Polymers* 15, 1466. <https://doi.org/10.3390/polym15061466>.
5. Zander, N.E., 2019. Recycled Polymer Feedstocks for Material Extrusion Additive Manufacturing, in: *Polymer-Based Manufacturing: Recent Developments*, ACS Symposium Series. American Chemical Society, pp. 37–51. <https://doi.org/10.1021/bk-2019-1315.ch003>.



*Douay Kawtar has expertise in material sciences and mechanical processes, typically in assessing their environmental impact and their sustainability. She is a PhD student in mechanical engineering with a master of research in material science and an engineering degree in industrial engineering. She is a graduate from école des miens de rabat.*

**Email:** [k.douay.doc@uhp.ac.ma](mailto:k.douay.doc@uhp.ac.ma)



## Pistacia Lentiscus Leaf Extract: Investigating the Antioxidant Potential of its Primary Constituents through Experimental and Computational Analysis

Hamza Bouakline<sup>1</sup>, Imane Ziani<sup>1</sup>, Mohammed Elkabous<sup>1</sup>, Yasser Karzazi<sup>1</sup>, Abdesselam Tahani<sup>1</sup>, Ali El Bachiri<sup>1</sup>

<sup>1</sup>Laboratory of Environment and Applied Chemistry (LCAE), Faculty of Sciences, Mohammed First University, Bd Mohamed VI, Oujda 60000, Morocco

### Abstract

This study aimed to assess the antioxidant activity of key components in Pistacia lentiscus leaf (PL) extract through the DPPH• free radical assay. HPLC analysis of the extract identified 27 compounds, with gallic acid (GA), quercetin (QT), and catechin (CT) as the major constituents. The inhibitory concentration (IC<sub>50</sub>) values were 0.0068 mg/ml for gallic acid, 0.0070 mg/ml for quercetin, 0.0148 mg/ml for catechin, and 0.0015 mg/ml for the PL leaf extract, indicating high antioxidative efficacy. Additionally, theoretical calculations using density functional theory (DFT) further clarified these interactions, revealing negative interaction energies of -20.46, -18.95, and -16.19 kcal/mol for GA, QT, and CT, respectively, which corroborate the experimental findings.

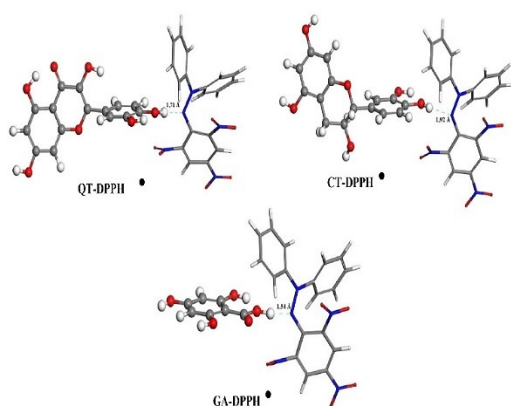

**Fig:** The optimized structure of interacted complexes (a) QT-DPPH, (b) CT-DPPH and (c) GA-DPPH.

### References

1. H. Bouakline, M. Elkabous, I. Ziani, Y. Karzazi, I. A. Tahani, A. El Bachiri, Antioxidative activity of Pistacia lentiscus leaf extract main components: Experimental and theoretical study, Mater. Today Proc. (2022) <https://doi.org/10.1016/j.matpr.2022.07.241>.
2. I. Ziani, H. Bouakline, M.I. Yahyaoui, Y. Belbachir, M.L. Fauconnier, A. Asehraou, A. Tahani, A. Talhaoui, A. El Bachiri, The effect of ethanol/water concentration on phenolic composition, antioxidant, and antimicrobial activities of Rosmarinus tournefortii de Noé hydrodistillation solid residues, J. Food Meas. Charact. (2022). <https://doi.org/10.1007/s11694-022-01722-6>.



**Hamza Bouakline**

A PhD student at faculty of Sciences - Mohammed 1<sup>st</sup> University Oujda, Hamza run research about the effect of the drying process and extraction methods on the bioactive compound of the Medicinal and Aromatic Plants

**Email:** hamzabouakline95@gmail.com / h.bouakline@ump.ac.ma

## Forecasting Lithium-Ion Batteries In Electric Vehicle Fleets

Hafsa Khayrane<sup>1,2</sup>, Spyridon Giazitzis<sup>2</sup>, Mohamed Louzazni<sup>1</sup>, Emanuele Ogliari<sup>2</sup>, Marco Musetta<sup>2</sup>

<sup>1</sup>Science Engineer Laboratory for Energy, National School of Applied Sciences, Chouaib Doukkali University of El Jadida, El Jadida, Morocco

<sup>2</sup>Dipartimento di Energia, Politecnico di Milano, Via La Masa 34, 20156 Milano, Italy

### Abstract

The precise estimation of the SOC is fundamental for the safety and efficiency of batteries, especially for electric vehicles. In this work, a new method for estimating the SOC based on LSTM is proposed, which take advantage of their ability to learn complex temporal sequences. The main innovation consists in the integration of a new input in the LSTM model: the internal resistance of the battery, calculated using the Rint model. This parameter provides additional information on the state of the battery and contributes to improving the accuracy of the estimate. The tests conducted show that the proposed method considerably reduces the estimation errors of the SOC, ensuring greater accuracy and reliability. The implementation of this method can contribute to improving the safety, efficiency, and lifespan of batteries.

**Keywords:** State of Charge, Battery Efficiency, Electric Vehicles, Long Short-Term Memory, Temporal Sequence Learning, Internal Resistance, Battery Management System.



*Email : hafsa\_khayrane00@outlook.com*

---

ID : 201

## Recent Advances in Alginate-Montmorillonite Biomaterials for Fertilizer Encapsulation and Controlled Nutrient Release: A Comprehensive Review

Abdelghani Laamaoui <sup>1,2</sup>, Kamal Essifi <sup>2</sup>, Hanan EL Alaoui-Belghiti<sup>1</sup>

<sup>1</sup> Laboratory of Physical-Chemistry of Materials Chemistry Department, Faculty of Science, Chouaib Doukkali University, El Jadida, Morocco.

<sup>2</sup> Coordination and Analytical Chemistry Laboratory, Faculty of Sciences, University of Chouaib Doukkali, El Jadida, Morocco.

### Abstract

Biomaterials combining alginate, a biodegradable biopolymer, and montmorillonite, a clay mineral, for controlled-release fertilizers (CRFs) offer significant advantages over conventional fertilizers. This synergy enables precise regulation of nutrient release, significantly reduces leaching losses, and prevents excessive nutrient accumulation in the soil.

This review aims to provide a fundamental understanding of the reasons and mechanisms behind developing biomaterials-based organic and mineral substances for encapsulating and controlled-release fertilizers (CRFs). It traces the evolution of these technologies from early approaches to recent trends, highlighting their contributions to agricultural efficiency and environmental sustainability.

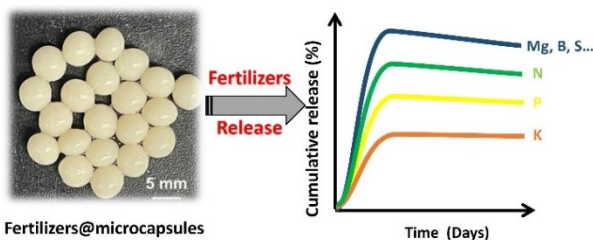

**Shema. Controlled Release Fertilizers Using Alginate-Montmorillonite.**

### References

1. Essifi, K., Brahmi, M., Ed-Daoui, A., Boussetta, A., Benelmostafa, M. H., Dahmani, M., Salhi, S., Moubarik, A., El Bachiri, A. & Tahani, A. (2023). International Journal of Biological Macromolecules, 242, 125011.
2. Brahmi, M., Essifi, K., Bakirhan, N. K., El Bachiri, A., Ouldriane, S. D., & Tahani, A. (2023). Journal of Molecular Liquids, 387, 122635.
3. Essifi, K., Hammani, A., Berraaouan, D., El Bachiri, A., Fauconnier, M. L., & Tahani, A. (2022). Materials Chemistry and Physics, 277, 125569



*I have solid expertise in formulating various types of liquid and solid fertilizers. My experience includes developing advanced encapsulation techniques and controlled-release systems using biomaterials or biocomposites to regulate the release of nutrients. These approaches aim to enhance fertilizer efficiency while minimizing their environmental impact. This expertise also extends to designing innovative solutions to improve the effectiveness and sustainability of agricultural practices.*

**Email:** laamaouiabd@gmail.com

ID : 207

## Low-grade phosphate ore from Benguerir mine: characterization and application for the desulfation of industrial phosphoric acid

Jihad El Makaoui, Abderrahim Najah Elidrissi, Younes Chaali, Mohammed Dahbi, Abdessalam Bouddouch, Abderrahmane Aboulhassane, Driss Zakaria.

Laboratory of Physical Chemistry of Materials (LPCM), Department of Chemistry, Faculty of Science, Chouaib Doukkali University, BP 20, El Jadida, Morocco

### Abstract

Due to the increasing demand for phosphate, particularly for the fertilizer industry, exploring low-grade phosphate ore has become essential. This study evaluates the potential of this ore for the desulfation of industrial phosphoric acid and compares its effectiveness with concentrate phosphate. Phosphate ore from Morocco's Benguerir mining site was analyzed using XRD, XRF, FTIR, and TGA-TDA. Low-grade phosphate primarily consists of calcite and carbonate-fluorapatite, with notable concentrations of CaO (56.3%), and P<sub>2</sub>O<sub>5</sub> (16.43%). Moreover, concentrate phosphate primarily consists of carbonate-fluorapatite and calcite, with notable concentrations of CaO (53%), and P<sub>2</sub>O<sub>5</sub> (28%). In both samples, different bonds such as P–O, and CO<sub>3</sub><sup>2-</sup> were highlighted by FTIR analysis, whereas TGA-TDA indicated carbonate decomposition.

The low-grade is used directly to desulfate phosphoric acid 29% P<sub>2</sub>O<sub>5</sub>. The process used is simple, operating under industrial-scale conditions. The results obtained indicate that low-grade phosphate presents a significant source of calcite and phosphorus. For phosphoric acid desulfation, concentrate phosphate removed 74.8% of sulfates, consequently, 67.5 % of solid rate was removed. Also, 52.8% of organic matter and 48% of fluorine were removed. On the other hand, low-grade phosphate removed 74.8% of sulfates, resulting in 65% of the solid formed being removed. Furthermore, 23.6% of organic matter, and 42% of fluorine. The study demonstrates that low-grade phosphate can be effectively utilized for desulfating phosphoric acid 29% P<sub>2</sub>O<sub>5</sub>. This natural material improves the quality of phosphoric acid while preserving the P<sub>2</sub>O<sub>5</sub> content of the desulfated acid.

This study highlights the importance of exploiting low-grade phosphate ore to improve the quality of phosphoric acid to meet industrial requirements and provide sustainable solutions for the phosphate industry.

**Keywords:** Low-grade phosphate, Phosphoric acid, Desulfation, sustainable resource.



*Jihad El Makaoui is a PhD student in Chemistry at the Faculty of Sciences in El Jadida, Chouaib Doukkali University, Morocco, with expertise in materials sciences. Her research focuses on the valorization of natural materials for the pretreatment of industrial phosphoric acid, specifically targeting both 29%P<sub>2</sub>O<sub>5</sub> and 54%P<sub>2</sub>O<sub>5</sub> concentrations.*

*Based on previous laboratory work and the methodology of experimental design Jihad aims to enhance the quality of phosphoric acid to meet industrial requirements. Her findings indicate that low-grade phosphate ores can effectively desulfate phosphoric acid, addressing the increasing demand for phosphate while promoting environmentally friendly practices within the sector. Jihad's research contributes significantly to sustainable solutions for the fertilizer industry, ensuring that industrial processes align with ecological considerations.*

**Email:** [elmakaoui.j@ucd.ac.ma](mailto:elmakaoui.j@ucd.ac.ma)

## Fluid Dynamics and Electromagnetic Interactions in Radiofrequency Discharges: Insights for Enhanced Plasma Processing

Yassmina Guetbach<sup>1,2</sup>, Sara Said <sup>2</sup>, Meryem grari<sup>1</sup>, El melhaoui ouafae<sup>1,2</sup>, Cifallah Zoheir<sup>1</sup>

<sup>1</sup> Department of Physics, Faculty of Sciences, University of Mohamed Premier, Oujda, Morocco

<sup>2</sup> Research Center, High Studies of Engineering School, EHEI, Oujda, Morocco

### Abstract

This study presents a numerical modeling of a radiofrequency discharge in a two-dimensional inductively coupled plasma reactor. The primary objective is to analyze the discharge characteristics in order to enhance reactor performance and optimize deposition quality. Key parameters such as frequency, pressure, and power are systematically varied to investigate their effects on plasma behavior. The model incorporates fluid dynamics and electromagnetic field interactions, allowing for a detailed examination of electron density, ionization rates, and energy distribution within the plasma. Results indicate that specific combinations of frequency and power significantly improve deposition rates and uniformity, while pressure variations influence the stability and characteristics of the discharge. These findings contribute to a better understanding of plasma processes and offer insights for optimizing industrial applications in thin film deposition and surface modification.

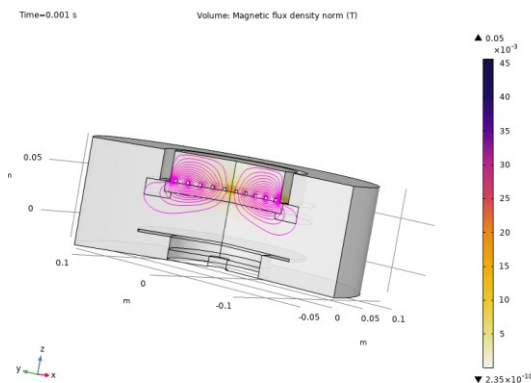

### References

1. Guetbach, Y., Said, S., Grari, M., & Zoheir, C. (2024). Enhancing Plasma Discharge Dynamics through Analysis of Secondary Electron Emission: A Numerical Modeling Approach for Improved Thin Film Deposition. *Scientific African*, e02278.
2. Guetbach, Y., Said, S., Grari, M., & Zoheir, C. (2024). Numerical Analysis of Discharge Plasmas in Inductively Coupled Reactors: Impact of Gas Pressure on Plasma Characteristics. *EHEI-Journal of Science & Technology*, 4(1), J-Sci.
3. Guetbach, Y., grari, M., El melhaoui, O., Said, S., & Zoheir, C. (2024, April). Exploring Plasma Discharge Characteristics in Two-Dimensional Inductively Coupled Reactors: Insights from Maxwellian, Druyvesteyn, and Two-Term Boltzmann Electron Energy Distribution Functions. In *International Conference on Smart Medical, IoT & Artificial Intelligence* (pp. 185-195). Cham: Springer Nature Switzerland.



My name is Yassmina Guetbach, and I am a Ph.D. student at the LETSER Laboratory within the Physics Department of Mohammed the First University in Oujda, Morocco. My research focuses on Plasma Discharge and Renewable Energies, specifically investigating plasma discharge in an ICP (Inductively Coupled Plasma) reactor for applications in thin-film solar cells.

**Email:** [yassmina.guetbach@ump.ac.ma](mailto:yassmina.guetbach@ump.ac.ma)



## Passive Optimization of Solar PV Intermittency for Industrial Applications

Mouhssine Rami<sup>1</sup>, Charaf Hajjaj<sup>2</sup>, Baghaz Elhadi<sup>2</sup>, Samira Touhtouh<sup>1</sup>, Abdelowahed Hajjaji<sup>1</sup>

<sup>1</sup> Laboratory of Engineering Sciences for Energy, National School of Applied Sciences El Jadida, Chouaib Doukkali University, El Jadida, Morocco.

<sup>2</sup> Electronic, Instrumentation and energy Laboratory, Faculty of Science El Jadida, Chouaib Doukkali University, El Jadida, Morocco.

### Abstract

Solar photovoltaic (PV) systems present a valuable opportunity for industries to lower energy costs and reduce carbon emissions. However, the intermittent nature of solar power characterized by daily variations and seasonal fluctuations poses significant challenges for consistently aligning power generation with industrial energy demand. This study investigates passive strategies to optimize the intermittency of solar PV output in an industrial context in Morocco. By adjusting parameters like plant capacity, panel orientation, and tilt angle and, without the addition of active components, such as batteries, which entail significant CAPEX and ongoing operational costs, this research highlights the importance of these parameters on system performance and examines how they can be leveraged for effective optimization.

The case of study results demonstrate that by reducing tilt angle can boost summer production, and a right-sized plant capacity lowers CAPEX, can optimize the LCOE and increasing profitability by over 8%. This passive approach provides an economically feasible solution for enhancing solar PV efficiency in industrial applications, reducing reliance on costly storage systems.



*more than 6 years of experience in engineering, construction and O&M of solar photovoltaic & PtX project.*

**Email:** [ra.mouhssine@gmail.com](mailto:ra.mouhssine@gmail.com)

---

**Performance and degradation assessment of various PV modules exposed outdoors for the short term in two distinct climatic zones in the USA**

Y. Bouasria, M. Zaimi and E. M. Assaid

<sup>1</sup> Laboratory of Instrumentation of Measure and Control, Department of Physics, Faculty of Sciences, Chouaib Doukkali University (UCD), P. O. Box 20 El Jadida, Morocco

**Abstract**

This study examines the degradation of photovoltaic (PV) modules based on crystalline silicon (p-Si and c-Si) and thin-film technologies, covering three specific types: a-Si/ $\mu$ c-Si, HIT, and CIGS. These PV modules were operated outdoors for a short-term period spanning three years in two distinct climatic zones in the United States. The outdoor exposure was divided into two sub-periods: the first began on January 21, 2011, and ended on March 4, 2012, in Cocoa, while the second started on December 20, 2012, and concluded on January 20, 2014, in Eugene [1,2]. The degradation analysis focused on factors such as reductions in maximum power, the degradation of current and voltage at key points of the I-V curve, and changes in the shape of the I-V and P-V characteristics. The results revealed that c-Si and p-Si PV modules experienced a slight performance decline, with degradation rates (DR) of 0.87%/year and 1.01%/year, respectively. Thin-film technologies showed higher degradation rates, with a-Si/ $\mu$ c-Si at 3.26%/year, CIGS at 2.45%/year, and HIT at 1.75%/year. Additionally, the study analyzed the degradation of key points on the I-V curve over the entire period and presented the effects of degradation on the I-V and P-V curves between two time points spaced approximately 30 months apart.

**Keywords:** PV module; Degradation rate; Crystalline silicon; Thin-film technologies.

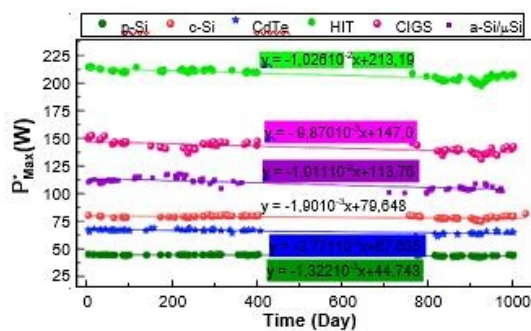

**Fig: Evolution of the effective maximum power for different PV module technologies**

**References**

1. Marion W, Anderberg A, Deline C, Glick S, Muller M, Perrin G, et al. User’s Manual for Data for Validating Models for PV Module Performance. 2014.
2. Marion B, Anderberg A, Deline C, del Cueto J, Muller M, Perrin G, et al. New data set for validating PV module performance models. 2014 IEEE 40th Photovoltaic Specialist Conference (PVSC), Denver, CO, USA: IEEE; 2014, p. 1362–6.



Author has expertise in the analysis of the effects of degradation and aging of different photovoltaic module technologies. Their research includes an in-depth study of polycrystalline silicon and thin-film PV modules, operating under real conditions

**Email :** bouasria.yousseff@gmail.com

ID : 231

## Physicochemical and radiological assessment of phosphogypsum effluents from phosphoric acid production: Environmental impact on Morocco’s El Jadida coastal province

Fatima Ezzahra Arhouni<sup>1</sup>, Saad Ouakkas<sup>1</sup>, Maged Ahmed Saleh Abdo<sup>1</sup>, Mohamed Elhadi Bouhssa<sup>1</sup>, Aziz Boukhair<sup>1,2</sup>

<sup>1</sup>Laboratory of Nuclear, Atomic, Molecular, Mechanical and Energetic Physics, Department of Physics, Faculty of Sciences, Chouaib Doukkali University, 24000 El Jadida, Morocco.

<sup>2</sup>Regional Center of the Trades of Education and Training, Casablanca-Settat, Morocco

### Abstract

This study evaluates the environmental impacts of liquid effluents from phosphoric acid production on Morocco’s El Jadida coastal province, focusing on physicochemical, heavy metal, and radiological contamination in phosphogypsum discharges. Analyzed parameters include pH, conductivity, salinity, turbidity, hardness, nitrate, nitrite, orthophosphate, and a suite of heavy metals. Radiological analyses were conducted using gamma spectrometry to detect isotopes of <sup>238</sup>U, <sup>232</sup>Th, and <sup>226</sup>Ra, while radon concentrations were measured with LR-115 solid-state detectors. Results indicate that the effluents are highly acidic, with an average pH of 1.8, and contain elevated concentrations of fluoride, phosphorus, and radiological elements. These findings underline the need for enhanced treatment measures to mitigate environmental and health impacts of industrial discharges in coastal zones.

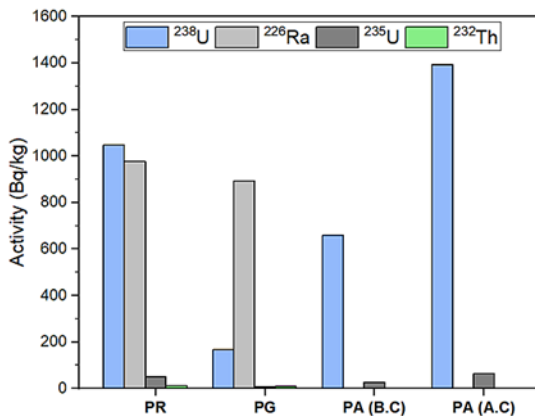

Fig: Variation of the specific activities of the main radionuclides obtained for Khouribga PR, PG and PA

### References

1. Becker P (1989) Phosphates and phosphoric acid: raw materials, Technology and Economics of the Wet Processes, 2nd edn. MarcelDecker Inc., NewYork.
2. Rutherford PM, Dudas MJ, Samek RA (1994) Environmental impacts of phosphogypsum. Sci Total Environ 149:1–38.
3. Azouazi M, Ouahidi Y, Fakhi S et al (2001) Natural radioactivity in phosphates, phosphogypsum and natural waters in Morocco. J Environ Radioact 54(2):231–242.



*Fatima Ezzahra Arhouni has expertise in environmental monitoring and valorization, specializing in assessing contaminants in industrial by-products like phosphogypsum. They utilize advanced analytical techniques to evaluate environmental impact and explore sustainable waste repurposing methods, contributing to global sustainable development goals.*

**Email:** arhouni.f@ucd.ac.ma

ID : 232

## Genome Mining as a Tool for Biopolymer Discovery in Biomaterials

Badre Eddine Halimi<sup>1</sup>, Allal Barroug<sup>1,2</sup>, Rachid Elfatimy<sup>1</sup><sup>1</sup>Mohammed VI Polytechnic University Faculty of Medical Sciences (FMS), Benguerir, Morocco<sup>2</sup>Cadi Ayyad University, Faculty of Sciences Semlalia, LPCME, Marrakesh, Morocco

## Abstract

Genome mining, the systematic exploration of genomic data to discover novel biomolecules, has emerged as a transformative approach for identifying bacteria as producers of glycosaminoglycan (GAG)-like biopolymers<sup>1</sup>. These biopolymers, including hyaluronic acid and heparosan, have significant biomedical applications, particularly in tissue engineering and drug delivery<sup>2</sup>.

In this context, bacterial GAG-like biopolymers were identified using genome mining. Besides, laboratory characterization confirmed the production of GAG-like biopolymers through-screened bacteria. These substances are structurally analogous to natural extracellular matrix components, making them suitable biomaterials for clinical applications such as drug delivery systems<sup>3</sup>. The selected bacteria provide metabolic pathways that can be harnessed to synthesize polysaccharides with desirable properties, in terms of biocompatibility, biodegradability, and hydrogel-forming capabilities<sup>4</sup>.

The main biosynthetic pathways in bacterial strains were defined, enabling the optimization of GAG-like polymer production. These biomaterials hold great potential as carriers for controlled drug release, enhancing therapeutic efficacy while minimizing side effects<sup>5</sup>. Furthermore, the inherent adaptability of bacteria species to diverse environmental conditions highlights their value in scalable biotechnological applications.

In summary, some screened bacterial genus represent an untapped resource in biomaterials research, with significant potential to advance drug delivery systems and other biomedical technologies.

## References

1. Bachmann, B. O., Van Lanen, S. G., & Baltz, R. H. (2014). Microbial genome mining for accelerated natural products discovery: is a renaissance in the making? *Journal of industrial microbiology & biotechnology*, 41(2), 175–184. <https://doi.org/10.1007/s10295-013-1389-9>
2. Hinchliffe, J. D., Parassini Madappura, A., Syed Mohamed, S. M. D., & Roy, I. (2021). Biomedical Applications of Bacteria-Derived Polymers. *Polymers*, 13(7), 1081.
3. Bakhshandeh, B., Mohammadipanah, F., Mirtaleb, M. S., Gazani, M. M., Nateghi, S. S., & Abbasi, P. (2023). Bacterial biopolymers in tissue engineering and regenerative medicine; current applications and future perspective. *Biocatalysis and Agricultural Biotechnology*, 102928.
4. Zarrintaj, P., Seidi, F., Azarfam, M. Y., Yazdi, M. K., Erfani, A., Barani, M., ... & Mozafari, M. (2023). Biopolymer-based composites for tissue engineering applications: A basis for future opportunities. *Composites Part B: Engineering*, 258, 110701.
5. Tören, E., Buzgo, M., Mazari, A. A., & Khan, M. Z. (2024). Recent advances in biopolymer based electrospun nanomaterials for drug delivery systems. *Polymers for Advanced Technologies*, 35(3), e6309.



**Badre Eddine Halimi** is currently a third-year Ph.D. student in the Biomaterials and Engineering Lab at the Faculty of Medical Sciences, UM6P Benguerir. His research focuses on developing novel bacterial biopolymers and exploring their applications in the medical field. This work aims to investigate and optimize the association of biopolymers with drugs to achieve sustained and controlled release, enabling effective drug delivery system for bone tissue.

Email : badreeddine.halimi@um6p.ma

---

**Topic 2: Advances in Mechanical Engineering and  
Electronic Systems: Innovations and Applications**

---

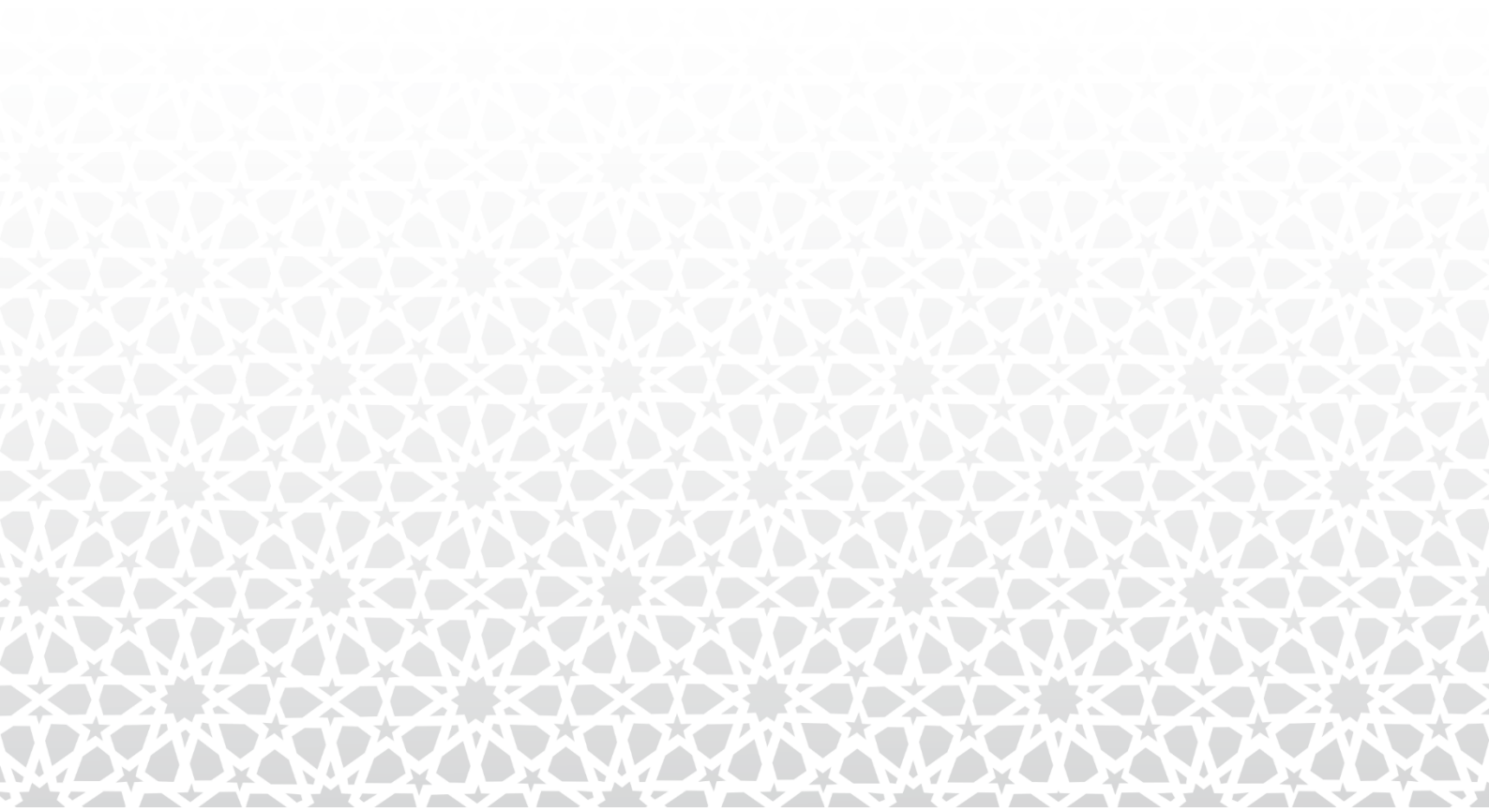



## Enhancing Monte Carlo Simulation Efficiency in Radiotherapy through Feedforward and Inverse Neural Networks

Sennan Nour-Eddine, Abdelkader El Hamli, Abdelilah Moussa

Laboratory of Physics of Matter and Radiation, Department of Physics, Mohammed I University, Faculty of Sciences, Oujda, Morocco

### Abstract

Monte Carlo methods are essential in radiation physics, particularly for simulating ionizing radiation transport in radiotherapy. However, these simulations, especially when modeling photon beams interactions, can be both computationally expensive and time consuming<sup>1</sup>. The main goal of this work is to apply a deep learning model to optimize beam parameter selection, thereby reducing the number of simulations needed to construct our simulation model for linear accelerator simulations and improving the efficiency and accuracy of Monte Carlo simulations<sup>2</sup>. The results of this work indicate that the Feed forward Neural Network (FNN) model performs well on both training and test datasets, explaining approximately 92% of the variance. It demonstrates a low error rate and shows strong correlation with unseen data in the test set. Additionally, our analysis utilizes an inverse neural network to predict primary beam input parameters based on the desired value of gamma index. The results from the inverse and the forward neural network were compared, showing significant agreement between the models and validating the inverse model's accuracy and reliability in simulating real system behavior. This result will be foundational for constructing a model that integrates both inverse and forward neural networks, enabling the creation of an "inverse design" framework. Furthermore, the weights of each parameter distribution within the primary beam parameters were analyzed using the gradient boosting model, offering insights into their relative importance in photon transport simulations.

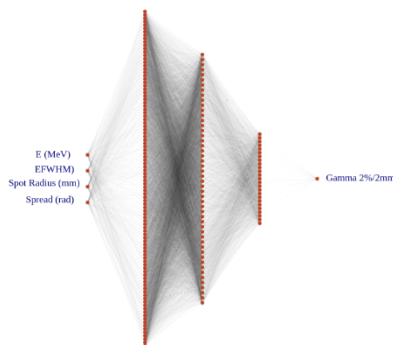

Neural Network Model Architecture for Gamma Index Prediction Based on Radiation Properties

### References

1. Andreo, P. (2018). Monte carlo simulations in radiotherapy dosimetry. *Radiation Oncology*, 131-15.
2. Men, K., Dai, J., & Li, Y. (2017). Deep learning in the medical applications of ionizing radiation: Emerging issues and potential pitfalls. *Medical Physics*, 44(7), e91-e96. DOI: 10.1002/mp.12334



*Sennan Nour-Eddine is a PhD student in the Department of Physics at Mohammed I University, Faculty of Sciences, Oujda. Currently, they are conducting research within the PMR Laboratory (Physics of Matter and Radiation), with a specific focus on advancing techniques in FLASH radiotherapy. Their work aims to explore and optimize this emerging high-dose radiation therapy method, which holds promise for more effective cancer treatment with reduced side effects.*

*Email: [nour-eddine.sennan@ump.ac.ma](mailto:nour-eddine.sennan@ump.ac.ma)*

## Computational Fluid Dynamics Analysis of Internal Cooling Techniques in Aeronautical Gas Turbines

Kamal Abouelmajd<sup>1</sup>, Ismail Lagrat<sup>1</sup>, Salim Zahid<sup>1</sup>, Assel Thami Lahlou<sup>1</sup> and Hamid Mounir<sup>2</sup>

<sup>1</sup> Laboratory of Advanced Systems Engineering, National School of Applied Sciences, Ibn Tofail University, B.P241, Kenitra, Morocco

<sup>2</sup> Morocco Research Team EMISys, Research Centre ENGINEERING 3S, Mohammadia School of Engineers, Mohamed V University, Avenue Ibn Sina B.P 765, Rabat, Morocco...

### Abstract

This research investigates internal cooling strategies for aeronautical gas turbine blades using computational fluid dynamics (CFD) simulations with ANSYS Fluent. It examines how varying coolant injection rates influence temperature and pressure distributions within the blades. The study finds that an injection rate around  $M=1$  is optimal for achieving the lowest interior blade temperature, while moderate rates are most effective for managing wall and outlet temperatures. Higher injection rates significantly increase internal and wall pressures, particularly beyond  $M=1$ , highlighting the need for careful balance. Although higher injection rates improve cooling efficiency, none achieve complete efficiency, emphasizing the importance of optimizing injection rates within practical limits. These findings underscore the necessity of balancing injection rates to optimize turbine cooling.

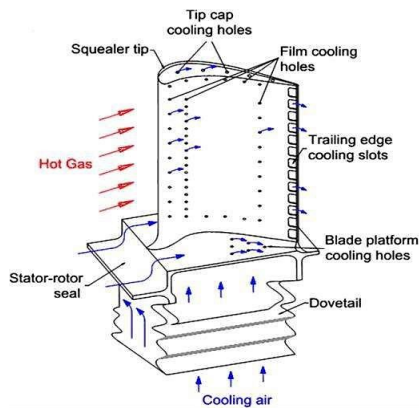

Gas turbine blade cooling schematic

### References

1. L. Zhang, B. Qian, C. Zhang, J. Mao, and H. Fan, "Numerical study on the cooling characteristics of cat-ear-shaped film-cooling holes on turbine blades," *Case Studies in Thermal Engineering*, vol. 36, p. 102050, Aug. 2022.
2. S. Irfan Ahmed, P. Kumar Balguri, D. Govardhan, and S. Habeeb, "Numerical study and heat transfer analysis of nickel-chromium and titanium carbide gas turbine blades cooling," *Materials Today: Proceedings*, vol. 62, pp. 2709–2713, 2022.
3. D. Cherrared, "NUMERICAL SIMULATION OF FILM COOLING A TURBINE BLADE THROUGH A ROW OF HOLES," *Journal of Thermal Engineering*, vol. 3, no. 2, pp. 1110–1110, Apr. 2017.
4. M. Dey, P. Jindal, and A. K. Roy, "Numerical Investigation of Film Cooling Effectiveness in Turbine Blades," *American Journal of Fluid Dynamics*, 2016.
5. H. I. H. Saravanamuttoo, G. F. C. Rogers, H. Cohen, P. Straznicky, and A. Nix, *Gas turbine theory*, 7th edition. Harlow; New York; Toronto: Pearson, 2017.
6. F. R. Menter, "Two-equation eddy-viscosity turbulence models for engineering applications," *AIAA Journal*, vol. 32, no. 8, pp. 1598–1605, Aug. 1994



**Kamal ABOUELMAJD** has expertise in Fluid Mechanics, 3D Simulation, CFD Simulations, Aeronautics, Aeronautical Engineering, and Compressible Flow.

**Email :** kamal.abouelmajd@uit.ac.ma

## Investigation of the magnetized dusty plasma sheath in the presence of non-extensive electrons and two species of positive ions

Zakariae Eljabiri, Omar El ghani, Ismael Driouch

*National School of Applied Sciences, University Abdelmalek Assaadi, Ajdir Al-Hoceima, Morocco*

### Abstract

This work numerically investigates the magnetized complex plasma sheath problem with two species of positive ions. The sheath constituents include thermodynamic non-equilibrium electrons governed by the Tsallis distribution, dynamically charged dust grains treated as cold fluids, and positive ions (heavy ions  $Ar^+$  and light ions  $He^+$ ), also considered as cold fluids. The results highlight the impact of a second ion on sheath characteristics, including electrical potential, dust and ion dynamics, and sheath width. The study focuses on three types of electrons: sub-extensive ( $q > 1$ ), Maxwellian ( $q = 1$ ), and super-extensive ( $q < 1$ ). Notably, the presence of two positive ions significantly influences the structure and dynamics of the sheath components in the case of super-extensive electrons.

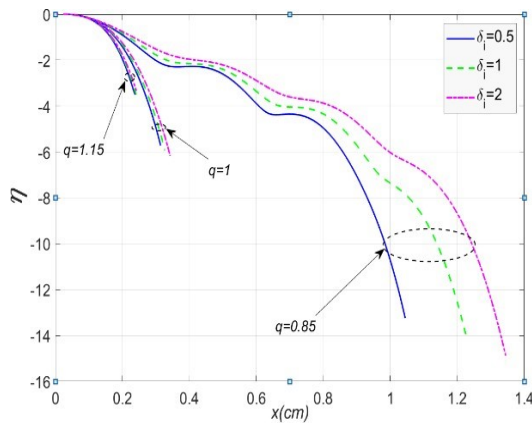

**Normalized sheath potential profile for different values of parameter  $q$ , and ratio  $\delta_i = n_{0,Ar^+} / n_{0,He^+}$**

### References

1. Foroutan, G. (2010). Fluid simulation of an electrostatic plasma sheath with two species of positive ions and charged nanoparticles. *Physics of Plasmas*, 11.
2. Driouch, I., H. Chatei, & M. El Kaouini. (2011). Properties of Sheath in Magnetized Dusty Plasmas with two Species of Positive Ions. *Int. Rev. Phys*, 7.
3. Fouial, N. e. (2016). Bohm criterion in dusty plasmas with two species of positive ions and non-thermal electrons. *Physics of Plasmas*, 11.
4. Hatami, M. a. (2022). Characteristics of plasma sheath in (Franklin, 2001) multi-component plasmas with three-ion species. *Scientific Reports*, 6905.
5. Franklin, RN. (2001). The transition from collisionless to collisional in active low-temperature plasmas with more than one species of positive ion generated by electron impact and the Bohm criterion. *Journal of Physics D: Applied Physics*, 1959.



*Zakariae Eljabiri has expertise in plasma physics, particularly in the study of dusty plasma and magnetized plasma sheaths. With a focus on non-extensive thermodynamics and numerical simulations, the author has contributed to understanding the dynamics of multi-ion systems in complex plasma environments. Their research addresses the interactions between dust particles, ions, and electrons, with applications in space science and fusion research.*

**Email:** zakariae.eljabiri@etu.uae.ac.ma

ID : 20

## Impact of Electric Vehicle Integration on the Moroccan Energy Demand by 2050 Using Energyplan: A Scenario-Based Analysis

Mouad KARMOUN, Wafae ARFAOUI, Smail ZOUGGAR, Aboubekr ALLAM,  
Hassan ZAHBOUNE, Mohamed Elhafyani, Taoufik Ouchbel, and El Fahssi Mohammed

University Mohammed I, School of Technology, Laboratory of Electrical Engineering and Maintenance (LEEM).

### Abstract

This paper analyses the impact of the integration of electric vehicles (EV) on the Moroccan electricity grid by 2050 using EnergyPLAN software. Based on the national electricity demand profiles of Morocco, the production profiles of conventional power plants, as well as the renewable energy production modelled using the software System Advisor Model (SAM), we propose different scenarios for EV integration. The VE consumption profile was constructed from socio-economic data and using artificial neural networks (NRNs) projections, covering 1990–2050. Six scenarios of EV penetration in the Moroccan transport sector are explored, ranging from non-adoption to complete conversion of vehicle fleet to EV by 2050. These scenarios are based on predictions of vehicle numbers, average kilometres traveled, and energy consumption. In addition, the study takes into account an annual increase of 5% in electricity demand as projected by the Ministry of Energy, Mines, and the Environment. Finally, statistical methods were applied to accurately determine the VE consumption profile for each scenario. The overall analysis aims to provide information on the constraints, challenges, and opportunities related to the massive integration of electric vehicles into the Moroccan electricity grid, considering the balance between energy production and consumption.

### References

1. Alshogeathri, "VEHICLE-TO-GRID (V2G) INTEGRATION WITH THE POWER GRID USING A FUZZY LOGIC CONTROLLER."
2. "Vehicle-to-Grid Technology and Its Suitability for the Moroccan National Grid.Pdf."
3. Ruseruka et al., "An Investigation of Factors Influencing Electric Vehicles Charging Needs."
4. Lund et al., "EnergyPLAN – Advanced Analysis of Smart Energy Systems"



*Mouad Karmoun is a PhD student specializing in renewable energy, with a research focus on the energy transition by 2050. His work involves exploring scenarios for the integration of electric vehicles (EVs) into energy systems, assessing the impact on energy demand, grid stability, and efficiency. With a background in energy modeling, Karmoun's research aims to identify sustainable solutions for EV deployment and develop strategies that enhance grid integration. His expertise spans the fields of energy transition, electric vehicle impact analysis, and sustainable energy planning.*

**Email:** [mourad.karmoun@ump.ac.ma](mailto:mourad.karmoun@ump.ac.ma)

## A finite volume method for coupled models of suspended and bed-load transport in shallow water flows

Mohammed Frihessane, Ouafae Boulerhcha, Salah Daoudi

Laboratoire de Mécanique et Energétique, UMP-Oujda

### Abstract

A river with a given water flow velocity, and a bed composed of sediments of varying sizes, will simultaneously have its lighter grains transported by suspension and heavier grains transported by bed load. This phenomenon is governed by the Saint Venant equations for flow coupled with the transport diffusion equation for suspended particles and the bed morphology change equation for bed load transport. In the sediment transport model, erosion and deposition are treated independently, so the sediment flux is given by the difference between the mass of the sediments that are deposited and those that are eroded. The resulting system of highly nonlinear partial differential equations is discretized using the finite volume method on unstructured meshes and the SRNH scheme, which is a second order scheme in both time and space. In order to optimize the calculations we use an adapted mesh procedure which refines the mesh in areas where the concentration gradients are significant. The developed model is used to investigate a variety of problems involving coupled flow and sediment transport including channel initiation and dame break.

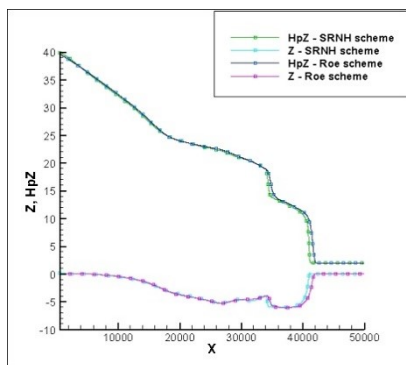

Fig: Dame break at  $t=20$  mn: Water free surface and bed profiles.

### References

6. F. Benkhaldoun & *all.* Int. J. Numer. Methods Fluids 72 (2013) 967–993
7. S. Jelti, M. Boulerhcha, Math. & Comp. in Simulation 197 (2022) 253–276.
8. Weiming Wu, Computational River Dynamics, Taylor and Francis, 2008.



Mohammed Frihessane has expertise in :

- Computational fluid dynamic.
- Shallow water flow.
- Sediment transport by suspension and bed-load.

Email: mohammed.frihessane@ump.ac.ma



ID : 46

## Study of the Mechanical Properties of Mortars: A Study Using Destructive and Non-Destructive Methods

Abeslam El ballouti, Zakaria Tahri

Laboratory of Applied Sciences, National School of Applied Sciences AL Hoceima, Abdelmalek Essaâdi University, Tetouan, Morocco.

### Abstract

The development of non-destructive methods to provide faster and more accurate results is a key objective for many researchers. The aim of this study is to demonstrate that the velocity of ultrasound can be used as a reliable diagnostic tool to evaluate the mechanical properties of mortars based on treated wastewater in the short and long term.

The mechanical properties of mortars based on treated wastewater determined by the destructive method are compared with those determined by the non-destructive method.

High values of ultrasonic velocity indicate better quality of mortars based on treated wastewater, and both destructive and non-destructive methods show a strong correlation in the long term.

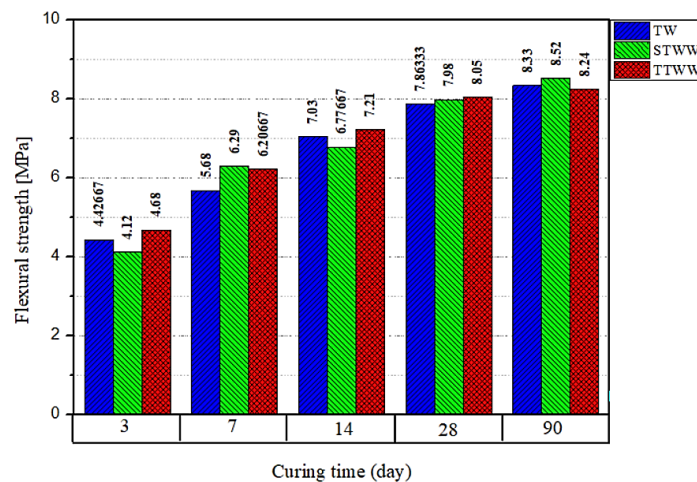

Author has expertise in Civil Engineering and Materials Science: Their work involves studying the physical and mechanical properties of construction materials, including the use of ultrasonic pulse velocity (UPV) to assess material quality.

They explore the use of treated wastewater in construction, aiming to find sustainable alternatives to potable water in mortar production.

They are involved in monitoring the long-term performance and durability of construction materials using both destructive and non-destructive methods.

**Email:** abdslam.elballouti@etu.uae.ac.ma

## Topological Interface States in photonic multilayered structure based on bandgap inversion symmetry

Noura Ezzahni, Mohammed El Aouni, Soufyane Khattou, Afaf Bouzidi Madiha Amrani, El Houssaine El Boudouti

*LPMR, Departement de Physique, Faculté des sciences, Université Mohammed I, Oujda, Morocco*

### Abstract

Topological photonic materials are designed to manipulate light propagation by exploring topological properties. The main feature of these topological systems relies in the presence of topologically protected edge states, where photons can propagate along the material surfaces in a robust manner, enabling robust and controlled manipulation of electromagnetic waves<sup>1,2</sup>. Their ability to resist to perturbations and precisely to control light makes them a promising technology for the future of photonics.

In this work, we propose a one-dimensional (1D) photonic crystal (PC) heterostructure, composed of two concatenated binary or quaternary superlattices for the generation and manipulation of topological interface states. This design is based on the Su–Schrieffer–Heeger (SSH) model, which accounts for the topological properties of many 1D periodic structures<sup>1,3</sup>. By tuning the thickness ratio of the unit cells in these superlattices, we are able to design interface states in different band gaps for different incidence angles. In the 1D SSH model, an interface state will exist inside a bandgap by concatenating two periodic lattices with different topological invariants<sup>4</sup>. This can be assured by the bandgap inversion process around a Dirac point (closing and reopening of the gaps). The existence of topological states discussed here, is based on the analysis of the symmetry of the band-edge states and the Zak phase of each band in the infinite PC. This approach is equivalent to an analysis of the sign of the reflection phase in two gaps surrounding a bulk band. These modes are successfully realized at the interface when two conditions are satisfied: the two systems share common gaps; and the symmetry of the band-edge states are opposite. The bandgap inversion mechanism allows the generation of an interface state which remains robust and protected against any perturbation that does not change the underlying topological invariants of the structures.

### References

1. M. Esmann et al., A Topological View on Optical and Phononic Fabry–Perot Microcavities through the Su–Schrieffer–Heeger Model. *Appl. Sci.* 8, 527(2018)
2. S. Khattou et al, Flat band induced topological photonic Tamm states in stubbed structures: Theory and experiment. *Phys Rev B* 107, 125405 (2023).
3. N. J. Bianchi et al., Optical states in a 1D superlattice with multiple photonic crystal Interfaces. *J. Opt.* 22, 065101 (2020).
4. Z. Lai et al., The Nested Topological Band-Gap Structure for the Periodic Domain Walls in a Photonic Super-Lattice. *Crystals* 14, 757 (2024)



*Author has expertise in functional materials, photonics, sensors, and biosensors based on 1D photonic crystals.*

*Email: ezzahninoura16@gmail.com*

## Towards an optimized braking system using topology optimization, thermal and durability analysis

M. H. Aniyou, Prof. H. Fihri-Fassi

Laboratory IMII, Team ECEI, University Hassan First, FST-Settat

### Abstract

**Keywords:** Brake Systems, Design optimization, Material optimization, Topology optimization, Finite elements analysis, sustainability, Additive manufacturing.

### References

1. H. Fihri-Fassi, Hadji Aniyou, "Towards an Optimal Motor Mounting Bracket Using Topology Optimization Combined with Sustainability and Manufacturing Cost Analysis", Management and Production Engineering Review, Volume 14 (4) 109–116,2023
2. Asim Rashid, Niclas Strömberg " Sequential Simulation of Thermal Stresses in Disc Brakes for Repeated Braking", Proceedings of the Institution of Mechanical Engineers Part J Journal of Engineering Tribology · August 2013
3. Alampally Sainath, Prathamesh Mahesh Dehadray, P. Bharath, Lokavarapu Bhaskara Rao," The thermal and stress analysis of disc brake" Materials Science and Engineering,2020
4. Ali Belhocine, Abd Rahim Abu Bakar & Mostefa Bouchetara, "Thermal and structural analysis of disc brake assembly during single stop braking event", Australian Journal of Mechanical Engineering, 2015
5. M.J. Han, Jae " Coupled thermo-mechanical analysis and shape optimization for reducing uneven wear of brake pads" Int. J. Automotive Technol., 18 (2017), pp. 1027-1035.



*HADJI ANIYOU is a PhD student in Physics and Engineering Sciences at Hassan First University, FST-Settat. His research focuses on topology optimization for additive manufacturing, aiming to enhance design efficiency and sustainability in engineering applications. ANIYOU has contributed to the field with his paper, "Towards an Optimal Motor Mounting Bracket Using Topology Optimization Combined with Sustainability and Manufacturing Cost Analysis," which highlights innovative approaches to optimizing component design while considering environmental impacts and cost efficiency. In addition to his thesis work, ANIYOU is engaged in ongoing research titled "Towards an Optimized Braking System Using Topology Optimization, Thermal and Durability Analysis." This project explores advanced methodologies to improve braking system performance through optimization strategies.*

*He holds an Engineer's Degree in Mechanical Engineering from Hassan II University, ENSAM Casablanca, where he developed a solid foundation in mechanics and materials science. Passionate about integrating engineering principles with sustainable practices, ANIYOU aspires to contribute to the advancement of smart manufacturing technologies.*

**Email:** h.aniyou@uhp.ac.ma

## Antenna design and characterization for 6G technology

Abdeddaim Rguibi, Pr. Asmaa Zugari

*Intelligent Systems Design Laboratory, Faculty of sciences, University Abdelmaled Essaadi, Tetouan, Morocco.*

### Abstract

The world knows a fast evolution day by day mainly in wireless technologies due to the desire to meet the data traffic needs increasing. 6G technology Researchers aim to face the challenges based on exploiting new frequencies bands as sub-THz and THz, using appropriate material and improving the devices abilities, between the important devices should improve there is the antenna that plays a crucial role in sending and receiving this huge data rate. Therefore, this paper aimed to design a patch antenna using CST in a band range [ 0.5THz -0.94THz] at the resonance frequency 0.72 THz, with a patch size 127.9  $\mu\text{m}$  \* 120  $\mu\text{m}$ , silicon substrate with a dielectric constant 11.9 and dimensions 300  $\mu\text{m}$  \* 200  $\mu\text{m}$ , to present the effect of graphene on the antennas behavior and the ability of THz to suit 6G application.

First, the patch material was copper, to optimize the antenna behavior at the resonance frequency the used technic was antenna geometry evolution, that gave respectable results: gain 5 dBi in E plan and 4.48 in H plan, S11 parameter equal -16 dB and the real part of the input impedance 48.48  $\Omega$ .

Second, the patch material was graphene, using the same antennas dimensions before applying antenna geometry evolution method, playing with graphene characteristics until getting the appropriated ones, was able to improve the antennas outcomes: gain more than 5 dBi in E plan and more than 4.48dBi in H plan, S11 parameter -32 dB and the real part of the input impedance 49.7 so near to the desired value 50 $\Omega$ .

Finally, the simulation outcomes of return loss, gain, radiation pattern and input impedance show the ability of the proposed antenna to support 6G applications in THz, and the importance of graphene to improve the antennas performance without antenna geometry evolution.

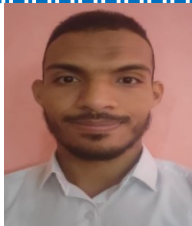

*Author is a PHD student, he has expertise in electronic field mainly in Telecommunication: antenna design (aims to design antennas devices able to support 6G technology), wireless technologies (2G, 3G, 4G, researcher in 5G and 6G).*

**Email:** [abdeddaim.rguibi@etu.uae.ac.ma](mailto:abdeddaim.rguibi@etu.uae.ac.ma)

## Study of the Seismic Performance of Construction Using Local Materials

Adil Hazzaz, Taoufik Tbatou

*Laboratory of Engineering Sciences and Biosciences (LSIB), Faculty of Science and Technology of Mohammadia*

### Abstract

This study examines the seismic performance of non-load-bearing walls constructed from stabilized earth bricks, consisting of 20% olive pomace, 40% lime, 10% fibers, and 10% cement, in the El Haouz region of Morocco, known for its seismic activity. The region experiences a seismic acceleration of approximately 0.35g. Numerical simulations were carried out to evaluate the shear stress experienced by the walls at different thicknesses when subjected to seismic forces. The results indicate that walls with a thickness of less than 35 cm experience shear stress exceeding the material's maximum resistance of 1 MPa, making them prone to cracking under such conditions. However, when the thickness is increased to 35 cm or more, the walls stay within the safe range for shear stress, ensuring their stability during seismic events. These findings underscore the importance of appropriate wall thickness for ensuring the structural integrity of buildings in seismically active areas. The study also highlights the potential of using sustainable building materials like stabilized earth bricks for seismic resilience in regions like El Haouz. This research provides practical recommendations for improving the seismic safety of structures using eco-friendly materials, contributing to the sustainable construction field.

**Keywords:** Seismic performance; Stabilized earth bricks; Shear stress; Earthquake resilience; Wall thickness; seismic acceleration



*Author has expertise in: Soil mechanics, Geotechnics, Construction materials, Structural dynamics.*

*Email: hazzazinterieur@gmail.com*



## Beam propagation and parametric characterization of vortex higher-order cosine-hyperbolic-Gaussian beams in free space

A. Ahlane, Z. Hricha, A. Belafhal

Laboratory LPNAMME, Laser Physics Group, Department of Physics, Faculty of Sciences, Chouaib Doukkali University, P.B 20, 24000 El Jadida, Morocco

### Abstract

Based on the Collins formula and the moment's method, the analytical expressions for the beam field propagation through an ABCD system, the beam propagation factor (M2-factor) and kurtosis factors of a vortex higher-order cosine-hyperbolic-Gaussian beam (vHOChGB) are derived. It is shown that the propagation characteristics are determined by the beam structure parameters, such as the decentered parameter  $b$ , the cosh order  $N$  and the topological charge  $m$ . The kurtosis parameter is dependent, besides the structure beam parameters, on the propagation distance. Numerical examples are presented to discuss the influences of the parameters  $b$ ,  $N$  and  $m$  on the propagation characteristics of vHOChGB in free space. This research may be beneficial to the applications involving vortex beams in optical communications, beam splitting, and micromanipulation of particles.

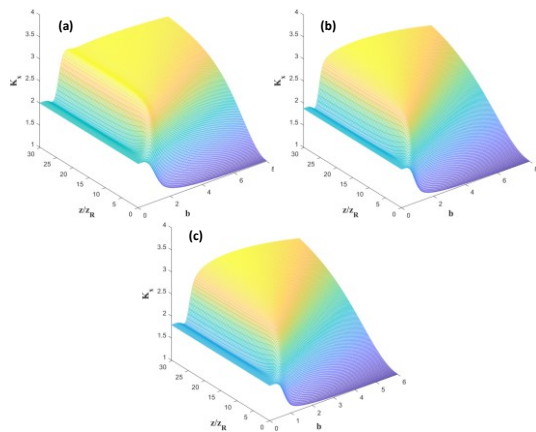

**Fig: 3D illustration of the  $K_x$  factor of a vHOChGB against the  $b$  and  $z/z_R$  parameters ( $m$  and  $N$  are taken fixed), and for (a)  $m = N = 2$ , (b)  $m = N = 3$  and (c)  $m = N = 4$ .**

### References

1. Z. Hricha, M. Yaalou, and A. Belafhal, "Introduction of a new vortex cosine-hyperbolic-Gaussian beam and the study of its propagation properties in fractional Fourier transform optical system," *Opt. Quantum Electron.*, vol. 52, no. 6, p. 296, May 2020, doi: 10.1007/s11082-020-02408-3.
2. Z. Hricha, M. Yaalou, and A. Belafhal, "Introduction of the vortex Hermite-Cosh-Gaussian beam and the analysis of its intensity pattern upon propagation," *Opt. Quantum Electron.*, vol. 53, no. 2, p. 80, Jan. 2021, doi: 10.1007/s11082-020-02665-2



*Abdellah Ahlane is a PhD student at the Faculty of Sciences, Department of Physics, University Chouaib Doukkali. His research focuses on advanced topics in laser optics. Abdellah's expertise in Lasers, Optics, Optical Physics, Laser Technology, Applied Optics and Diffraction. His work aims to contribute to the advancement of optical technologies and their applications.*

**Email:** [ahlane.abdellah@ucd.ac.ma](mailto:ahlane.abdellah@ucd.ac.ma)

ID : 70

## Introducing Robotics in High School: A Case Study with Low-Cost and 3D- Printed Robots

Mohammed El miri<sup>1</sup>, Said El khaldi<sup>1</sup>, Ismael Driouch<sup>1</sup>, Moustapha El bakkali<sup>2</sup>,  
Loukmane El khaldi<sup>3</sup>

<sup>1</sup>Abdelmalek Essaadi University, ENSAH, Experimentation and Modeling in Mechanics and Energy Systems Team, Morocco

<sup>2</sup>Abdelmalek Essaadi University, Faculty of sciences Tetouan, Morocco

<sup>3</sup>Abdelmalek Essaadi University, ENSAT, Sciences and Advanced Technologies Team, Morocco

### Abstract

In an age defined by the rapid advancement of artificial intelligence and automation, introducing robotics at the high school level is essential to inspire and prepare students for careers in engineering and technology. However, the high cost and complexity of available robotics platforms often limit their integration into schools, particularly in public institutions. This paper presents a case study that explores the use of low-cost, 3D-printed robots in a Moroccan high school, utilizing a quadruped robot and Arduino-based controller. By combining affordable hardware with 3D printing technology, students were able to design, assemble, and program their own robots, gaining practical skills in robotics and engineering. This approach not only made robotics education more accessible but also encouraged creativity and problem-solving abilities among students. The results of this case study demonstrate that with the right tools and support, low-cost robotics platforms can play a significant role in enhancing STEM education in Morocco. This paper highlights the potential for expanding such initiatives across the country, providing educators with an affordable, scalable solution to introduce robotics in schools.

**Keywords:** Low-cost robotics, Educational robots, 3d printing, STEM education.



Fig 1: Students learn CAD software based on robot models



Fig 2: Assembled 3d printed robot parts

### References

1. Screpanti, L., Miotti, B., & Moneriù, A. (2021). Robotics in education: A smart and innovative approach to the challenges of the 21st century. In *Makers at School, Educational Robotics and Innovative Learning Environments: Research and Experiences from FabLearn Italy 2019*, in the Italian Schools and Beyond (pp. 17-26). Cham: Springer International Publishing.
2. Ospennikova, E., Ershov, M., & Iljin, I. (2015). Educational robotics as an inovative educational technology. *Procedia-Social and Behavioral Sciences*, 214, 18-26.
3. Ouyang, F., & Xu, W. (2024). The effects of educational robotics in STEM education: A multilevel meta- analysis. *International Journal of STEM Education*, 11(1), 7.
4. Fang, Z., Fu, Y., & Chai, T. (2009, May). A low-cost modular robot for research and education of control systems, mechatronics and robotics. In *2009 4th IEEE Conference on Industrial Electronics and Applications* (pp. 2828-2833). IEEE.



*Mohammed El Miri is a PhD student at Abdelmalek Essaadi University, in the Experimentation and Modeling in Mechanics and Energy Systems Team, where he focuses on the development of low-cost and modular robotic platforms for educational applications. His research work is directed by Dr. Ismael Driouch and co-directed by Dr. Said El Khaldi. In addition to his research on robotics, he is passionate about teaching and mentoring students, supporting creativity and problem-solving skills in the next generation of innovators.*

**Email:** [elmi.mohamed@gmail.com](mailto:elmi.mohamed@gmail.com)

## Enhancing Photovoltaic-Thermal System Efficiency through Phase Change Materials and Fins: A CFD Simulation Study

Fatima Ouerradi<sup>1</sup>, Yassine El Alami<sup>1</sup>, Abdellah Idrissi<sup>2</sup>, Rachid Bendaoud<sup>1,3</sup>, ElhadiBaghaz<sup>1</sup>

<sup>1</sup>Laboratory of Electronics, Instrumentation and Energetic, Faculty of Sciences, Chouaib Doukkali University, B.P 20, El Jadida, Morocco

<sup>2</sup>Laboratory of Energy Engineering and Materials, FST Sultan Moulay Slimane University, Beni Mellal, Morocco

<sup>3</sup>Interdisciplinary Laboratory for Research in Science, Education, and Training, Higher School of Education and Training-Berrechid, Hassan First University, Berrechid, Morocco

### Abstract

As the energy transition gathers pace, improving the efficiency of renewable technologies becomes crucial. Photovoltaic panels, which exploit the photoelectric effect of silicon to generate electricity, currently reach a maximum efficiency of around 22%, limited by rising panel temperatures. Photovoltaic-thermal hybrid (PVT) systems, which combine photovoltaic cells and thermal collectors, offer a promising solution by using a water circuit to absorb heat and maintain panel temperature close to its nominal range, thus optimizing electrical efficiency. However, further improvements can be made by integrating phase-change materials (PCMs) and fins to enhance heat transfer. This study examines the benefits of incorporating PCMs, in particular organic PCM RT35 with a melting point of 35°C and latent heat capacity of 210 kJ/kg, and rectangular fins in a PVT configuration. Two simulations are carried out in ANSYS Fluent: the first to assess the impact of PCMs on temperature control and system efficiency, and the second to analyze the additional benefits provided by the fins. The results are intended to quantify improvements in energy efficiency and system performance, providing insight into advanced PVT design strategies.



*Fatima Ouerradi was born in 1995 in Sidi Bennour, Morocco. She has followed an impressive academic path, starting with her Bachelor's degree in Experimental Sciences in 2013. In 2016, she earned her Licence Sciences de la Matière Physique, with a specialization in Physics and an option in renewable energy exploitation, from the Faculty of Sciences at the Chouaib Doukkali University in El Jadida. In 2018, Fatima continued with a Master's degree in the same faculty. In 2023, she began a new chapter by becoming a PhD student at the Chouaib Doukkali University, in the Electronics, Instrumentation and Energetics (LEIE) program. Her research focuses on the characterization and experimental simulation of photovoltaic-thermal (PVT) hybrid generators using phase-change materials (PCM).*

*Email: [ouerradi.fatima@ucd.ac.ma](mailto:ouerradi.fatima@ucd.ac.ma)*

## Maintenance 4.0: Integrating Non-Destructive Testing and Vibration Analysis for Predictive Maintenance

Soufiane EMBARKI<sup>1</sup>, Ali EL KIHHEL<sup>2</sup>

<sup>1-2</sup>Laboratory of Industrial Engineering and Seismic Engineering, UMP Oujda, Oujda, Morocco

### Abstract

Maintenance 4.0 represents the integration of advanced digital technologies to revolutionize industrial maintenance practices. It leverages data-driven tools, such as predictive analytics and real-time monitoring, to optimize maintenance operations, reduce downtime, and extend the life of critical assets. In this context, non-destructive testing (NDT) techniques, particularly vibration analysis, play a crucial role in enhancing predictive maintenance strategies. Vibration analysis, as a part of condition monitoring, allows for the early detection of faults in rotating machinery by analyzing oscillation patterns and identifying deviations from normal operating conditions. This method provides invaluable insights into the health of equipment without interrupting production processes.

The fusion of NDT methods with Industry 4.0 technologies, such as the Industrial Internet of Things (IIoT) and artificial intelligence (AI), enables the creation of digital twins and predictive maintenance frameworks. These systems continuously collect and analyze data from sensors embedded in machines, allowing for precise fault prediction and proactive maintenance scheduling. This paper explores the synergy between Maintenance 4.0 and vibration-based NDT techniques, highlighting their potential to reduce unplanned downtime, enhance safety, and improve operational efficiency in industrial environments. Case studies of industrial applications will be discussed to demonstrate the effectiveness of this approach in real-world scenarios.

**Keywords:** Maintenance 4.0; Vibration Analysis; Non-Destructive Testing; Predictive Maintenance; IIoT

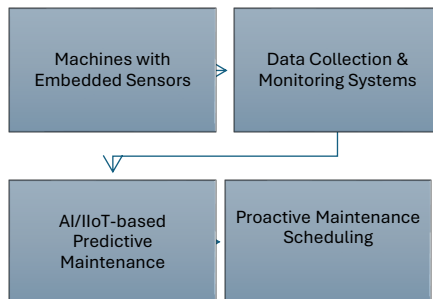

**Fig: Maintenance 4.0 framework integrating non-destructive testing (NDT) and vibration analysis.**

### References

1. Singh, A., Gupta, N., & Kaur, M. (2022). Vibration-based condition monitoring in predictive maintenance: A comprehensive review. *Journal of Industrial Engineering and Management*, 15(3), 315-328.
2. Johnson, L., & Patel, S. (2021). Enhancing predictive maintenance with non-destructive testing and AI integration. *Smart Maintenance Technologies*, 9(4), 47-58.
3. Müller, H., & Weiss, P. (2023). The role of digital twins in the next generation of maintenance strategies. *International Journal of Maintenance Science*, 12(1), 25-39.
4. Zhang, Y., & Tan, J. (2021). The impact of Industry 4.0 on predictive maintenance: A review. *Journal of Manufacturing Systems*, 60, 330-342.
5. García Márquez, F. P., & Schmid, F. (2022). A machine learning approach to predictive maintenance based on NDT. *Applied Sciences*, 12(5), 2194.
6. Li, X., & Gao, H. (2023). Digital twins and NDT in predictive maintenance for Industry 4.0. *IEEE Transactions on Automation Science and Engineering*, 20(3), 1234-1245.



*Soufiane EMBARKI has expertise in predictive maintenance, industrial automation, and the integration of non-destructive testing (NDT) techniques, particularly vibration analysis, within Maintenance 4.0 frameworks. Their research focuses on leveraging artificial intelligence (AI) and the Industrial Internet of Things (IIoT) to enhance maintenance strategies in various industrial sectors, with a particular interest in the application of digital twins for operational efficiency.*

**Email:** [S.embarki@ump.ac.ma](mailto:S.embarki@ump.ac.ma)

## Numerical modeling of the propagation of a reflective crack within the asphalt layers of a pavement under traffic

Ayoub M'chich, Khalid Nasri

Laboratory of Industrial and Civil Sciences and Technologies, ENSATE, Abdelmalek Essaadi University, Tetouan, Morocco

### Abstract

Road pavements are subjected to considerable cyclic traffic loads, which result in the propagation of cracks, especially in the vicinity of existing discontinuities. These cracks can ultimately evolve into various forms of road deterioration. To acquire a comprehensive understanding of the lifespan of roads in relation to crack propagation during both the design and maintenance phases, it is essential to thoroughly investigate the behavior of cracks within the pavement layers. Consequently, a significant body of research has been dedicated to this critical subject.

The aim of this study is to investigate the propagation behavior of a reflective crack originating from the base of the first bituminous layer and advancing through the asphalt layers of a pavement under the influence of traffic loading. This analysis employs the principles of fracture mechanics, utilizing finite element analysis as its methodological framework.

The study presents a three-dimensional model created using Abaqus software, depicting a four-layer pavement that incorporates a pre-existing longitudinal crack located at the base of the first bituminous layer, which is expected to propagate upward through the asphalt layers. The pavement structure comprises a surface layer, a base layer, a sub-base layer, and a sub-grade layer. The first two layers on the top are constructed from bituminous materials, the third from untreated aggregate, and the final layer consists of soil. All materials are assumed to exhibit linear elastic behavior, with the structure subjected to loading from a pair of wheels. Subsequently, numerical calculations of the J-integrals and the stress intensity factors  $K_I$ ,  $K_{II}$  and  $K_{III}$  were conducted, taking into account varying lengths and positions of the crack tip in relation to the interfaces between layers.

Several conclusions have been reached that offer insights into the behavior of crack propagation within the pavement structure, which can prove practically beneficial during the road design and maintenance process.

### References

1. H. Akbulut, K. Aslantas / Materials and Design 26 (2005) 383–387.
2. Jorge Garzon — Carlos Armando Duarte — William Buttlar, Road Materials and Pavement Design. Volume 11- No. 2/2010.
3. Jia Zhang, Dandan Cao, Jinxi Zhang, construction and building Materials 367 (2023) 130306.
4. M. Ameri et al. Engineering fracture mechanics 78 (2011) 107736.
5. M R M, Aliha, M.J. Sarbijan / Engineering Fracture Mechanics xxx (2016) xxx-xxx.



*Author has expertise in the programming, monitoring and control of road works, oversight of road project studies, and coordination among the various stakeholders in road projects, currently a relevant doctoral student from ENSATE-ABDELMALEK ESSADI University, Tetouan, Morocco*

**Email:** ayoub.mchich1@etu.uae.ac.ma



## Parametric study of mat-foundation system under dynamic seismic loading accounting local uplift, soil behavior and magnitude of rotation

Nadia El abbas<sup>1, 2</sup> Khamlichi Abdellatif<sup>3</sup> and Mohammed Bezzazi<sup>4</sup>

<sup>1</sup>Laboratory of Electromagnetism, Plasma Physics and Applications, Higher School of Technology, Nador, Morocco

<sup>2</sup>Laboratory of Applied Sciences Research "LARSA", National School of Applied Sciences, Oujda, Morocco

<sup>3</sup>Department Sciences et Technologies Industrielles et Civiles, National School of Applied Sciences, Tetouan, Morocco

<sup>4</sup>Department of Physics, Faculty of Science and Technology, Tangier, Morocco

### Abstract

This study was dedicated to the analysis of the effect of rotations for a mat-foundation system under dynamic seismic loading. The structure was assumed to be a flexible mat having one degree of freedom and which is anchored on a rigid base supported by the foundation soil. The analysis has taken into account both local uplift of the foundation and elastic-plastic behavior of the soil. The equations of motion of the coupled system were obtained by expressing momentum conservation principle. They are strongly nonlinear due to the occurrence of unilateral contact associated to local uplift of the base foundation and the soil elastic-plastic deformation. A numerical scheme was proposed in order to integrate the obtained multiform nonlinear differential equations. Then, the maximum response of the coupled system was determined under strong earthquake for various configurations of the coupled mat-foundation system: elastic or elastic-perfectly plastic soil, considering large rotations or only small rotations. The obtained results have shown that the maximum values of rotation and horizontal displacement of the mat are not always restrained by taking into account soil plasticity. This depends on the assumption used regarding the magnitude of rotation and soil behavior, particularly for the case of slender structures.

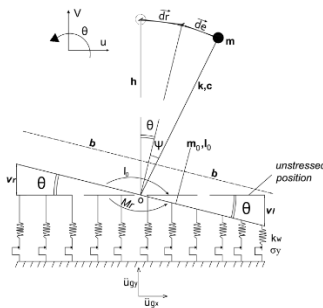

**Fig: Flexible structure on elastic-perfectly plastic foundation**

### References

- 1.G. Gazetas, Seismic design of foundations and soil structure interaction, Proceedings, First European Conference on Earthquake Engineering and Seismology, Geneva, Switzerland, 2006.
- 2.A.K Chopra, C.S. Yim, Simplified earthquake analysis of structures with foundation uplift, Structural Engineering ASCE 111(1985) 906-930.
- 3.X.C. Chen, Y.M. Lai, Seismic response of bridge piers on elasto-plastic Winkler foundation allowed to uplift, Sound and Vibration 266 (2003) 957-965.
- 4.C.Yue, Bo, C. Weizhen, Elasto-Plastic Seismic Response of RC Continuous Bridge with Foundation-Pier Dynamic, Interaction Advances in Structural Engineering 18 (2015).
- 5.N. El Abbas, A. Khamlichi, and M. Bezzazi, Seismic response of foundation-mat structure subjected to local uplift, Coupled System Mechanics 4 (2016)285-304.



Author has expertise in the field of Civil Engineering, I develop research activities in the theme of Seismic Soil-Structure Interaction. Professor of higher education at the Higher School of Technology of Nador, Mohamed Premier University

Email: na.elabbas@ump.ac.ma

## Photovoltaic thermal systems based on phase-change materials: analysis of advances and optimization techniques

Fatima Ouerradi<sup>1</sup>, Yassine El Alami<sup>1</sup>, Rachid Bendaoud<sup>1,2</sup>, Abdelhamid Rabhi<sup>3</sup>, Elhadi Baghaz<sup>1</sup>

<sup>1</sup>Laboratory of Electronics, Instrumentation and Energetic, Faculty of Sciences, Chouaib Doukkali University, B.P 20, El Jadida, Morocco;

<sup>2</sup>Interdisciplinary Laboratory for Research in Science, Education, and Training, Higher School of Education and Training-Berrechid, Hassan First University, Berrechid, Morocco;

<sup>3</sup>Laboratory of Modulization, Information and Systems, University of Picardie Jules Verne, Amiens, France.

### Abstract

Photovoltaics offers an advanced solution for replacing fossil fuels in electricity generation. However, this technology can only convert around 20% of the sun's energy into electricity, while the rest is dissipated in the form of heat. This heat build-up causes the temperature of the panels to rise, which has a negative impact on their efficiency and reduces their lifespan. Faced with this challenge, particularly in hot regions, researchers have focused on cooling methods to improve the efficiency of solar panels. Among the solutions studied, the use of phase change materials (PCMs) has emerged as a promising approach for regulating the temperature of photovoltaic systems. This paper reviews advances in the use of PCMs for photovoltaic thermal systems (PVT-PCM). It looks at the development and configuration of these systems, the evaluation of their performance, and the choice of the most appropriate materials. The paper also explores techniques for optimizing heat transfer, such as the use of nano-enhanced PCMs, the addition of fins, and the integration of microencapsulated or multilayer PCMs. In addition, a classification of PCMs is provided, with a detailed description of their characteristics. In conclusion, recommendations are made to guide future research aimed at improving the performance and feasibility of PVT-PCM systems.



*Fatima Ouerradi was born in 1995 in Sidi Bennour, Morocco. She has followed an impressive academic path, starting with her Bachelor's degree in Experimental Sciences in 2013. In 2016, she earned her Licence en Sciences de la Matière Physique, with a specialization in Physics and an option in renewable energy exploitation, from the Faculty of Sciences at the Université Chouaib Doukkali in El Jadida. In 2018, Fatima continued with a Master's degree in the same faculty. In 2023, she began a new chapter by becoming a PhD student at the Université Chouaib Doukkali, in the Electronics, Instrumentation and Energetics (LEIE) program. Her research focuses on the characterization and experimental simulation of photovoltaic-thermal (PVT) hybrid generators using phase-change materials (PCM).*

**Email:** [ouerradi.fatima@ucd.ac.ma](mailto:ouerradi.fatima@ucd.ac.ma)

## Extraction of optimal parameters from a Flexible Photovoltaic Cell using Monte Carlo optimization and parallel resistance adjustment

Fatima Wardi<sup>1</sup>, Mohamed Louzazni<sup>2</sup>, and Mohamed Hanine<sup>3</sup>

<sup>1</sup>Science Engineer Laboratory for Energy, National School of Applied Sciences, Chouaib Doukkali University of El jadida, Morocco ; <sup>2</sup> information technology laboratory, National School of Applied Sciences, Chouaib Doukkali University of El jadida, Morocco ; – Morocco

<sup>2</sup>Science Engineer Laboratory for Energy, National School of Applied Sciences, Chouaib Doukkali University of El Jadida, El Jadida P.O. Box 20, Morocco – Morocco

<sup>3</sup>Department of Telecommunications, Networks, and Informatics, LTI Laboratory, ENSA, Chouaib Doukkali University, El jadida 24000 – Morocco

### Abstract

This paper studies flexible solar cells and amorphous silicon (a-Si:H) hydrogen, which are ideal for disposable portable electronics and more flexible smart devices. Because the film production is less efficient than other technologies, it offers more advanced economics. The innovation of this paper lies in an advanced simulation of a flexible solar cell, using Monte Carlo optimization and parallel resistance adjustment. This method is used to determine the optimal model parameters in order to reduce the discrepancies between photovoltaic model predictions and experimental data by adjusting the model parameters. The paper meets the advantages of this approach, such as the ability of more complex, nonlinear models and spatial screening of parameters to find optimal solutions.

**Keywords:** Solar Cell, Flexible Photovoltaic Cell, Monte Carlo optimization, parallel resistance adjustment



Email : [fatimawarda1997@gmail.com](mailto:fatimawarda1997@gmail.com)

---

## Evaluation of the Seismic Response of RC Buildings considering different heights, uplifting, soil properties and seismicity of area

Nadia El abbas<sup>1,2</sup>, Khamlichi Abdellatif<sup>3</sup> and Mohammed Bezzazi<sup>4</sup>

<sup>1</sup>Laboratory of Electromagnetism, Plasma Physics and Applications, Higher School of Technology, Nador, Morocco

<sup>2</sup>Laboratory of Applied Sciences Research "LARSA", National School of Applied Sciences, Oujda, Morocco

<sup>3</sup>Department Sciences et Technologies Industrielles et Civiles, National School of Applied Sciences, Tetouan, Morocco

<sup>4</sup>Department of Physics, Faculty of Science and Technology, Tangier, Morocco

### Abstract

This work presents an evaluation of different height of reinforced concrete buildings to scaled ground-motion taking into account local uplift of foundation, soil properties, site categories and seismicity of area recommended by the Moroccan seismic code RPS2011. The RC building was modeled by equivalent flexible column with lumped mass placed at the top of the column. Small and large rotation about the system base motion is both taken into account. The analysis has considered into account a local uplift of foundation and elastic-plastic behavior of the soil in different site categories and seismicity of area. The equations of motion of the coupled system were obtained by expressing momentum conservation principle. They are highly nonlinear due to continuous change in change in the contact area associated to local uplift between the base foundation mat and soil elastic-plastic deformation. The governing equations can be solved by an adequate numerical integration method. Then, the extreme seismic response of the coupled system was determined under El Centro earthquake motion for various configurations of the coupled mat-foundation system: elastic or elastic-perfectly plastic soil in different site categories and seismicity of area suggested by the Moroccan code RPS2011, considering large rotations or only small rotations. This study shows that the nonlinear seismic demand of RC buildings, in terms of extreme values of rotation and horizontal or vertical displacements are appreciably depending on the adopted assumption for rotation magnitude, height of the structure and on the hypothesis regarding soil deformation

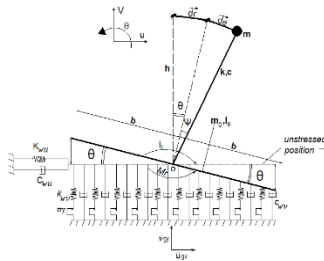

**Fig: Flexible structure on elastic-perfectly plastic foundation**

### References

1. I. N. Psycharis, Int. J. Rock Mech. Min. Sc. Geomech., 11, 501-521 (1983)
2. I. N. Psycharis, P. C. Jennings, Earthq. Engrg. Struct. Dyn., 11, 57-76 (1984)
3. Y.H. Song, D.G. Lee, Computers & Structures 46, 5 (1993)
4. S. T. Karapetrou, S. D. Fotopoulou, K. D. Pitilakis, Soil Dyn. Earthq. Engrg., 73, 42-57 (2015)
5. N. El Abbas, A. Khamlichi, M. Bezzazi, MATEC Web Conf. 83, 09006 (2016)
6. Ministry of Housing, Urban and Spatial Planning, Morocco, RPS 2000 (2011 version)
7. G. Gazetas, J. Geot. Engrg., 117, 1363-1381 (1991) M.K. Akin, S.L. Kramer, T. Topal, Engrg. Geology, 119, 1-17 (2011)
8. N. El Abbas, A. Khamlichi, M. Bezzazi, Coupled Syst. Mech., 5, 285-304 (2017)



Author has expertise in the field of Civil Engineering, I develop research activities in the theme of Seismic Soil-Structure Interaction. Professor of higher education at the Higher School of Technology of Nador, Mohamed Premier University.

Email: na.elabbas@ump.ac.ma

## Development of a Dynamic Energy Management and Maintenance System for Thermal Systems Based on New Technologies: A Case Study on a Boiler

Bouyahrouzi El Mahdi<sup>1</sup>, El Kihel Ali<sup>2</sup>, Sehli Lotfi<sup>3</sup>, Berquedich Mouna<sup>4</sup>

<sup>1</sup> Industrial Engineering Laboratory, National School of Applied Sciences, Mohammed First University, Oujda, Morocco

<sup>2</sup> Industrial Engineering Laboratory, National School of Applied Sciences, Mohammed First University, Oujda, Morocco

<sup>3</sup> Industrial Engineering Laboratory, National School of Applied Sciences, Mohammed First University, Oujda, Morocco

<sup>4</sup> Green Tech Institute- Mohammed VI Polytechnique University, Benguerir, Morocco

### Abstract

Global competition in the manufacturing sector is intensifying, pushing companies toward constant innovation. As this competition grows, industrial systems and production machinery are becoming increasingly complex. In this context, rigorous maintenance planning is crucial to ensure optimal equipment availability and production tool longevity, while also improving product quality and overall plant productivity. However, while conventional maintenance and traditional servicing methods have proven effective over time, they are now becoming inadequate in addressing the increasing complexity of modern industrial systems. The advent of digital technologies, particularly IoT sensors, opens new opportunities by enabling the continuous collection of precise data on the operational status of equipment. Once analyzed, this data generates large databases that are invaluable for optimizing maintenance strategies. To address this technological shift, this study presents an enhanced approach to the application of Maintenance 4.0 in thermal systems. A comprehensive transition to 4.0 maintenance, based on the integration of new technologies, has been developed, refined, and applied. This approach leads to improved equipment reliability and lifespan, a reduction in unplanned downtime, real-time monitoring of industrial systems, the ability to predict future system states, and optimization of key input variables, such as fuel oil flow and boiler temperature, to achieve maximum efficiency with minimal inputs. The results demonstrate a significant reduction in maintenance costs, estimated at around 20%, along with an increase in boiler efficiency to 81%. Additionally, the overall Synthetic Efficiency Ratio (SER) improved by 2%, reaching 82.58%. This innovative approach opens new perspectives for the maintenance of industrial thermal systems, promoting more efficient and sustainable production practices.

### References

1. Y. El kihel, A. El kihel, and E. M. Bouyahrouzi, "Contribution of Maintenance 4.0 in Sustainable Development with an Industrial Case Study," *Sustainability*, vol. 14, no. 17, Art. no. 17, Jan. 2022, doi: 10.3390/su141711090.
2. M. Alarcón, F. M. Martínez-García, and F. C. Gómez de León Hijes, "Energy and maintenance management systems in the context of industry 4.0. Implementation in a real case," *Renewable and Sustainable Energy Reviews*, vol. 142, p. 110841, May 2021, doi: 10.1016/j.rser.2021.110841.
3. J. Zhang, Y. Wang, Y. Yang, Y. Ma, and Z. Dai, "Fault diagnosis and intelligent maintenance of industry 4.0 power system based on internet of things technology and thermal energy optimization," *Thermal Science and Engineering Progress*, vol. 55, p. 102902, Oct. 2024, doi: 10.1016/j.tsep.2024.102902.
4. J. Dalzochio et al., "Machine learning and reasoning for predictive maintenance in Industry 4.0: Current status and challenges," *Computers in Industry*, vol. 123, p. 103298, Dec. 2020, doi: 10.1016/j.compind.2020.103298.
5. N. Firdaus, H. Abdul Samat, and N. Mohamad, "Maintenance for Energy efficiency: A Review," *IOP Conference Series: Materials Science and Engineering*, vol. 530, p. 012047, Jul. 2019, doi: 10.1088/1757-899X/530/1/012047



**BOUYAHROUZI El Mahdi's** academic journey began in 2018 when he earned a B.Eng. degree in Industrial Electronics and Computer Engineering from the Faculty of Pluridisciplinary Studies, University of Mohammed First, Nador. He continued his educational pursuits by obtaining an M.Eng. in Smart Industry from the Faculty of Sciences, University of Sidi Mohamed Ben Abdellah, Fez, Morocco, in 2020. Finally, he earned a Ph.D. in Industrial Engineering, focusing on Predictive Maintenance, Digital Transformation, and Industry 4.0 from the National School of Applied Sciences, University of Mohammed First, Oujda, Morocco. His areas of research expertise encompass a wide range of topics, including the Internet of Things, Predictive Maintenance, Artificial Intelligence, machine learning applications in manufacturing, supply chain optimization, and automation technologies. He is dedicated to advancing the field of industrial engineering through innovative research and practical solutions. For inquiries or contact, you can reach him at the following email address:

**Email:** [elmahdi.bouyahrouzi@ump.ac.ma](mailto:elmahdi.bouyahrouzi@ump.ac.ma)



## Optimization of Energy Consumption in the PET Bottle Blowing Process

Lotfi Sehli<sup>1</sup>, Yousra Elkihel<sup>2</sup>, El Mahdi Bouyahrouzi<sup>1</sup>, Bachir elkihel<sup>1</sup>

<sup>1</sup> Equipe de Génie Industriel ENSA OUJDA MAROC

<sup>2</sup> Laboratoire LINEACT CESI Bordeaux France

### Abstract

Energy management in industrial companies helps reduce operational costs, comply with environmental regulations, and maintain long-term competitiveness. The process of manufacturing PET (polyethylene terephthalate) bottles from preforms, which are heated and then blown at high pressure, is energy intensive. Achieving a balance between blowing pressure and preform heating temperature is critical to producing bottles with the desired mechanical and geometric characteristics while reducing energy costs. By optimizing the preform heating temperature, it is possible to lower the blowing pressure and achieve overall energy savings. The use of online energy meters on the machines has enabled tests that helped reduce overall energy consumption on the blow molding machine.

### References

1. V. Jovanovic, B. Stevanov, D. Šešlija, S. Dudić, Z. Tešić. "Energy efficiency optimization of air supply system in a water bottle manufacturing system". Journal of Cleaner Production. 85, (2014), pp. 306-317.
2. K.S. Sangwan. Performance Value Analysis for Justification of Green Manufacturing Systems. J. Adv. Manuf. Syst., 5 (1) (2006), pp. 59-73
3. G. Liguori, "Industry 4.0. The evolution of Maintenance Strategy".
4. Y. Lu, "Industry 4.0: A survey on technologies, applications and open research issues".
5. S. Ge-Zhang, H. Liu, M. Song. Advances in Polyethylene Terephthalate Beverage Bottle Optimization: A Mini Review. Polymers, 14(16), (2022), pp. 3364.



*Author has expertise in industrial management, with a specialization in Production, Maintenance, Quality and Safety. As an Electromechanical Engineer, he has gained extensive experience in industrial projects, Optimization of production processes and Energy Management. Currently a PhD candidate in Maintenance 4.0, his research focuses on strategies for implementing maintenance 4.0 in SMEs.*

**Email:** l.sehli@ump.ac.ma

ID :129

## Impact of Manufacturing Execution Systems on Maintenance in the context of Industry 4.0: Case study

Lotfi Sehli, Ali Elkihel, Soufiane Embarki, Bachir elkihel

Equipe de Génie Industriel ENSA OUJDA MAROC

### Abstract

Manufacturing Execution Systems (MES) have a significant influence on maintenance by collecting real-time information on machinery performance, enabling predictive maintenance, and optimizing maintenance schedules. The MES enhances traceability and the ability to learn from past maintenance events and to continuously improve practices. The MES allows using data from it to predict breakdowns and improve maintenance effectiveness and efficiency. A case study shows the improvements of maintenance due to integration of MES in a manufacturing facility. It resulted in a significant decrease in unplanned downtime, as well as an increase in overall equipment effectiveness. Moreover, it enabled the facility to shift from reactive maintenance to a proactive approach minimizing disruptions to production. The case study shows the impact of MES on maintenance and its ability to elevate overall manufacturing performance.

### References

1. M. Younus, P. Cong, L. Hu and Y. Fan. "MES development and significant applications in manufacturing -A review". Jun. 2010. 10.1109/icetc.2010.5530040.
2. C. F. "Predictive maintenance in the Industry 4.0: A systematic literature review".
3. "Maintenance transformation through Industry 4.0 technologies: A systematic literature review".
4. G. Liguori, "Industry 4.0. The evolution of Maintenance Strategy".
5. I. Roda, M. Macchi and L. Fumagalli, "The Future of Maintenance Within Industry 4.0: An Empirical Research in Manufacturing".
6. Y. Lu, "Industry 4.0: A survey on technologies, applications and open research issues".
7. "Lean Maintenance 4.0: An application of the IoT Technology in the facility management industry".
8. R. Y. Zhong, X. Xu, E. Klotz and S. T. Newman, "Intelligent Manufacturing in the Context of Industry 4.0: A Review"



*Author has expertise in industrial management, with a specialization in Production, Maintenance, Quality and Safety. As an Electromechanical Engineer, he has gained extensive experience in industrial projects, Optimization of production processes and Energy Management. Currently a PhD candidate in Maintenance 4.0, his research focuses on strategies for implementing maintenance 4.0 in SMEs.*

**Email:** [l.sehli@ump.ac.ma](mailto:l.sehli@ump.ac.ma)

## Enhanced Monitoring and Fault Detection in Rotating Machinery: A Maintenance 4.0 Approach Leveraging Real-Time Vibration Analysis

Ali EL KIHHEL<sup>1</sup>, Soufiane EMBARKI<sup>1</sup>

<sup>1</sup>Laboratory of Industrial Engineering and Seismic Engineering, National School of Applied Sciences ENSA Oujda, Mohammed Premier University, Oujda, Morocco

### Abstract

In the era of Industry 4.0, Maintenance 4.0 has emerged as a crucial technological advancement aimed at enhancing machine reliability and operational efficiency through real-time data analysis. This paper presents the development of an advanced monitoring system for rotating machinery, focusing on unbalance and misalignment detection. A novel algorithm utilizing the Fast Fourier Transform (FFT), implemented in Python, is employed for vibration analysis based on ISO 10816 standards. The system's architecture includes a real-time data acquisition module that collects and processes vibration signals through strategically placed accelerometers. The collected data is analyzed to identify early signs of unbalance and misalignment, allowing for timely intervention. Experimental validation was conducted on a test bench, where the method successfully differentiated between normal and faulty motor conditions, showing a marked increase in vibration levels during fault occurrences. This approach not only ensures the automatic detection and diagnosis of machine faults but also provides an efficient solution for predictive maintenance. The research contributes to extending machine lifespan, reducing operational costs, and minimizing downtime by providing a robust and scalable monitoring framework suitable for Maintenance 4.0 environments. Future work aims to integrate digital twins to enhance fault prediction and operational simulations, further improving machine reliability and maintenance decision-making.

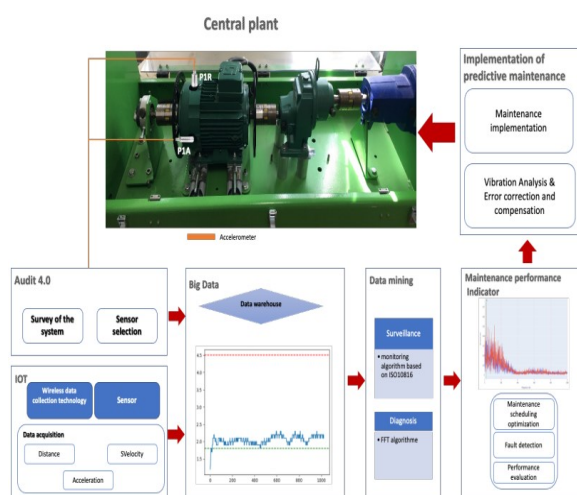

### References

1. Z. Li, K. Wang, and Y. He, "Industry 4.0 - Potentials for Predictive Maintenance," presented at the 6th International Workshop of Advanced Manufacturing and Automation.
2. M. X. Chiementin and M. L. Rasolofondraibe, "Contribution au processus de surveillance intelligente des machines tournantes : cas des roulements à billes. Thèse dirigée par Xavier Chiementin et Lantorasolofondraibe," p. 137.
3. A. EL KIHHEL, and El. Bouyahrouzi, and Ali, "Optimizing Energy Generation: Real-Time Performance Management Strategy Leveraging 4.0 Technologies in the Energy 4.0 Era," presented at Conference: 2023 7th IEEE Congress on Information Science and Technology (CiSt).
4. El. Bouyahrouzi, and B. EL KIHHEL, "Development of a new monitoring method for rotating machines based on Maintenance 4.0, a case study of unbalance and misalignment.



Author has expertise in Industry 4.0 and advanced maintenance technologies, with a specific focus on integrating artificial intelligence for predictive maintenance and energy optimization. Mr. Ali EL KIHHEL is a professor at the Ecole Supérieure de Technologie de Nador, affiliated with Mohammed Premier University in Oujda, Morocco. His research interests center on integrating Artificial Intelligence (AI) and the Internet of Things (IoT) into predictive maintenance strategies for Industry 4.0 applications. He specializes in the development of intelligent systems that monitor and diagnose faults in industrial machinery, with an emphasis on real-time performance management and energy optimization.

Additionally, Mr. EL KIHHEL has contributed to the fields of warehouse logistics and continuous improvement, with a focus on optimizing operational processes. His work in the automotive and food industries demonstrates the application of Lean 4.0 tools to reduce waste and improve energy consumption. His expertise extends to energy audits, thermography, and the development of sustainable distribution supply chains, further highlighting his contribution to both industrial efficiency and sustainability.

Email: [a.elkihel@ump.ac.ma](mailto:a.elkihel@ump.ac.ma)

ID :137

## Enhancing Supply Chain Resilience Through Digital Technologies with a Case Study

Yousra EL KIHHEL<sup>1</sup>, Soufiane EMBARKI<sup>2</sup>, Bachir EL KIHHEL<sup>2</sup>

<sup>1</sup> CESI Engineering School - LINEACT, France

<sup>2</sup> Applied Sciences Research Laboratory, National School of Applied Sciences, Oujda, Morocco

### Abstract

Numerous global issues are causing disruptions to supply chains (SC's), including health problems, conflicts, staff shortages, inventory scarcity and political uncertainty...In response to these challenges, this research work aims to present a conceptual framework that explains the relationship between 4.0 technologies and SC Resilience. We answer the following question:

“To what extent do new technologies contribute to strengthening the links in the SC and its resilience in the face of risk? In other words, the ability to avoid most supply chain disruptions and mitigate the consequences of those that do occur. Operational risks and service interruptions can threaten the SC at various points, and ultimately jeopardize the resilience of the entire enterprise. To be truly resilient, a SC must be able to anticipate and, in many cases, avoid disruptions. To achieve this, the most resilient and agile SC's must be designed to integrate new technologies, to do more than simply resist, and enable them to foresee, anticipate and react rapidly to future risks or opportunities.

To do this, we first define the concept of resilience (presented in various fields), then show how the integration of I4.0 digital technologies can fundamentally change SC management, acting as a catalyst for a more effective response to disruptions. The results obtained for a food SC will help to improve business performance and ensure a reliable, SC resilience

### References

1. M.Holgado, C.Blome, M.C.Schleper, & N.Subramanian. "Brilliance in resilience: operations and supply chain management's role in achieving a sustainable future". International Journal of Operations & Production Management, 44(5), 877-899, (2024).
2. Liu, Z., Costa, C., & Wu, Y. (2024). Data-Driven Optimization of Production Efficiency and Resilience in Global Supply Chains.
3. Ivanov, D. (2023). Intelligent digital twin (iDT) for supply chain stress-testing, resilience, and viability. International Journal of Production Economics, 263, 108938.



*Author has expertise in industrial management, process modeling and simulation and the digitization of SC. She is got her PhD in Production at IMS-University of Bordeaux, France in 2021. She is an Industrial Engineering optionlogistic. Currently, she is Associate Professor at CESI LINEACT of Bordeaux. Her research domain includes SupplyChain Management, the digital transformation of industrial processes using the digital twin*

**Email:** yelkihel@cesi.fr

ID : 149

## Integrating Renewable Energy Education in High Schools: Empowering the Next Generation for Sustainable Development

Brahim BELMAHDI<sup>1</sup>, Mohamed LOUZAZNI<sup>2</sup>

<sup>1</sup>Energetics Laboratory, ETEE, Faculty of Sciences, Abdelmalek Essaadi University, Tetouan, Morocco

<sup>2</sup>Science Engineer Laboratory for Energy, National School of Applied Sciences, Chouaib Doukkali University, El Jadida, Morocco

### Abstract

The increasing urgency to address climate change and transition to sustainable energy systems calls for greater educational focus on renewable energy, especially at the high school level. This study examines the integration of renewable energy topics into high school curricula to raise awareness, build knowledge, and develop critical skills for a sustainable future. Through an interdisciplinary approach, students can explore the principles, technologies, and real-world applications of renewable energy sources such as solar, wind, hydro, and bioenergy. The research assesses the impacts of renewable energy education on student engagement, environmental awareness, and motivation toward STEM (science, technology, engineering, and mathematics) fields. Findings highlight that introducing renewable energy education at an early age fosters environmental responsibility, prepares students for green career pathways, and promotes community engagement. This paper advocates for curriculum development, teacher training, and resource allocation to ensure effective renewable energy education, positioning young people as active participants in the global shift toward sustainability.

**Keywords:** climate change; sustainable energy systems; renewable energy education; high school curricula; interdisciplinary approach



*His research interests include solar radiation forecasting, artificial intelligence, neural networks, optimization, machine learning optimization algorithms, hybrid models, solar combined systems, building, and engineering.*

**Email:** [belmahdi.brahim@gmail.com](mailto:belmahdi.brahim@gmail.com)

---



ID : 153

## Experimental study on failed reverse osmosis membrane at the end of life stage

Fadwa Jouali, Fatima Majid

*Laboratory of Nuclear, Atomic, Molecular, Mechanical and Energetic Physics, Chouaib Doukkali University, El jadida, – Morocco***Abstract**

The performance and durability of membrane materials are critical in seawater desalination process. This study investigates the aging mechanisms of a polymeric membrane that has reached the end of its operational life. We employed a combination of accelerated aging tests and real-time monitoring to assess changes in physical and chemical properties over time. Key parameters such as permeability, selectivity, and mechanical integrity were evaluated before and after exposure to harsh operational conditions.

The results indicate significant alterations in membrane structure, with increased pore size and reduced selectivity correlating with extended usage. Understanding these aging mechanisms provides insights into the development of more robust membrane materials and informs lifecycle management strategies for membrane-based systems.

**Keywords:** Membrane, desalination, mechanical characterization.



ID : 159

## Monte Carlo simulation of the magnetic properties of a multilayer mixed-spin system (5/2, 3/2)

H. Saadi<sup>1</sup>, A. Al-Rajhi<sup>2</sup>, E.M. Jalal<sup>1,3</sup>, and M. El Bouziani<sup>1</sup>

<sup>1</sup>Theoretical Physics Team, Laboratory L.P.M.C., Faculty of Sciences, Chouaib Doukkali University, El Jadida, Morocco

<sup>2</sup>Department of Information Technologies, Faculty of Education and Applied Sciences, Hodeidah, University, Raymah, Yemen...

<sup>3</sup>LS2ME Laboratory, Polydisciplinary Faculty of Khouribga, Sultan Moulay Slimane University, BeniMellal, Morocco

### Abstract

A Monte Carlo simulation has been employed to investigate the critical behavior of a multilayer system composed of two blocks: the upper block A with spin-5/2 and the bottom one B with spin-3/2. In the first instance, the effect of number of layers is studied in order to determine the optimal number of layers to select. The influence of exchange coupling and crystal fields constants on total and sublattice magnetizations, susceptibilities, and internal energy is deduced for specific parameters. The phase diagrams under the effect of different parameters have also been established. Moreover, we analyzed the hysteresis cycles for selected values of temperature, exchange coupling interaction and the crystal fields. At last, we noticed that our findings are comparable with the results of theoretical and experimental studies carried out by others.

### References

1. W. Jiang, J. Chen, B. Ma, Z. Wang, Physica E, 61 (2014) 101.
2. H. Saadi, R. Aharrouch, M. Madani, N. Hachem, M. El Bouziani, Phys. Met. Metallogr.122, (2021) 1158

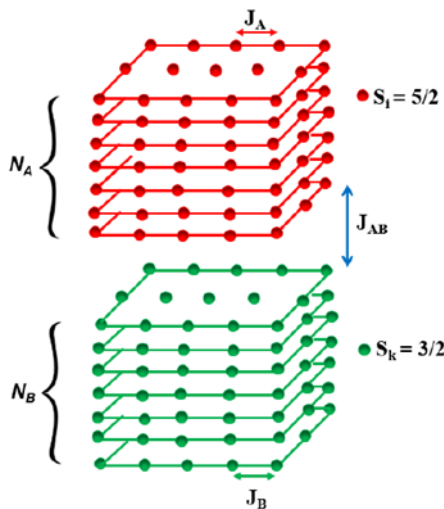

Fig: Schematic representation of a multilayer BC system with two blocks : A occupied by  $S_i = 5/2$  and B occupied by  $S_k = 3/2$



*I have expertise se in the field of materials physics, focusing on phase transitions, magnetic properties, and nanoscale material studies. Through extensive research and the application of advanced techniques, I have developed a deep understanding of how materials behave under various conditions, especially for energy storage and conversion applications. My experience includes conducting Monte Carlo simulations and utilizing Density Functional Theory (DFT) to explore and predict material properties. With a strong foundation in both experimental and theoretical approaches, I contribute valuable insights to advancing sustainable materials within condensed.*

**Email:** saadihasnae9@gmail.com

## Damage and durability assessment of 3D printed materials: Effect of crack length, and orientation on structural integrity

Taoufik Hachimi, Fatima Majid, Fouad Ait hmazi, Nassima Naboulsi, and Ibrahim Mrani

Laboratory of Nuclear, Atomic, Molecular, Mechanical and Energetic Physics, University Chouaib Doukkali, El Jadida, Morocco

### Abstract

This study investigates the main factors affecting damage and crack propagation in 3D-printed polylactic acid (PLA), particularly focusing on how crack length impacts material lifespan across different orientations (0°, 45°, and 90°). Through static damage and reliability analyses, a predictive relationship between damage evolution and the life fraction  $\beta$  was established, revealing that as crack length increases, mechanical performance deteriorates significantly, highlighting the need for effective crack monitoring. A critical life fraction was identified for each orientation, beyond which static damage rapidly surpasses reliability:  $\beta \approx 0.17$  for 45°,  $\beta \approx 0.21$  for 90°, and  $\beta \approx 0.24$  for 0°, with a secondary threshold between  $\beta \approx 0.50$  and 0.70. The 0° orientation showed the greatest resistance to damage progression, followed by 45° and 90°, defining a toughness hierarchy with 0° as the most resilient.

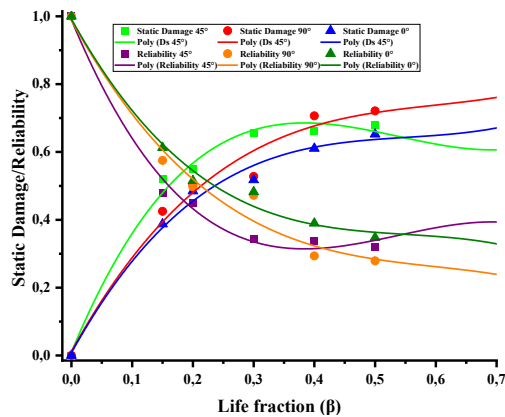

### References

1. F. Majid, T. Hachimi, H. Rhanim, and R. Rhanim, "Delamination effect on the mechanical behavior of 3D printed polymers," *Frattura ed Integrità Strutturale*, vol. 17, no. 63, pp. 26–36, 2023, doi: 10.3221/IGF-ESIS.63.03.
2. F. Majid and M. Elghorba, "HDPE pipes failure analysis and damage modeling," *Eng Fail Anal*, vol. 71, pp. 157–165, 2017, doi: <https://doi.org/10.1016/j.engfailanal.2016.10.002>.
3. T. Hachimi, F. Majid, N. Zekriti, R. Rhanim, and H. Rhanim, "Improvement of 3D printing polymer simulations considering converting G-code to Abaqus," *The International Journal of Advanced Manufacturing Technology*, vol. 131, no. 9, pp. 5193–5208, 2024, doi: 10.1007/s00170-024-13300-9.

**Fig: Evolution of static damage and reliability as a function of the fraction of life based on the remaining ultimate lives**



*Taoufik Hachimi is a researcher specializing in material mechanics and 3D printing, focusing on damage mechanics and crack propagation. With expertise in material characterization and CAD, he advances the durability and reliability of 3D-printed structures in high-performance applications.*

*Email: [Hachtaoufik@gmail.com](mailto:Hachtaoufik@gmail.com)*

ID : 166

## Utilizing Complementary Split-Ring Resonators for Effective Mutual Coupling Mitigation in Eight-Element Antenna Arrays

Sara Said<sup>1,2</sup>, Yassmina Guetbach<sup>2</sup>, El melhaoui ouafae<sup>1,2</sup>, Abdenacer Es-salhi<sup>2</sup>, Ahmed Faize<sup>3</sup>,  
Baghaz Elhadi<sup>4</sup>

<sup>1</sup>Research Center, High Studies of Engineering School, EHEI, Oujda, Morocco

<sup>2</sup>Department of Physics, Faculty of Sciences, University of Mohamed Premier, Oujda, Morocco

<sup>3</sup>Department of Physics, Polydisciplinary Faculty, University of Mohamed Premier, Nador, Morocco.

<sup>4</sup>Department of Physics, Faculty of Sciences, University of Chouaïb Doukkali, El Jadida, Morocco

### Abstract

The paper investigates a novel strategy for reducing mutual coupling in an eight-element antenna array utilizing Complementary Split-Ring Resonators (CSRR). These resonators are embedded within the ground plane, disrupting the surface currents that typically lead to unwanted electromagnetic interactions between closely spaced antennas. The integration of CSRRs yields substantial isolation enhancements, achieving mutual coupling levels as low as -60 dB, which is vital for optimizing MIMO system performance. Furthermore, the authors analyze how the presence of CSRRs influences the antenna array's radiation patterns and gain characteristics, demonstrating their effectiveness in maintaining signal integrity and improving overall operational efficiency in MIMO applications. The findings suggest that this design approach can significantly enhance the performance of compact antenna systems in modern wireless communications.

### References

1. Alibakhshkenari, M., Khalily, M., Virdee, B. S., See, C. H., Abd-Alhameed, R. A., & Limiti, E. (2019). Mutual-coupling isolation using embedded metamaterial EM bandgap decoupling slab for densely packed array antennas. *IEEE Access*, 7, 51827-51840.
2. Salamin, M. A., Zugari, A., Alibakhshkenari, M., See, C. H., Abd-Alhameed, R., & Limiti, E. (2023). Compact highly isolated dual-band 4-port MIMO antenna for sub-6 GHz applications. *Journal of Electromagnetic Waves and Applications*, 37(10-12), 1023-1043.
3. Mahto, S. K., Singh, A. K., Sinha, R., Alibakhshkenari, M., Khan, S., & Pau, G. (2023). High isolated four element MIMO antenna for ISM/LTE/5G (Sub-6GHz) applications. *IEEEAccess*.



ID: 169

## Effects of Rashba Spin-Orbit Interaction on Quantum Entanglement and Coherence Between Non-Interacting Electrons

Chaimae Banouni<sup>1</sup>, Mostafa Mansour<sup>2</sup>, Mohamed Ouchrif<sup>1</sup>

<sup>1</sup>Laboratory of Physics of Matter and Radiations, Department of Physics, Faculty of Sciences, Mohamed First University, National institute for Particle Physics and Applications, Oujda, Morocco.

<sup>2</sup>Laboratory of High Energy Physics and Condensed Matter, Department of Physics, Faculty of Sciences Ain Chock, Hassan li University, Casablanca, Morocco.

### Abstract

This research explores the influence of the Rashba spin-orbit interaction on quantum entanglement and coherence between two non-interacting electrons in a two-dimensional electron gas (2DEG) system, a key platform for studying fundamental quantum properties.

To accurately quantify entanglement within this system, we use concurrence (C), and to evaluate quantum coherence, we use the l1- norm (C11). Our analysis demonstrates that specific values of the Rashba SOC parameter can efficiently modulate both quantum entanglement and coherence, providing a versatile way to control these valuable quantum resources in response to system parameters. Notably, our results reveal that optimal values of these quantum metrics emerge when electrons are in close proximity, highlighting the crucial role of inter-electronic distance in determining quantum properties. As this distance increases, both entanglement and coherence metrics gradually decrease, emphasizing a significant dependence on spatial factors within 2DEG systems. However, by fine-tuning the Rashba parameter, it becomes possible to extend the persistence of these quantum resources even as electron separation increases, offering promising avenues for improving the control and optimization of quantum behavior in 2DEG-based applications involving qubits and quantum information processing. Furthermore, our results indicate that the l1 - norm exhibits greater robustness compared to concurrence, suggesting effective strategies for maintaining quantum coherence under various experimental conditions.

The results of this study pave the way for future research focusing on fine-tuning the Rashba SOC as a practical control mechanism for optimizing entanglement and coherence in quantum technologies, highlighting the potential of 2DEG systems in advancing quantum computing and information technology applications.

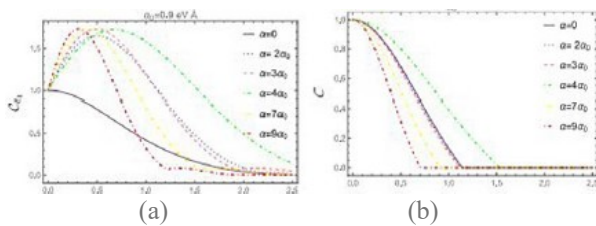

**Fig: Dynamical behavior of C11 (a) and C (b) as a function of R for various intensities with  $\alpha_0 = 0.9 \text{ eV \AA}$**

### References

1. C. Banouni, Z. Bouafia, M. Mansour, and M. Ouchrif, Mod. Phys. Lett. A 39, 2450128 (2024).
2. J. I. Aranzadi and P. I. Tamborenea, Phys. Rev. B 108, 115408 (2023).
3. V. Vedral, Cent. Eur. J. Phys. 1,289 (2003).
4. Z. Bouafia and M. Mansour, Laser Phys. Lett. 20, 125204 (2023).



*BANOUNI Chaimae is a PhD student at the University Mohammed I of Oujda, affiliated with the National institute for Particle Physics and Applications. Her dissertation research focuses on quantum information. Previously, she received a bachelor's degree in physical sciences from the University Mohammed I of Oujda in 2021 and a master's degree in matter and radiation in 2023.*

*Email: banounichaymae1@gmail.com*



ID : 170

### Estimation of rebar diameter using GPR data

Hamdaoui Mohammed<sup>1</sup>, Tahar Bachiri<sup>2</sup>, Bendaoued Mohammed<sup>3</sup>, Lakrit Soufian<sup>4</sup>, Faize Ahmed<sup>4</sup>, Elhadi Baghaz<sup>5</sup>, Sara Said<sup>6</sup>

<sup>1</sup>Mathematics and Information Systems Laboratory, FP of Nador, Mohammed First University, Oujda, Morocco

<sup>2</sup>PhD in Civil and Engineering, Faculty of Sciences and Technology, Abdelmalak Essaidi University, Tanger 91001;

<sup>3</sup>LMIET FST of Settat, University of Hassan 1st, Morocco

<sup>4</sup>Mathematics and Information Systems Laboratory, EST of Nador, Mohammed First University, Oujda, Morocco

<sup>5</sup>Laboratory of Electronics, Instrumentation and Energetic, Faculty of Sciences, Chouaib Doukkali University, B.P 20, ElJadida, Morocco

<sup>6</sup>Department of Physics, Faculty of Sciences, University of Mohamed Premier, Oujda, Morocco

#### Abstract

Ground Penetrating Radar (GPR) is a non-destructive approach that is particularly suitable for the detection of metal reinforcement within reinforced concrete structures. This study is dedicated to the location and precise evaluation of the diameter of the rebar integrated into such structures. To this end, experiments were carried out on a specially designed concrete slab, incorporating different types of reinforcement with different diameters and depth of cover. The data were collected in the form of B-scan radargrams and subjected to image processing, using a 2700 MHz antenna, thus allowing the analysis of amplitudes and echo widths based on an energy model. The results obtained indicate a satisfactory convergence between the estimated diameter and the actual value.

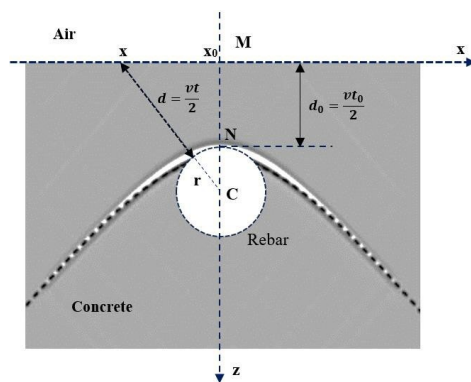

Fig: Geometric characteristics of a rebarburied in concrete

#### References:

1. Bachiri, T., Khamlichi, A., Hamdaoui, M., Bezzazi, M., & Faize, A. (2024). Numerical modelling of bridge deck reinforcement corrosion based on analysis of GPR data. *International Review of Applied Sciences and Engineering*;
2. H. W. Yang, Z. kun Yang, and Y. kun Pei, " Ground- penetrating radar for underground and underground pipelines using the Advanced Modeling Simulation Method ," *Optik*, Vol. 125, No. 23, pp. 7075-7079, Dec. 2014.
3. J. Lachowicz and M. Rucka, " A New Heterogeneous Concrete Model for Numerical Modeling of Ground- Penetrating Radar ," *Constr. Build. Mater.*, vol. 227, p. 116703, Dec. 2019.
4. W. Wai-Lok Lai, X. Dérobert and P. Annan, " A Review of the Application of Ground-Penetrating Radar in Civil Engineering: A 30-Year Journey from Location and Testing to Imaging and Diagnosis ," *CND E Int.*, vol. 96, pp. 58-78, June 2018.
5. Bachiri, T., Alsharahi, G., Khamlichi, A., Bezzazi, M., & Faize, A. (2020). GPR application in Civil Engineering to search and detect underground Networks. *Int. J. Emerg. Trends Eng. Res.* 8(5);
6. Bachiri, T., Khamlichi, A., & Bezzazi, M. (2018). Bridge deck condition assessment by using GPR: a review. In *MATEC Web of Conferences* (Vol. 191, p. 00004). EDP Sciences;
7. K. Ambika Lakshmi, Bhaskar Sangoju, Vasantha kumar, and Alfa Rahamath, « Estimation Of Rebarradius Using Ground Penetrating Radar » *International Journal of Emerging Technology in Computer Science & Electronics*, Volume 22 Issue 2 – MAY 2016.
8. Z. Mechbal and A. Khamlichi, " Determination of the characteristics of concrete rebar by enhanced post- processing of GRP raw scan data ", *CND E Int.*, vol. 89, pp. 30-39, July 2017.
9. X. Ma, H. Liu, M. L. Wang, and R. Birken, " Automatic Detection of Steel Rebar in Bridge Decks from Ground-Penetrating Radar Data ," *J. Appl. Geophys.*, vol. 158, pp. 93-102, November 2018.
10. K. Agred, G. Klysz et J.-P. Balayssac, « Emplacement de l'armature et évaluation de l'humidité dans le béton armé avec une antenne GPR à double récepteur », *Constr. Build. Mater.*, vol. 188, p. 1119-1127, novembre 2018.
11. D. J. Clem, T. Schumacher, and J. P. Deshon, " A Consistent Approach for the Processing and Interpretation of Concrete Bridge Element Data Collected with a Handheld GPR Device ," *Constr. Build. Mater.*, vol. 86, pp. 140-148, July 2015.



**Mohammed HAMD AOUI** is a PhD student and researcher in physics and engineering at the Laboratory of Electromagnetism, Plasma Physics and Applications (MASI laboratory) of the Multidisciplinary Faculty of Nador (FPN), Morocco. His contributions as an author, lecturer, and reviewer for internationally indexed journals in the fields of applied science and engineering are widely recognized. His expertise and commitment to non-destructive testing (NDT) detection techniques have allowed him to actively participate in the advancement of knowledge and the development of innovative solutions in the field of civil and geophysical engineering.

**Email :** hamdaoui.mohammed@ump.ac.ma; hamdawimohammedpc@gmail.com.

## Effects of Collision and Ionization Frequencies on Ion and Electron Flux Behavior in Magnetized Non-Extensive Plasma Sheath.

Oussama JDAINI <sup>1</sup>, Abdelhak MISSAOUI <sup>2</sup>, Mohamed EL BOJADDAINI <sup>1</sup>, Morad EL KAOUINI <sup>1</sup> and Hassan CHATEI <sup>2</sup>

<sup>1</sup>MASI Laboratory, Electromagnetism, Plasma Physics and Applications, Polydisciplinary Faculty of Nador, Mohammed I University, Nador, Morocco.

<sup>2</sup>Laboratory of Physics of Matter and Radiation, Faculty of Science, Mohammed I University, Oujda, Morocco.

### Abstract

This study investigates the properties of a magnetized plasma sheath composed of positive ions, electrons, and neutral particles. A fluid model based on continuity and momentum equations is employed, incorporating an ion source term and collision frequency. The electron distribution is described using Tsallis' non-extensive statistics. Through the Sagdeev potential approach, a modified Bohm sheath criterion is derived to determine the required ion velocity at the sheath edge. Additionally, the ion flux, electron flux, and floating electric potential are calculated. The governing equations are numerically solved using the fourth-order Runge-Kutta method. The sheath properties are analyzed with a focus on the impact of the non-extensive parameter  $q$ , ionization frequency  $\gamma$ , magnetic field angle  $\theta$ , and collision frequency  $\epsilon$ . Our results show that an increased collision frequency  $\epsilon$  reduces ion flux due to significant energy dissipation within the sheath and leads to increased sheath thickness. Conversely, higher ionization frequencies  $\gamma$  generate more ions, enhancing ion flux near the sheath edge and increasing sheath thickness. Also, the magnetic field angle  $\theta$  significantly affects ion flux: as  $\theta$  increases, ion movement becomes more restricted, resulting in reduced flux and greater sheath thickness. The electron flux exhibits a high initial value near the sheath edge, followed by a rapid decrease with distance. This decrease is influenced by ionization frequency and magnetic field angle: higher ionization frequencies lead to a faster reduction in flux, while larger magnetic field angles provide stronger confinement, further contributing to a slower reduction. Moreover, higher ionization frequencies and larger magnetic field angles result in an increased sheath thickness. Finally, the floating potential shows a monotonic decrease with increasing  $q$ , converging to zero as the plasma approaches classical behavior.



**JDAINI Oussama**, Ph.D. student at the MASI Laboratory, Electromagnetism, Plasma Physics and Applications, Polydisciplinary Faculty of Nador, Mohammed I University, Nador, Morocco. His research interests include plasma physics.

**Email:** [oussama.jdaini@ump.ac.ma](mailto:oussama.jdaini@ump.ac.ma)

## Design of a Multiband Pattern Reconfigurable Antenna for 5G Millimeter- Wave Frequency Applications

Rafik Er-rida, Chakib Taybi, Bachir Elmagroud, Meryem Bekkouch and Khalid El Youssefi

Electromagnetic and Dosimetry Team, Electronic and Systems Laboratory, National School of Applied Sciences, Mohammed First University, Oujda, Morocco

### Abstract

Recent advancements in applications and technologies in the fields of healthcare, media, industry, and energy have been associated with a rapid growth in connected devices, necessitating innovations in mobile telecommunications systems. In this context, reconfigurable antennas offer advantages such as multifunctionality and a reduced footprint.

This paper presents the design of a multi bands compact, reconfigurable microstrip patch antenna for 5G applications operating within the millimeter-wave (mmWave) range. The antenna consists of a rectangular monopole radiator and two radiating poles to adjust the desired radiation distribution. With dimensions of  $5,5 \times 5,5 \times 0,6 \text{ mm}^3$ , it is fabricated on a Rogers RT5880LZ substrate (thickness of 0,58 mm, permittivity of 2,0). By controlling two diodes to switch its operating modes, the antenna can redirect the main beam in the XY plane at  $157^\circ$  and  $20^\circ$  (gain of 0,91 dBi, angular width of  $186,2^\circ$ ) at 26,71 GHz with an impedance bandwidth of 1,68 GHz. At 44,10 GHz, it directs the beam at  $152^\circ$  and  $28^\circ$  (gain of 4,13 dBi, angular width of  $71^\circ$ ) with an impedance bandwidth of 2,79 GHz. Finally, at 60 GHz, the beam is directed at  $102^\circ$  and  $78^\circ$  with a gain of 5,09 dBi and an angular width of  $80,2^\circ$ , achieving an impedance bandwidth of 4,32 GHz. These configurations depend on the diode states (D1 ON, D2 OFF) and (D1 OFF, D2 ON).

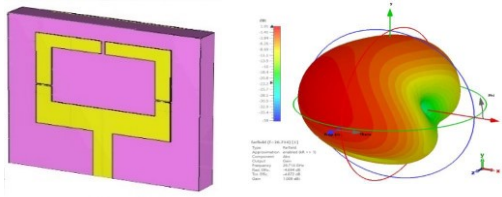

**Fig: Structure and Radiation Pattern of the proposed Antenna at 26GHz**

### References

1. Zhang Y, Han Z, Tang S, Shen S, Chiu CY. A highly pattern-reconfigurable planar antenna with  $360^\circ$  single- and multi-beam steering. *IEEE Trans Antennas Propag* 2022;70:6490–504. <https://doi.org/10.1109/TAP.2022.3161514>.
2. Chen Z, Song Z, Liu H, Liu X, Yu J, Chen X. A compact phase-controlled pattern-reconfigurable dielectric resonator antenna for passive wide-angle beam scanning. *IEEE Trans Antennas Propag* 2021;69:2981–6. <https://doi.org/10.1109/TAP.2020.3030549>.
3. V. Suryapaga and V. V. Khairnar, "Review on Multifunctional Pattern and Polarization Reconfigurable Antennas," in *IEEE Access*, vol. 12, pp. 90218–90251, 2024, doi: 10.1109/ACCESS.2024.3420426.
4. GANESH, M., RAGHAVA, N. S., SABAPATHY, Thennarasan, et al. A Gain-Enhanced Multiband Frequency and Pattern Reconfigurable Antenna for Wi-Fi 6E and 5G New Radio Wireless Standards. *International Journal of Communication Systems*, 2024, p. e6011.



*Rafik Er-rida has expertise in Electronic Engineering, Telecommunications Engineering, Electrical Engineering, with specialized skills: Microwave and Antenna Engineering, Electromagnetics, Antenna Design, Electronic Engineering, Antennas and Propagation.*

**Email:** r.errida@ump.ac.ma



*Chakib Taybi was born in Oujda, Morocco, on October 09, 1981. He received the BS degree (with honors) in electronics, MS degree (with honors) in electronics and telecommunication systems and Ph.D. degree in electronics and electromagnetics (with honors) from Mohammed First University, Oujda, Morocco, in 2008, 2010 and 2018 respectively.*

*He is currently an associate researcher in Electronic and Systems Laboratory (LES) at Mohammed First University. His main areas of interest are near field antennas measurement, anechoic/reverberation chambers characterization and electromagnetic exposition evaluation.*

*Taybi is a member of the Institute of Electrical and Electronics Engineers (IEEE), Antennas and Propagation Society (AP-S), Electromagnetic Compatibility Society (EMC-S) and Microwave Theory and Techniques Society (MTT-S).*

**Email:** ch.taybi@ump.ac.ma

## Numerical Study of Sheath Formation and Characteristics in a Magnetized Non-Extensive Plasma with Secondary Electron Emission

Zakariyae El Ankouri<sup>1</sup>, Mohamed El Bojaddaini<sup>1</sup>, Morad El Kaouini<sup>1</sup>, Hassan Chatei<sup>2</sup>

<sup>1</sup>MASI Laboratory, Polydisciplinary Faculty of Nador, Mohammed I University, Nador, Morocco.

<sup>2</sup>Laboratory of Physics of Matter and Radiation, Faculty of Science, Mohammed I University, Oujda, Morocco.

### Abstract

This study numerically investigates sheath formation and structure in a magnetized plasma with non-extensive primary electrons, positive ions, and secondary electron emission. The plasma sheath is modeled using continuity and momentum conservation equations coupled with Poisson's equation. Primary electrons follow a non-extensive distribution based on Tsallis statistics, while positive ions and secondary electrons are described with a steady-state fluid model. By employing the Sagdeev potential, a generalized Bohm criterion for sheath formation in a magnetized plasma is derived. The results reveal a significant influence of key physical parameters, including the secondary electron emission coefficient, magnetic field orientation, and the non-extensivity parameter on the Bohm criterion and sheath characteristics. Notably, increases in both the non-extensivity parameter and magnetic field orientation reduce the ion velocity at the sheath edge, highlighting the critical role of these parameters in sheath formation. This study may benefit technological applications in plasma processing for the semiconductor industry, electronic device manufacture, and fusion research.

### References

1. M. El Bojaddaini, M. El Kaouini, and H. Chatei, "Sheath structure behavior in collisional non-extensive plasma with negative ions," *The European Physical Journal Plus* 139 (5), 373 (2024).
2. H.K. Malik, Y.P. Jha, and M. Kumar, "Modified Bohm Criterion and Sheath Characteristics in Nonextensive Electronegative Collisional Warm Plasma With Electron Emitting Surfaces," *IEEE Transactions on Plasma Science*, 1–13 (2024).
3. G. Sharma, R. Paul, K. Deka, R. Moulick, S. Adhikari, S.S. Kausik, and B.K. Saikia, "Study of two-electron temperature plasma sheath using non-extensive electron distribution in presence of an external magnetic field," *AIP Adv* 13 (1), (2023).
4. A. Asserghine, A. Missaoui, M. El Kaouini, and H. Chatei, "Numerical study of the effect of secondary electron emission on the sheath characteristics in q-non-extensive plasma," *Contributions to Plasma Physics* 62 (1), (2022).



*Zakariyae El Ankouri obtained a License degree in Fundamental Physical Sciences from the Polydisciplinary Faculty of Nador (FPN) in 2021 and a Master's degree in Materials and Energy from the same faculty in 2023. He is currently a Ph.D. student in plasma physics at the MASI Laboratory, Polydisciplinary Faculty of Nador, Mohammed First University, Nador, Morocco. His research focuses on plasma-surface interactions.*

*Email: [zakariyae.elankouri@ump.ac.ma](mailto:zakariyae.elankouri@ump.ac.ma)*

## Discharge Frequency-Dependent Plasma Reflectors in Antenna Design: Modeling and Simulation for Enhanced Gain and Directivity

Ayoub Eljaouhari <sup>1</sup>, Abdelhak Missaoui <sup>2</sup>, Majid Rochdi <sup>1</sup>, Morad El Kaouini <sup>1</sup>

<sup>1</sup> LMASI, Electromagnetism, Physics of Plasmas and Applications, Polydisciplinary Faculty of Nador, Mohammed I University, Selouane 62700, Morocco.

<sup>2</sup> Laboratory of Physics of Matter and Radiation, Faculty of Sciences, Mohammed I University, Oujda 60040, Morocco.

### Abstract

This work investigates the radiation patterns at two different frequencies, 1.5 GHz and 2.5 GHz, for antenna composed of a metallic dipole antenna and a plasma reflector (discharge tubes), an alternative to traditional metallic reflectors. Plasma reflectors offer potential advantages, such as tunability and weight reduction, which can enhance antenna efficiency by controlling the radiation pattern. The plasma medium's electrical parameters are theoretically modeled using the Drude model, helping to determine the conditions under which plasma can function as a reflector by analyzing its electric permittivity and conductivity. COMSOL Multiphysics, chosen for its effectiveness in simulating variations of discharge frequency within a capacitively coupled plasma (CCP), models how these changes effect on electron density and collision frequency. These results serve as input parameters for CST software to simulate the radiation pattern and simulate the gain across different discharge frequencies. The results demonstrate that as discharge frequency increases, plasma reflectivity increase with discharge frequency, resulting in significant improvements in gain and notable changes in antenna directivity. This study highlights the potential of plasma reflectors in advanced antenna design, for improved efficiency in many applications like GPS and WIFI.

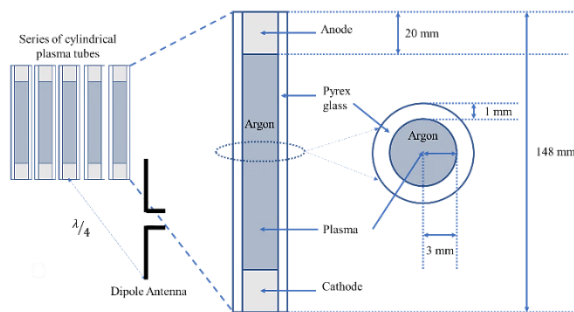

Fig: Plasma reflector geometry

### References

1. ANDERSON, Theodore. Plasma antennas. Artech House, 2020.
2. Podolsky, V, et al, S. O. (2020). Experimental and Numerical Studies of a Tunable Plasma Antenna Sustained by RF Power. IEEE Transactions on Plasma Science, 1–11
3. Kamboj, G. K,et al, R. S. (2021). Development of Reconfigurable Plasma Column Antenna. IEEE Transactions on Plasma Science, 49(2), 656–662.



**Ayoub El jaouhari** received the License degree in Physical science from Multidisciplinary Faculty of Nador (FPN) in 2018 and the Master degree in Materials and Energies from FPN of Nador in 2021. The PhD student on plasma antenna and electromagnetic waves in Faculty of Sciences, Mohammed I University of Oujda. His research interests include plasma antennas and plasma reflectors.

**Email:** ayoub.eljaouhari@ump.ac.ma



## Investigation of Radio Frequency Sheath Structure in Electronegative Plasma with Cairns–Tsallis Electron Distribution

Mohamed Bouzraa<sup>1</sup>, Abdelhak Missaoui<sup>2</sup>, Morad El Kaouini<sup>1</sup>, Mohamed El Bojaddaini<sup>1</sup>, Hassan Chatei<sup>2</sup>

<sup>1</sup>EPPA, LMASI, Department of Physics, Polydisciplinary Faculty of Nador, Mohammed First University, Nador, Morocco.

<sup>2</sup>LPMR, Department of Physics, Faculty of Science, Mohammed First University, Oujda, Morocco

### Abstract

This paper examines the behavior of a radiofrequency (RF) plasma sheath containing electrons, positive ions and negative ions. The RF sheath structure is numerically analyzed using a one-dimensional hydrodynamic model, combined with an equivalent circuit model. The electrons are assumed to follow a Cairns-Tsallis distribution, while positive ions are described by a fluid model, and negative ions are considered to obey a Boltzmann distribution. The equivalent circuit model, consisting of a parallel combination of a diode, a capacitor, and a current source, is used to determine the spatiotemporal variation of the electric potential at the wall. Results show a significant impact of the negative ions on the plasma sheath structure. It is also shown that a decrease in the non-extensivity parameter, as well as an increase in non-thermality lead to an increase in potential drop and sheath thickness during a radiofrequency cycle.

### References

1. Ou J and Men Z, "Formation of the radio frequency sheath of plasma with Cairns–Tsallis electron velocity distribution", Phys. Plasmas (2020)
2. D. R. Borgohain and K. Saharia "Characteristics of Electronegative Plasma Sheath with q-Nonextensive Electron Distribution", Plasma Physics Reports (2018)
3. M El Bojaddaini, M El Kaouini, H Chatei "Sheath structure behavior in collisional non-extensive plasma with negative ions" The European Physical Journal Plus, (2024)
4. M El Bojaddaini, M El Kaouini, H Chatei "Sheath structure behavior in collisional non-extensive plasma with negative ions" The European Physical Journal Plus, (2024)



**BOUZRAA Mohamed** obtained a License degree in Fundamental Physical Sciences from the Polydisciplinary Faculty of Nador (FPN) in 2020 and a Master's degree in Materials and Energy from the same faculty in 2022. He is currently a Ph.D. student in plasma physics at the MASI Laboratory, Polydisciplinary Faculty of Nador, Mohammed First University, Nador, Morocco. His research focuses on plasma-surface interactions.

**Email:** mohamed.bouzraa@ump.ac.ma

ID : 204

## Modeling and Experimental Analysis of Non-Fickean Water Desorption in Elastic and Deformable Couscous Grains

H. BAGAR<sup>1</sup>, F. AIT HMAZI<sup>1</sup>, I. MRANI<sup>1</sup>, A. EL AFIF<sup>2</sup>

<sup>1</sup> Laboratory of Atomic, Molecular, Mechanical and Energetic Physics. Department of Physics. Chouaib Doukkali University. El Jadida, Morocco.

<sup>2</sup> Innovation Laboratory in Technological Sciences and Modelling (ISTM). Department of Physics. Chouaib Doukkali University. El Jadida, Morocco

### Abstract

We investigate here, through experimental and numerical approaches, the unsteady desorption process of water in a spherical, elastic, and deformable granular medium. Experiments were conducted at 30 and 40 °C on couscous grains in a controlled humidity environment to observe water behavior under different relative humidity levels. A modified elastic model was employed, expressing the water continuity equation in spherical Lagrangian coordinates to account for volume changes in the grains during desorption. The unidirectional radial desorption process was then analyzed through scaling analysis coupled with numerical resolution. Modeling results were successfully compared to experimental data, providing strong validation for the theoretical model. Additionally, the study focuses on the effects of a diffusion-elasticity coupling constant  $\psi$ , which naturally emerges in the continuity equation and plays a key role in desorption dynamics. Findings show that for high values of  $\psi$ , the water desorption process in couscous grains becomes non-Fickean, highlighting the importance of coupling between diffusion and elasticity.

### References

1. Hamza BAGAR, Ali. EL AFIF et Ibrahim MRANI, « Experimental investigation and mathematical modeling of the unsteady drying kinetics of durum wheat grains », Moroccan Journal of Chemistry, vol. 9, no 3, Art. no 3, nov. 2021, doi: 10.48317/IMIST.PRSM/morjchem-v9i3.26982.
2. F. Ait Hmazi, H. Bagar, A. Madani, et I. Mrani, « A novel approach for modelling and predicting the drying kinetics of couscous grains using artificial neural networks », J. Food Compos. Anal., vol. 132, p. 106301, août 2024, doi: 10.1016/j.jfca.2024.106301



Author has expertise in Mechanical Engineering

Email : [bagar.h@ucd.ac.ma](mailto:bagar.h@ucd.ac.ma)

## Qualitative Evaluation of the Error of the Near-Field Measurement Probe at 5G Frequencies of Mobile Networks

Rafik Er-rida<sup>1</sup>, Meryem Bekkouch<sup>1</sup>, Chakib Taybi<sup>1</sup>, Abdechafik Derkaoui<sup>1</sup>, Bachir Elmagroud<sup>1</sup>, Mohammed Anisse Moutaouekkil<sup>1</sup> and Chaieb Elbekkaye<sup>2</sup>

<sup>1</sup> Electromagnetic and Dosimetry Team, Electronic and Systems Laboratory, National School of Applied Sciences, Mohammed First University, Oujda, Morocco

<sup>2</sup> Electronics and devices for renewable energies Team, Electronic and Systems Laboratory, National School of Applied Sciences, Mohammed First University, Oujda, Morocco

### Abstract

The work presented in this paper focuses on the problem of characterizing the measurement probe error in antenna measurement systems using near-field techniques at 5G frequencies in mobile networks. Three types of probes were evaluated in this study, and a moderate gain antenna has been used as an Antenna Under Test (AUT). The first probe is a half-dipole used as reference probe, the second one is an Open-Ended Rectangular Wave Guide (OERWG) probe and the third one is a pyramidal horn used in the most calibrated antenna gain systems. The exact distribution of the near electric field has been compared to the voltage at the output of each probe at two particular frequencies, the first one is 6GHz of the sub-6GHz band and the second one is 54GHz localized at millimetric wave band (mmW). In addition, the electric field and the probe output signal are both sampled in planar and cylindrical systems using numerical MOM method available in FEKO Suite software.

The obtained results given in Figure shown that, the absolute error of the probes is function of: (1) the surface sensitive to the electromagnetic flux radiated by AUT, (2) the response of the probes to the parasitic components of the field, (3) the type of the antennas measurement systems and (4) the interaction Probe-AUT. This last point becomes more important when the operating frequencies increase. In fact, when the operating frequency increases, the dimension of the antennas and the probes decrease, also, as the frequency increases, the dimensions of the antennas and probes become increasingly miniature, and consequently the distance Probe-AUT becomes increasingly very nearby.

In summary, the results of our study allowed us to understand well how the error of the measuring probe changes depending on the frequency, and a correction step becomes important to remedy the problems of the probe.

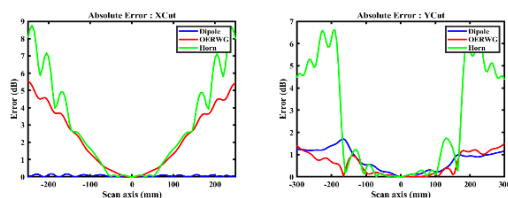

Fig: XCut and YCut of the probes error

### References

1. Ch.Taybi, M. A. Moutaouekkil, B. Elmagroud, A. Ziyat, "A novel methodology for time-domain characterization of a full anechoic chamber for antennas measurements and exposure evaluation", International Journal of Electrical and Computer Engineering, iaes,11,pp: 3285-3292,DOI: 10.11591/ijece.v11i4.pp3285-3292
2. Ch.Taybi, A. Derkaoui, Kh. Salmi, M. A. Moutaouekkil, B. Elmagroud, A. Ziyat, "Geometrical and Analytical Methods for Probes Correction applied to Near Field Antennas Measurement Systems", 7th Mediterranean Congress of Telecommunications, IEEE Xplore Digital Library, Fez, Maroc, 10.1109/CMT.2019.8931322
3. Ch.Taybi, M. A. Moutaouekkil, A. Ziyat, "Caractérisation des sondes de mesure d'antennes en champ proches", Congrés Méditerranéen des Télécommunications, (CMT), Tétouan, Maroc
4. Ch.Taybi, M. A. Moutaouekkil, A. Ziyat, "Correction des Sondes pour Les Systèmes Planaires de Mesure d'Antenne en Champ Proche", Congrés Méditerranéen des Télécommunications, (CMT), Tétouan, Maroc



## Miniaturization of Antennas Using Metamaterial Techniques for Next-Generation Wireless Applications

Sara Said<sup>1,2</sup>, Hamdaoui Mohammed<sup>3</sup>, AbdenacerEs-salhi<sup>2</sup>, Ahmed Faize<sup>3</sup>, BaghazElhadi<sup>4</sup>

<sup>1</sup>Research Center, High Studies of Engineering School, EHEI, Oujda, Morocco

<sup>2</sup>Department of Physics, Faculty of Sciences, University of Mohamed Premier, Oujda, Morocco

<sup>3</sup>Department of Physics, Polydisciplinary Faculty, University of Mohamed Premier, Nador, Morocco.

<sup>4</sup>Department of Physics, Faculty of Sciences, University of Chouaib Doukkali, El Jadida, Morocco

### Abstract

The miniaturization of antennas is a critical advancement in modern communication systems, driven by the increasing demand for compact, high-performance devices in applications like IoT, mobile communications, and 5G networks. One of the most promising approaches to achieve significant size reduction without compromising performance is the use of metamaterials. Metamaterials are artificially engineered structures with unique electromagnetic properties not found in natural materials, enabling precise control over wave propagation. This paper explores the use of metamaterial-based techniques for antenna miniaturization, focusing on designs that integrate periodic structures and resonant elements, such as split-ring resonators (SRRs) and complementary split-ring resonators (CSRRs). These structures allow for effective permittivity and permeability manipulation, resulting in lower resonant frequencies in a smaller physical footprint. Additionally, employing LC resonant circuits within metamaterial elements provides enhanced control over bandwidth and radiation patterns.

Our study demonstrates that metamaterial-based antennas not only reduce physical dimensions but also maintain efficiency and directivity, making them ideal for integration in next-generation wireless systems. This technique is a promising solution for overcoming spatial constraints while achieving optimal performance, thereby advancing the development of compact and efficient antenna systems.

### References

1. Gong, Z., An, Z., Dai, D., Tong, J., Long, S., & Yang, L. (2024, May). Enabling cross-medium wireless networks with miniature mechanical antennas. In Proceedings of the 30th Annual International Conference on Mobile Computing And Networking (pp. 648-662).
2. Pigeon, M., & Barton, J. (2024, March). Miniaturised Magnetic Antenna for Wireless Implanted Medical Device. In 2024 18th European Conference on Antennas and Propagation (EuCAP) (pp. 1-5). IEEE.
3. Sharma, B. L., Mathur, D., & Sharma, M. K. (2024). Design of miniaturised circular polarisation-reconfigurable and frequency agile slow-wave SIW based microstrip antenna for wireless applications. International Journal of Electronics, 111(6), 952-974.



**ID : 218**

**Aerosol radiative forcing around the Mediterranean**

**Rajae. Meziane<sup>1</sup>, Mohammed. Diouri<sup>1</sup>, Abdelmoula. Ben-Tayeb<sup>1,2</sup>**

<sup>1</sup>Atmospheric physics team, FSO, Mohammed First University, Oujda, Morocco

<sup>2</sup>Mechanical Engineering Department, FST, Sultan Moulay Slimane University, Beni-Mellal, Morocco

**Abstract**

The aerosol optical depth AOD characterizes the transparency of the atmosphere vis-a-vis solar radiation, it provides information on the aerosol load and quantifies the extinction of incident radiation in a column of atmosphere both by absorption and by scattering (Ben-tayeb et al. 2021). The study of the monthly evolution of the AODs allows the determination of the seasonal aerosol concentration and types (Meziane et al. 2020; 2021;2022). This work focuses on the optical characterization of the aerosol around the Mediterranean and the determination of its radiative forcing for several representative North sites (NM), south (SM) and East (EM). AOD measurements are obtained using CIMEL photometers which equip the various sites of the AERONET network (Table 1).

The Mediterranean region observes a great diversity of aerosol sources (Desert, marine, forest, volcanic and anthropogenic). Despite the same Mediterranean climate, the contribution of the aerosol to the radiative forcing is different between the South and the East (more important) marked more by the natural aerosol and the North (less important) marked more by the anthropogenic aerosol. The climatic disturbance defined by the balance between the forcing at the top of the atmosphere and at the surface (CAB) shows a significant difference between NM and SM with an accentuation observed in Athens and Cairo.

**Table 1. Annual aerosol radiative forcing and AOD.**

Sites	BOA	TOA	CAB	AOD
<b>NM</b>				
Athens,NOA 2021	-29,93	-09,33	20.6	0.185
Toulon2021	-19,93	-08,01	11.92	0.135
OHP Observation 21	-13,51	-06,09	07.42	0.095
Barcelona 2021	-24,73	-09,96	14.77	0.185
Cut Tepak 2021	-23,47	-13,13	10.34	0.175
<b>SM</b>				
Tizi Ouzou 2017	<b>-34,29</b>	-11,59	22.7	<b>0.213</b>
Tunis 2019	-30,17	-08,51	21.66	0.188
Cairo2021	<b>-57,8</b>	<b>-18,91</b>	<b>38.89</b>	<b>0.345</b>

**References**

1. Ben-tayeb A, Diouri M, Meziane R et al (2021). Solar irradiance attenuation by aerosols in cloudless atmosphere: equatorial and temperate examples. Euro- Mediterr J Environ Integr 6:49. <https://doi.org/10.1007/s41207-021-00258-3>
2. Meziane, R., Diouri, M. and Ben-tayeb, A. (2020). Journal Air Quality, Atmosphere & Health 13, 25-33. <https://doi.org/10.1007/s11869-019-00769-7>
3. Meziane, R., Diouri, M., Ben-tayeb, A. et al. (2022). A decadal optical investigation (2009–2018) of anthropogenic aerosol of Beijing, China. Air Qual Atmos Health <https://doi.org/10.1007/s11869-021-01135-2>
4. Meziane, R., Diouri, M., Ben-tayeb, A. et al. (2021). Effect of the main active volcanoes on aerosol optical properties. E3S Web Conf. Volume 314. <https://doi.org/10.1051/e3sconf/202131403007>



**Rajae MEZIANE** received her PhD degree in Mechanics, Energy, Optics and Environment from Mohammed First University, Oujda Morocco.

her current research interests include teaching physics and research in global atmospheric of climate change and environment.

Email : [r.meziane@ump.ac.ma](mailto:r.meziane@ump.ac.ma)



## Transforming Production Planning: The Role of Industry 4.0 Technologies in Achieving Resilient and Efficient Logistics Systems

Kaouthar Siraji <sup>1</sup>, Yousra El Kihel <sup>2</sup>, Soufiane Embarki <sup>1</sup>, El Kihel Bachir<sup>1</sup>

<sup>1</sup> *Equipe du Génie Industriel ENSA OUJDA Maroc*

<sup>2</sup> *Laboratoire LINEACT-CESI France*

### Abstract

Industry 4.0 technologies have brought about a profound transformation in logistics and supply chain management, particularly in the area of production planning. Advanced technologies such as artificial intelligence, the Internet of Things and digital twins are making huge strides towards efficiency within operations. The strategic advantage of using these technologies lies in optimizing resource allocation, improving forecast accuracy and enabling real-time decision-making to meet the complex demands of today's production environments. They make a significant contribution to streamlining production flows by reducing lead times, minimizing waste and adapting seamlessly to fluctuating market demands, ensuring a more agile and resilient production process.

One of the cornerstones of this transformation is the integration of data from connected systems into dynamic planning and predictive analysis. Well-orchestrated data integration enables organizations to merge historical trends with real-time information, providing planners with actionable insights that lead to more informed and accurate decisions. This will continue to reshape traditional planning processes, making them more reactive, adaptive and proactive in the face of operational challenges and market volatility.

Furthermore, technologies are not limited to process optimization. They give companies the opportunity to improve collaboration between different stakeholders, increase visibility across the supply chain, and promote sustainability practices for resource conservation and waste reduction. Nevertheless, the adoption of Industry 4.0 technologies is not without its challenges. Most implementations will typically involve at least one major change in infrastructure, workforce training and overcoming data silos.

This article explores the critical impact of Industry 4.0 technologies on production planning, considering the potential benefits, implementation challenges and implications for achieving sustainable and resilient logistics systems in an increasingly dynamic and competitive environment.

**Table: literature review on production planning & technology 4.0**

Year	Title	Author(s)	Main Idea
2020	Machine learning applied in production planning and control: a state-of-the-art in the era of Industry 4.0	Juan Pablo UsugaCadavid, Samir Lamouri, Bernard Grabot, Robert Pellerin, Arnaud Fortin	Discusses the application of machine learning in production planning and control within Industry 4.0, focusing on the role of data and AI in modern manufacturing..
2021	Interdependencies within Production Planning and Control: An Approach for Generic Modelling of the Relationships between Production Planning and Control Tasks and Production Logistics Objectives	Simon Hillnhagen, Thorben Green, Janine Tatjana Maier, Alexander Mütze, Matthias Schmidt	Presents a model-based design approach that explores the inter-dependencies within production planning and control, by linking the goals and tasks of production logistics to provide clarity on the impact of decisions on all tasks.
2022	Digital Collaboration Platform for Distributed, Agile Engineering-Integration of an IT Approach and Indicators for Acceptance in Industrial SMEs	David Wagstyl, ThorbjörnBorggräfe, Sven Oberdiek, Leon Wagener, Jochen Deuse	This paper Presents a digital platform architecture for flexible collaboration in the design of production systems, integrating planning data and workflow management for SMEs. It also provides indicators for measuring platform adoption in medium-sized industrial companies.
2023	Energy-related material flow simulation in production and logistics	Sigrid Wenzel, Markus Rabe, Steffen Strassburger, Christoph von Viebahn	This paper Provides an overview of approaches and applications of energy issues in production and logistics using simulations. Highlights the significance of energy efficiency in material processes and the integration of energy management into planning processes, particularly with the use of regenerative energy sources.
2024	Production Scheduling Based on a Multi-Agent System and Digital Twin: A Bicycle Industry Case	Vasilis Siatras, EmmanouilBakopoulos, Panagiotis Mavrothalassitis, Nikolaos Nikolakis, Kosmas Alexopoulos	This paper Proposes a multi-agent system framework combined with digital twin technology to optimize production planning in the bicycle industry

### References

1. Moshood, T.D.; Nawanir, G.; Sorooshian, S.; Okfalisa, O. Digital Twins Driven Supply Chain VisibilitywithinLogistics: A New Paradigm for Future Logistics. Appl. Syst. Innov. 2021, 4, 29. <https://doi.org/10.3390/asi4020029>
2. Christos T. Maravelias\*, Charles Sung Department of Chemical and Biological Engineering, University of Wisconsin-Madison, 1415 Engineering Dr., Madison, WI, 53706, USA
3. M. Padrón, P. Resto, & J. Muñoz, "A fast lp-basedsolution to the production planning problem with capacityconstraintsincluding setup considerations", Journal of Manufacturing Technology Management, vol. 23, no. 2, p. 253-266, 2012. <https://doi.org/10.1108/17410381211202223>
4. K. McKay and G. Black, "The evolution of a production planning system: a 10-year case study", Computers in Industry, vol. 58, no. 8-9, p. 756-771, 2007. <https://doi.org/10.1016/j.compind.2007.02.002>



*The author has expertise in logistics and industrial engineering, with a focus on leveraging Industry 4.0 technologies to optimize supply chain processes. Currently a PhD student in logistics in Oujda, the author has professional experience as a Production Control and Logistics Analyst at Aptiv Oujda, managing production planning, delivery follow-ups, and capacity simulations. With proficiency in Lean Manufacturing methodologies, ERP systems like SAP and Odoo, and fluency in Arabic, French, and English, the author is dedicated to driving innovation and efficiency in logistics operations.*

## Optimization of Industrial Processes Through Digital Twin Solutions: Modeling, Monitoring, and Decision Making, Application to a Water Filtration Unit

Soufiane Embarki<sup>1</sup>, Yousra EL Kihel<sup>2</sup>, Bachir El Kihel<sup>3</sup>

<sup>1-3</sup> Laboratory of Applied Sciences Research, National School of Applied Sciences, Oujda, Morocco

Email: [s.embarki@ump.ac.ma](mailto:s.embarki@ump.ac.ma), [belkihel@yahoo.fr](mailto:belkihel@yahoo.fr)

<sup>2</sup>CESI Engineer School - LINEACT, Bordeaux, France

Email : [yelkiehl@cesi.fr](mailto:yelkiehl@cesi.fr)

### Abstract

The digital transformation of the industrial sector is a cornerstone of global economic development, focusing on improving productivity and sustainable growth. Advanced technologies such as cyber-physical systems, artificial intelligence, and the Internet of Things (IoT) enhance industrial systems, making them more complex yet adaptive. Among these advancements, Digital Twin (DT) technology offers real-time, virtual replicas of industrial equipment and processes. These replicas allow accurate modeling and monitoring, enabling companies to simulate scenarios, predict performances, and reduce on-site testing costs. Additionally, DT technology integrates real-time sensor data with advanced analytics to improve decision-making, operational performance, and predictive maintenance, significantly contributing to Industry 4.0.

This study focuses on implementing a Digital Twin solution in a water filtration unit, involving real-time monitoring and predictive failure analysis. The developed model will allow a proactive, holistic approach to optimizing industrial processes. The solution is developed in three stages: precise system modeling, integration of Industry 4.0 technologies for process optimization, and failure prognostics using advanced algorithms. This approach ensures continuous operational efficiency and reduced downtime.

**Keywords:** Digital Twin, Industrial Processes, Modeling, Monitoring, Decision Making, Optimization, Predictive Maintenance, Industry 4.0.

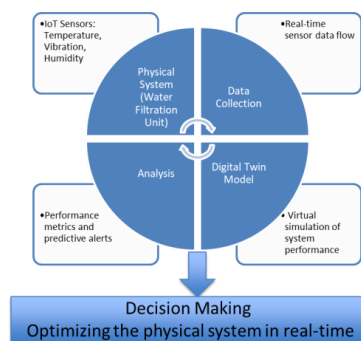

Digital Twin process model applied to a water filtration system, integrating

### References

- Attaran, M., & Celik, B. G. (2023). Digital Twin: Benefits, use cases, challenges, and opportunities. *Decision Analytics Journal*, 6, 100165.
- Tao, F., et al. (2019). Digital Twin in Industry: State-of-the-Art. *IEEE Transactions on Industrial Informatics*, 15(4), 2405-2415.
- Embarki, S., & EL Kihel, Y. (2023). Contribution to Maintenance 4.0 by Monitoring and Prognosis of Industrial Installations by Digital Twin: Case Study on Wastewater Filtration Pilot. *IDAACS*, pp. 113- 118.



*Soufiane Embarki specializes in digital transformation in industrial settings, focusing on real-time monitoring, optimization through predictive algorithms, and integration of Industry 4.0 technologies.*

Email : [s.embarki@ump.ac.ma](mailto:s.embarki@ump.ac.ma)

## Effect of Plasma Electron Density on Electromagnetic Wave Propagation using Kinetic Theory and FDTD Method

Maryame Chaou<sup>1</sup>, Morad El Kaouini<sup>1</sup>, Majid Rochdi<sup>1</sup>, Mohamed El Bojaddaini<sup>1</sup>

<sup>1</sup>Team of Electromagnetism, Plasma Physics and Applications, MASI Laboratory, Polydisciplinary Faculty of Nador, Mohamed First University, Morocco

### Abstract

This study explores the propagation of electromagnetic waves in a plasma medium by combining kinetic theory with Maxwell's equations. The finite-difference time-domain (FDTD) method is employed to solve the Maxwell-Boltzmann system, enabling the analysis of the evolution of electromagnetic fields and the electron distribution function within the plasma. The results show that plasma electron density has a significant impact on wave behavior. In plasmas with a low electron density, electromagnetic waves propagate through the medium with minimal interaction. Conversely, in plasmas with a high electron density, the waves are either reflected or absorbed by the medium.

### References

1. Cerri, G., et al., FDTD solution of the Maxwell-Boltzmann system for electromagnetic wave propagation in a plasma. IEEE transactions on antennas and propagation, 2008. **56**(8): p. 2584-2588.
2. Shahmohamadi, B., et al., Analysis of dipole plasma antenna using kinetic method and FDTD numerical approach. AEU-International Journal of Electronics and Communications, 2022. **145**: p. 154066.
3. Russo, P., G. Cerri, and E. Vecchioni, Self-consistent analysis of cylindrical plasma antennas. IEEE transactions on antennas and propagation, 2011. **59**(5): p. 1503-1511.
4. Ghaderi, M. and G. Moradi, Numerical Analysis of a Tunable Magnetized Plasma Loop Antenna. IEICE Transactions on Communications, 2018. **101**(4): p. 1055-1060.



---

◆

**Topic 3: Mathematical Modeling and Informatics  
Applications**

---

◆

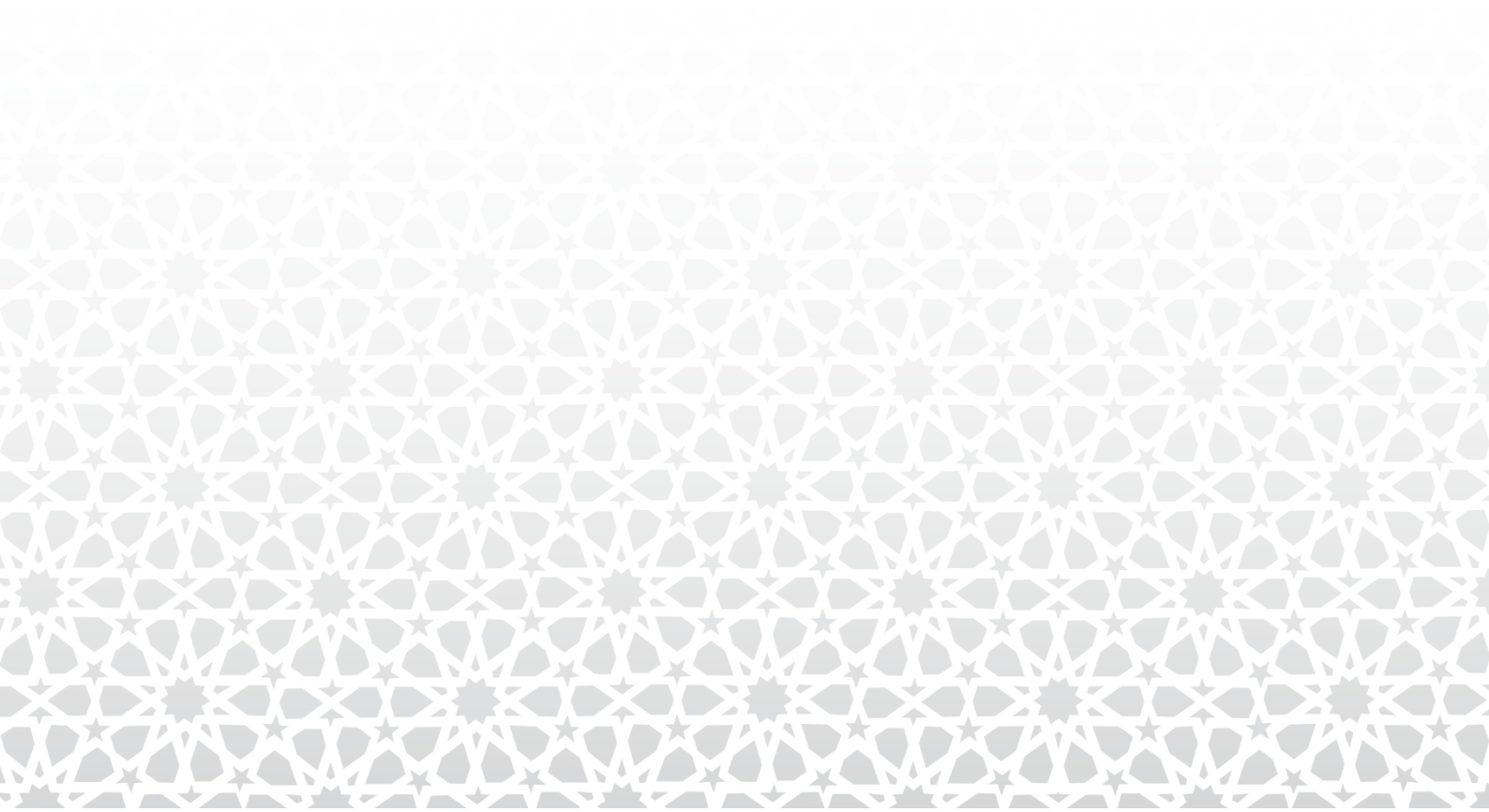

## An Ultra-Compact Wideband Low-Pass Filter Using a Multi-Objective Genetic Algorithm

Khadija Abouhssous<sup>1</sup>, Asmaa Zugari<sup>2</sup>, Moustapha El Bakkali<sup>3</sup> and Alia Zakriti<sup>1</sup>

<sup>1</sup> Laboratory of Science and Advanced Technology, Department of Civil and Industrial Sciences and Technologies, National School of Applied Sciences, Abdelmalek Essadi University, Tetouan, Morocco

<sup>2</sup> Information and Telecommunication System Laboratory, FS, Abdelmalek Essadi University, Tetouan, Morocco

<sup>3</sup> Department of Physics, Faculty of Sciences, Abdelmalek Essadi University, Tetouan, Morocco, Tetouan, Morocco

### Abstract

This study presents the design of an ultra-compact band-pass filter utilizing coupled microstrip lines, specifically tailored to meet the requirements of 5G mobile communication standards as well as WiMAX and WLAN applications. One of the remarkable aspects of our work is that, despite the sophistication of the required performance, the structure of the filter remains consistently simple and devoid of unnecessary complexity, facilitating its integration into various systems. The innovation of our approach lies in the use of a genetic algorithm, a method that effectively optimizes the filter parameters by exploring a vast search space. This allows us to identify the most efficient configurations while ensuring the robustness and reliability of the device. The results of this optimization are particularly promising: we have achieved a center frequency of 5.5 GHz, with a -3 dB bandwidth ranging from 2.4 GHz to 8.6 GHz, a wide bandwidth of 6.2 GHz, an impressively low insertion loss of 0.4 dB, and a return loss better than 20 dB. Furthermore, the filter is distinguished by its compact dimensions of 9 mm × 6 mm, making it an ideal choice for applications where space is limited. These results highlight the effectiveness of the genetic algorithm in designing high-performance microstrip filters while maintaining a simple and uncomplicated structure. By integrating these filters into advanced communication systems, we pave the way for more efficient communication technologies and enhanced connectivity, thereby addressing the growing demands of the telecommunications market.

### References

1. D.-C. Chang et C.-W. Hsue, « Wide-band equal-ripple filters in nonuniform transmission lines », *IEEE Transactions on Microwave Theory and Techniques*, vol. 50, no 4, p. 1114-1119, avr. 2002, doi: 10.1109/22.993414.
2. C.-Y. Hung, M.-H. Weng, R.-Y. Yang, et Y.-K. Su, « Design of the Compact Parallel Coupled Wideband Bandpass Filter With Very High Selectivity and Wide Stopband », *IEEE Microwave and Wireless Components Letters*, vol. 17, no 7, p. 510-512, juill. 2007, doi: 10.1109/LMWC.2007.899312.
3. R. Li et L. Zhu, « Compact UWB Bandpass Filter Using Stub-Loaded Multiple-Mode Resonator », *IEEE Microwave and Wireless Components Letters*, vol. 17, no 1, p. 40-42, janv. 2007, doi: 10.1109/LMWC.2006.887251.
4. V. K. Killamsetty et B. Mukherjee, « Compact Wideband Bandpass Filter for TETRA Band Applications », *IEEE Microwave and Wireless Components Letters*, vol. 27, no 7, p. 630-632, juill. 2017, doi: 10.1109/LMWC.2017.2711515.
5. C.-S. Ye, Y.-K. Su, M.-H. Weng, Hon-Kuan, et J.-J. Syu, « Design of a compact CPW bandpass filter used for UWB application », *Microwave and Optical Technology Letters*, vol. 51, p. 298-300, févr. 2009, doi: 10.1002/mop.24028.
6. Y.-C. Chang, C.-H. Kao, M.-H. Weng, et R.-Y. Yang, « Design of the Compact Wideband Bandpass Filter With Low Loss, High Selectivity and Wide Stopband », *IEEE Microwave and Wireless Components Letters*, vol. 18, no 12, p. 770-772, déc. 2008, doi: 10.1109/LMWC.2008.2007691.
7. D. Choudhary et R. Chaudhary, « A Compact Via-Less Metamaterial Wideband Bandpass Filter Using Split Circular Rings and Rectangular Stub », *Progress In Electromagnetics Research Letters*, vol. 72, p. 99-106, janv. 2018, doi: 10.2528/PIERL17092503.
8. X.-C. Ji, W.-S. Ji, L.-Y. Feng, Y.-Y. Tong, et Z.-Y. Zhang, « design of a novel multi-layer wideband bandpass filter with a notched band », *PIER Letters*, vol. 82, p. 9-16, 2019, doi: 10.2528/PIERL18121101.
9. Z. Li et K.-L. Wu, « Direct Synthesis and Design of Wideband Bandpass Filter With Composite Series and Shunt Resonators », *IEEE Transactions on Microwave Theory and Techniques*, vol. 65, no 10, p. 3789-3800, oct. 2017, doi: 10.1109/TMTT.2017.2686863.
10. X. Gao, W. Feng, et W. Che, « Compact Ultra-Wideband Bandpass Filter With Improved Upper Stopband Using Open/Shorted Stubs », *IEEE Microwave and Wireless Components Letters*, vol. 27, no 2, p. 123-125, févr. 2017, doi: 10.1109/LMWC.2016.2647385.
11. S. W. Wong et L. Zhu, « Quadruple-Mode UWB Bandpass Filter With Improved Out-of-Band Rejection », *IEEE Microwave and Wireless Components Letters*, vol. 19, no 3, p. 152-154, mars 2009, doi: 10.1109/LMWC.2009.2013735.
12. « (12) (PDF) Genetic Algorithm Based on Natural Selection Theory for Optimization Problems ». Consulté le: 13 juin 2024. [En ligne]. Disponible sur: [https://www.researchgate.net/publication/344832850\\_Genetic\\_Algorithm\\_Based\\_on\\_Natural\\_Selection\\_Theory\\_for\\_Optimization\\_Problems](https://www.researchgate.net/publication/344832850_Genetic_Algorithm_Based_on_Natural_Selection_Theory_for_Optimization_Problems)
13. K. Deb, « Multi-objective Optimisation Using Evolutionary Algorithms: An Introduction », in *Multi-objective Evolutionary Optimisation for Product Design and Manufacturing*, L. Wang, A. H. C. Ng, et K. Deb, Éd., London: Springer, 2011, p. 3-34. doi: 10.1007/978-0-85729-652-8\_1.



## Existence of solutions for a nonlinear parabolic problem

A. Bousgheiri <sup>1</sup>, A. Ourraoui <sup>2</sup>

<sup>1</sup> University Mohammed First, Faculty of sciences, AMAO, Oujda, Morocco

<sup>2</sup> University Mohammed First, Faculty of sciences, AMAO, Oujda, Morocco

### Abstract

Throughout this presentation, we primarily focus on the parabolic p-Laplacian equation:  $\partial_t u - \Delta_p u + f(x, u) = \alpha \chi_{\{u > 0\}} |u|^{-1} + g(x, \nabla u)$ , with homogeneous Dirichlet boundary condition, by using Galerkin's approach with particular estimates, we establish the local and global existence of solutions.

### References

1. A. Bousgheiri, A. Ourraoui, Note on blowup solutions for a general class of semilinear parabolic equations involving second order operator, vol. 25, 2024, pp. 165-171.
2. V. Barbu, Nonlinear Differential Equations of Monotone Types in Banach Spaces, Springer Monogr. Math., Springer, New York, 2010, doi:10.1007/978-1-4419-5542-5.
3. D.S. Clark, Generalization of an inequality of Gronwall-Reid, Journal of Approximation Theory, vol. 58, 1989, pp. 1214, DOI: 10.1016/0021-9045(89)90003-8.
4. P. Esposito, N. Ghoussoub, Y. Guo, Mathematical Analysis of Partial Differential Equations Modeling Electrostatic MEMS. Courant Lecture Notes in Mathematics, vol. 20, (2010).
5. L. C. Evans, Partial differential equations. Graduate Studies in Mathematics, 19, Amer. Math. Soc., Providence (1998).
6. A. Friedman, Partial Differential Equations of Parabolic Type, Prentice Hall, (1964).
7. V. Galaktionov, J. Vazquez, Continuation of blowup solutions of nonlinear heat equations in several space dimensions. Commun. Pure Appl. Math, vol. 50, 1997, pp. 167.
8. N. Ghoussoub, Y.J. Guo, On the partial differential equations of electrostatic MEMS devices I stationary case. SIAM J. Math. Anal. 38, 2007, pp. 1423-1449.
9. J. Giacomoni, P. Sauvy, S. Shmarey, Complete quenching for a quasilinear parabolic equation. J. Math. Anal. Appl, vol. 410, 2014, pp. 607-624.
10. T.H. Gronwall, note on the derivatives with respect to a parameter of the solutions of a system of differential equations, Ann. of Math, vol. 20, 1919, pp. 292-296.
11. Y.J. Guo, Global solutions of singular parabolic equations arising from electrostatic MEMS. J. Diff. Equ, vol. 245, 2008, pp. 809-844.
12. Y.G. Gu, Necessary and sufficient condition of extinction of solutions on parabolic equations. Acta Math. Sin, vol. 37, 1994, pp. 225-244.
13. M. Alimohammady and F. Fattahi, Existence of solutions to hemivariational inequalities involving the p(x)-Biharmonic operator, Electronic journal of differential equations, vol. 2015, Art. ID 79, 2015. [On line]. Available: <https://bit.ly/35pW9CP>.
14. L. Martinson and K. Pavlov, Unsteady shear flows of a conducting fluid with a rheological power law, Magnitnaya gidrodinamika, vol. pp. 50-58, 1971. [15] V. Zhikov, Averaging of functionals of the calculus of variations and elasticity theory, Mathematics of the USSR-Izvestiya, vol. 29, no. 1, pp. 33-36, 1987, doi: 10.1070/IM1987v029n01ABEH000958.



Email: [abdelhak1993bousgheiri@gmail.com](mailto:abdelhak1993bousgheiri@gmail.com); [a.ourraoui@gmail.com](mailto:a.ourraoui@gmail.com)

## Hybrid CNN-BiLSTM-Attention Models for Accurate Remaining Useful Life Prediction in Turbofan Engines

Abdelhafid Ayaou, Fouad Elotmani, and Mohamed Atounti

*Laboratory of MASI, FPN, Mohammed First University, Oujda, Morocco*

### Abstract

In this work, we present a hybrid deep learning model that integrates Convolutional Neural Networks (CNN), Bidirectional Long Short-Term Memory (BiLSTM) layers, and an Attention mechanism to predict the Remaining Useful Life (RUL) of turbofan engines. The model begins with feature selection using Random Forest, followed by data preprocessing steps including scaling, capping the RUL target, and splitting the data by engine to ensure the integrity of the time series. CNN layers extract spatial features from the sensor data, while BiLSTM layers capture temporal dependencies, modeling both past and future information. The Attention mechanism further enhances the model by focusing on the most important time steps, improving the accuracy of predictions. We utilize Hyperband to efficiently optimize the model architecture and its hyperparameters. The model is validated using the C-MAPSS dataset, showing strong robustness and generalization. To increase transparency, we apply SHapley Additive exPlanations (SHAP) to interpret individual predictions, providing insights into the model's decision-making process. This work offers a significant advancement in predictive maintenance for aerospace, providing a scalable and interpretable solution for real-world applications.

**Keywords:** Remaining Useful Life (RUL), Predictive Maintenance, Turbofan Engines, CNN, BiLSTM, Attention Mechanism, Feature Selection, Hyperband, SHAP, Aerospace Applications.



## Fintech and Blockchain in Morocco: A Systematic Literature Review

Oumaima Issaili <sup>1</sup>, Abdelfettah Sedqui <sup>2</sup>

<sup>1</sup>Laboratory of Innovative Technologies, National school of applied sciences, Abdelmalek Essaadi University, Tangier, Morocco

<sup>2</sup>Laboratory of Innovative Technologies, National school of applied sciences, Abdelmalek Essaadi University, Tangier, Morocco

### Abstract

This paper aims to identify, analyze and organize the literature about the applications of blockchains and fintech technology in Morocco across a various sector such as logistic, industry, finance, health, energy, government.... Using PRISMA protocol our study reviewed 26 academic papers published between 2015 and 2024. Fintech and Blockchain technology in Morocco are still in its early stage of adoption despite the growing interest received from both public and private sectors. The finding reveals that Fintech and blockchain technology can bring significant improvements in areas such as supply chain management, financial transactions, and governmental services. However, several obstacles including regulatory uncertainty, and technological infrastructure limitations remain significant challenges. The limitations of this study are represented mainly by the limited available papers specifically addressing Fintech and blockchain applications in the Moroccan context which highlighting the need for more depth research. This paper has practical implications that call Moroccan policymakers and industrial leaders to develop strategies toward using Fintech and blockchain technology while focusing on the legislative and technological barriers. By focusing on these challenges and opportunities, this review serves as a foundation for future research and encourages the development of blockchain-driven innovations in Morocco. Ultimately, the study presents important implications for both academics and practitioners to understand how Fintech and blockchain technology could influence digital revolution and part of ongoing industrial transformation in a country.

**Keywords:** Blockchain, Fintech, Morocco, digital transformation, industry 4.0, Artificial intelligence.

### References

1. I. Dakhli, A. Sedqui, M. Derrhi, et B. Karroumi, « Artificial Intelligence and Crisis Management a Systematic Literature Review using PRISMA », in *2024 4th International Conference on Innovative Research in Applied Science, Engineering and Technology (IRASET)*, FEZ, Morocco: IEEE, mai 2024, p. 1-6. doi: 10.1109/IRASET60544.2024.10549274.
2. M. M. Queiroz, R. Telles, et S. H. Bonilla, « Blockchain and supply chain management integration: a systematic review of the literature », *Supply Chain Manag. Int. J.*, vol. 25, n° 2, p. 241-254, août 2019, doi: 10.1108/SCM-03-2018-0143.
3. F. Z. Meskini et R. Aboulaich, « Insurance Based on Waqf and Blockchain Technology: A Strong Social Impact & Efficiency », *WSEAS Trans. Bus. Econ.*, vol. 21, p. 741-752, mars 2024, doi: 10.37394/23207.2024.21.62.



*Oumaima Issaili has expertise in industrial engineering and logistics, with two years of experience as a planner and one year as a stock management supervisor. Currently, she is a second-year PhD student focusing on the methodologies and methods of blockchain technology in Morocco. Her research aims to explore innovative applications of blockchain in supply chain management, bridging theoretical concepts with practical implementations to enhance efficiency and transparency in Moroccan industries*

**Email :** [oumaima.issaili@etu.uae.ac.ma](mailto:oumaima.issaili@etu.uae.ac.ma)

## Maximum Matching in Fractal Trees and Sierpiński Carpet Using Python

Abdelkarim Dahmani<sup>1</sup>, Kaoutar Lamrini Uahabi<sup>1</sup>, Siham El Habib<sup>2</sup>

<sup>1</sup> Mohammed First University, FPN, Nador, 62000, Maroc.

<sup>2</sup> Mohammed First University, FSO, Oujda, 60000, Maroc.

### Abstract

The role of this paper is to evaluate the process of calculating the maximum matching cardinality in the Fractal Graph, specifically focusing on Fractal Trees and Sierpiński Carpet. In this analysis, we delve into the characteristics, construction, properties, nature, implementation, iteration, and applications of renowned fractal graphs such as the Fractal Trees and Sierpiński Carpet. The use of Python programming language is employed to validate the results comprehensively. Here, we elucidate the construction and implementation of Fractal Graphs, employing the proof of mathematical induction methods to establish their properties and behaviors. The practical applications of the maximum matching cardinality value span various domains, encompassing construction, computer architecture design, camera focusing, and optimization of raw material consumption at construction sites, among others.

### References

1. West, D. B. (2001). Introduction to Graph Theory. Upper Saddle River: Prentice Hall.
2. Falconer K.J, (1985), The geometry of Fractal Sets, Cambridge University Press, Cambridge
3. Jungnickel, D. (2005). Graphs, Networks and Algorithms. Berlin: Springer.
4. Tharaniya, P.,Jayalalitha,G. (2019). Maximum matching in fractal graph.
5. Zaslavsky, T., (2012). A mathematical bibliography of signed and gain graphs and allied areas.
6. Deo, N., (2017). Graph theory with applications to engineering and computer science.



*Abdelkarim Dahmani* have extensive expertise in the field of partial differential equations, with a particular focus on fractals. Over the years, I have conducted in-depth research and analysis on the application of fractals within this domain. In addition to my research experience, I have more than six years of teaching mathematics, where I have successfully instructed students at various levels and helped them grasp complex mathematical concepts.

**Email:** Abdelkarim.dahmani @ump.ac.ma

## Transformation of GED functionalities from the CIM to the PIM via the QVT code

Soufiane Hakkou<sup>1</sup>, Redouane Esbai<sup>2</sup>, Lamlili El mazoui nadori Yasser<sup>3</sup>

<sup>1</sup> MASI laboratory ,Pluridisciplinary faculty of nador, Mohammed the 1st University, Nador, Morocco

<sup>2</sup> MASI laboratory ,Pluridisciplinary faculty of nador, Mohammed the 1st University, Nador, Morocco

<sup>3</sup> MATSI Laboratory, Mohammed the 1st University, Oujda, Morocco

### Abstract

This article explores the scanning functionality in electronic document management (EDM) and its representation in the Business Process Model and Notation (BPMN). Digitization facilitates the conversion of paper documents into digital formats, improving storage and access to information. From this BPMN representation, the article describes the transformation process into a UML class diagram using the Model-Driven Architecture (MDA) approach. This method structures development into three levels, facilitating maintenance and system adaptability. The QVT transformation language is also introduced to define mapping rules between BPMN and UML elements, ensuring a smooth transition and efficient integration of GED systems.

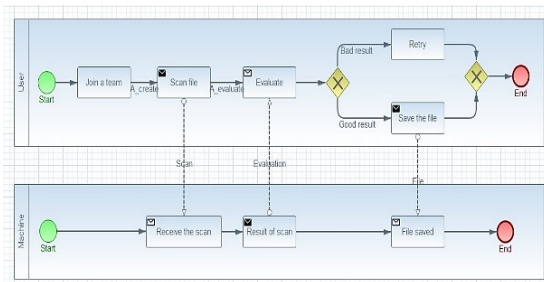

Fig: Representation in bpmn

### References

1. Fangyu Guo, Charles T. Jahren and Yelda Turkan, Electronic Document Management Systems for the Transportation Construction Industry, *International Journal of Construction Education and Research*, (2021), 52-67.
2. Kurganova M.V. Enterprise Knowledge Base Based on EDM System. In: *Ashmarina S.I., Horak J., Vrbka J., Suler P. (eds) Economic Systems in the New Era: Stable Systems in an Unstable World. IES 2020. Lecture Notes in Networks and Systems, vol 160*, (2021).
3. Chinosi, Michele and Michele, and Trombetta, Alberto and Alberto., BPMN: An introduction to the standard. *Computer Standards and Interfaces*, (2011).
4. Colomb R. et al, The Object Management Group Ontology Definition Metamodel. In: *Calero C., Ruiz F., Piattini M. (eds) Ontologies for Software Engineering and Software Technology*,(2006).



I am currently a PhD student at the MASI Laboratory, where my research focuses mainly on model-driven architecture (MDA), model transformation and software development automation. My work is part of a thesis on the application of the MDA approach in GED. In the context of my research, I am particularly interested in issues of automatic code generation, modeling complex systems, etc.

**Email:** soufianehakkou@ump.ac.ma



## Comparison between Trajectory Planning Algorithms for Mobile Robots

Kawthar Touzani, Abdelkader Youssefi

Research Laboratory of Engineering, Industrial Management, and Innovation, Faculty of Science and Technology Settat

### Abstract

Trajectory planning algorithms, used in robotics to avoid obstacles, are divided into two categories: classical and artificial intelligence (AI)-based. Classical algorithms, such as A\*, Dijkstra, RRT, and PRM, follow predefined rules and are effective in simple environments. AI-based algorithms, like Q-learning, learn to adapt to more complex environments.

The study compares these approaches through various simulations (simple, complex, and dynamic environments). The goal is to evaluate their efficiency and adaptability in different planning scenarios, highlighting the contexts where each algorithm excels or fails. The results highlight the strengths and limitations of each algorithm. Classical algorithms showed strong performance in terms of optimality in static environments, while AI-based algorithms stood out in dynamic scenarios.

Finally, future work aims to explore hybrid combinations of classical and AI-based algorithms to maximize their advantages.

**Keywords:** Trajectory planning, algorithms, mobile robot, artificial intelligence, performance evaluation.

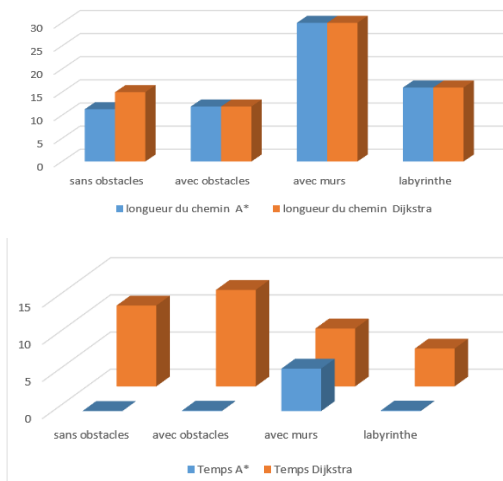

**Fig:** Comparison of the A algorithm in different scenarios in terms of path length and time

### References

1. A. Smith, "Trajectory Planning for Mobile Robots: A Comparative Study," International Journal of Robotics Research.
2. B. Johnson and C. Lee, "Optimization Techniques in Mobile Robot Path Planning," IEEE Transactions on Robotics.
3. D. Williams, "A Survey on Motion Planning Algorithms for Autonomous Systems," Journal of Automation and Robotics.
4. M. Gupta and E. Rogers, "Comparative Analysis of Heuristic-Based and Graph-Based Trajectory Planning," Robotics and Autonomous System



Author has expertise in electrical systems, embedded systems, robotics, trajectory planning, mobile robots, artificial intelligence, algorithm development and autonomous navigation.

**Email:** touzani.kaw.fst@uhp.ac.ma

## Characteristics Analysis of a Negative Permittivity Metamaterial Transmission Line Equivalent to a Microwave Circuit

Ikram Hamdaoui<sup>1</sup>, Mimoun El-Aouni<sup>1</sup>, Youssef Ben-Ali<sup>1,2</sup>, Amina Ghadban<sup>1</sup>, Driss Briat<sup>1</sup>

<sup>1</sup>Laboratory of Materials, Waves, Energy and Environment, Team of Waves, Acoustics, Photonics and Materials, Mohamed I University, Oujda, Morocco.

<sup>2</sup>Engineering Sciences Laboratory (LSI), Multidisciplinary Faculty of Taza, Sidi Mohamed Ben Abdellah University, B.P. 1223, Taza Gare, Morocco.

### Abstract

We carry out an in-depth theoretical and numerical study of microwave propagation in a basic unit cell of a transmission line (TL) placed between two substrates. We consider that our basic system is formed by a segment of a right-handed material (RHM medium), grafted with a lateral resonator made of metallic wires (TW) possessing negative permittivity (ENG meta-material). We approximate the basic system by a unit cell equivalent to an electrical circuit, consisting of resistors R, capacitors C and coils L. We use the transfer matrix method (TMM) to obtain the transmission and reflection rates of an electromagnetic wave as a function of electrical impedance "Z" and electromagnetic parameters " $\epsilon$  and  $\mu$ ", and then simulate them using the FORTRAN program. Our numerical results indicate that transmission and reflection rates are influenced and controlled by the geometric and electrical parameters of the ENG meta-material. Consequently, these parameters must be carefully selected according to the application in question in order to obtain meaningful electromagnetic filtering results.

**Keywords:** Electromagnetic wave, Meta-materials, Transmission line (TL), Electric circuit, Transmission rate, Reflection rate.

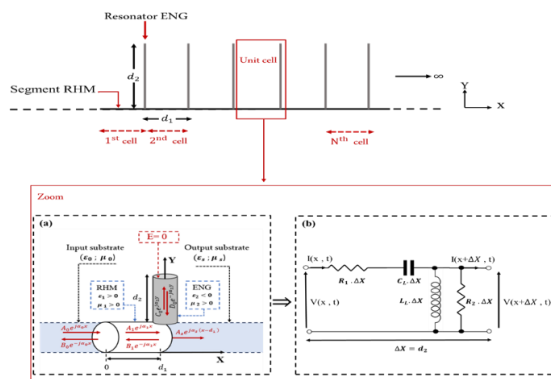

**Figure: Schematic representation of a basic unit cell of the transmission line (TL).**

### References

- Caloz, C., & Itoh, T. (2002). Application of the transmission line theory of left-handed (LH) materials to the realization of a microstrip" LH line". In IEEE Antennas and Propagation Society International Symposium (IEEE Cat. No. 02CH37313) (Vol. 2, pp. 412-415).
- Eleftheriades, G. V., Iyer, A. K., & Kremer, P. C. (2002). Planar negative refractive index media using periodically LC loaded transmission lines. IEEE transactions on Microwave Theory and Techniques, 50(12), 2702-2712.
- Caloz, C., and Itoh, T., (2003) .Novel microwave devices and structures based on the transmission line approach of meta-materials., in IEEE MTT-S Int.Symp., Philadelphia, PA, pp. 195–198.
- Zhang, L., Wang, Z., Chen, H., Li, H., & Zhang, Y. (2008). Experimental study of quasi-one-dimensional comb-like photonic crystals containing left-handed material. Optics communications, 281(14), 3681-3685.



I'm a physics specialist with a master's degree in optics and materials from the Université Mohammed First -Oujda in 2024. My research, carried out at the Materials, Waves, Energy and Environment Laboratory "LaMon2E", within the team specializing in Waves, Acoustics, Photonics and Materials, focuses on meta-materials, in particular filtering using transmission lines. I have submitted a scientific article in the journal "Optical Memory and Neural Networks" on this subject, which is in line with my PhD projects, where I plan to pursue research on filtering and detection based on periodic/quasi-periodic systems to improve metamaterial-based technologies.

**Email:** [etudiante.master2024@gmail.com](mailto:etudiante.master2024@gmail.com)

## Ephemeral Diffie-Hellman Key Exchange: An Innovative Approach for IoT

Mohamed El Ouafi, Kaoutar Lamrini Uahabi, Abderrahim Aslimani

Mohammed First University, FPN, Nador, 62000, Maroc.

### Abstract

Ephemeral key exchange is a fundamental pillar of modern cryptography, providing enhanced security through the property of forward secrecy. The Ephemeral Diffie-Hellman (ECDHE) algorithm allows for the generation of temporary keys for each communication session, ensuring that even if a private key is compromised, previous sessions remain protected. This method is essential for security protocols such as TLS and VPNs, where confidentiality and security are paramount.

However, with the advent of quantum computers, traditional Diffie-Hellman methods are vulnerable to quantum attacks, especially for low-performance devices like those in the Internet of Things (IoT). To address this challenge, we have introduced a powerful and secure interactive structure based on a new problem derived from Diffie-Hellman. This structure uses changing random elements to withstand the quantum computing capabilities of adversaries. By formulating the underlying computational problems within a robust complexity framework, we demonstrate that our scheme is secure, provided that the new Diffie-Hellman problem is sufficiently difficult to solve.

### References

5. Polk, Tim; McKay, Kerry; Chokhani, Santosh (April 2014). Guidelines for the Selection, Configuration, and Use of Transport Layer Security (TLS) Implementations
7. Diffie, W., & Hellman, M. E. (2022). New directions in cryptography.
8. Bernstein, Daniel J. (2009) "Introduction to post-quantum cryptography".
9. Canetti, Ran; Halevi, Shai; Katz, Jonathan (2003). "A Forward-Secure Public-Key Encryption Scheme"



*I have a good experience in cryptography and security systems, especially in their theoretical and mathematical aspects, such as the fundamental mathematical problems on which cryptography is based. In addition to my research experience, I have over 7 years of experience teaching mathematics to students at various levels, where I have successfully trained them and helped them build their knowledge in mathematics.*

**Email:** mohamed.elouafi10@ump.ac.ma

## Truck Position Prediction in Port Terminals Using Temporal Convolutional Networks

Mohammed El Karkraoui, Hicham Attariuas

*The Faculty of Sciences, Tetouan, Morocco*

### Abstract

Managing truck fleets in port terminals is complicated by frequent GPS signal disruptions and network failures, leading to incomplete tracking data. This study explores the use of Temporal Convolutional Networks (TCN) for predicting truck positions in the absence of reliable GPS signals. TCN, known for its ability to capture long-range dependencies in time series data, is applied to learn movement patterns from truck position history. To optimize prediction accuracy, the study transforms National Marine Electronics Association (NMEA) GPS data from 31 trucks into a local Cartesian reference frame, which allows for more robust processing of spatial coordinates. The transformed data is processed into time-series sequences, which are then used as input for the TCN model. The results demonstrate that TCN outperforms traditional Recurrent Neural Network (RNN) architectures, providing a more accurate and computationally efficient solution for truck position prediction. This approach holds significant promise for improving fleet management and operational efficiency in port terminals. Future research could explore incorporating additional sensor data and extending the system to larger fleets and more complex operational scenarios.

**Keywords:** Position Prediction, TCN, Time Series, GPS data.



*Author has expertise in Machine Learning, Deep Learning, GPS data.*

**Email:** mohamed.karkraoui@gmail.com

---

## Study and development of multi-band fractal triangular patch antenna for WLAN application

Safae Dou-allal<sup>1</sup>, Ahmed Faize<sup>2</sup>, Soufian Lkritt<sup>2</sup>

<sup>1</sup>Mathematics and Information Systems Laboratory, FP of Nador, Mohammed First University, Oujda, Morocco

<sup>2</sup>Mathematics and Information Systems Laboratory, EST of Nador, Mohammed First University, Oujda, Morocco

### Abstract

In this paper, a novel design of a multi-band fractal antenna is proposed for WLAN applications. The antenna structure is based on a triangular-shaped resonator that incorporates a triangle-shaped slot. This initial triangular configuration serves as the foundation for developing a fractal rhombic patch design. Specifically, this triangular slot is integrated at each center side of the rhombic patch antenna to enhance the antenna's performance and enable multi-band functionality.

To further optimize the antenna's adaptation and improve its operational efficiency, modifications are made to the shape of the slot located on the ground plane. These modifications are carefully analyzed to observe their impact on the antenna's performance. The step-by-step development of the antenna, including its different design stages and variations in its dimensions, is comprehensively compared. The results are demonstrated through the reflection coefficient curve, which visually represents the antenna's performance across different frequency bands.

The entire design process of the proposed antenna is meticulously planned and simulated using the CST Microwave Studio (CST MS) software. This powerful electromagnetic simulation tool allows for accurate modeling of the antenna's behavior, enabling the identification of key parameters that influence the performance. The simulation results illustrate how the fractal design and slot modifications contribute to achieving the desired multi-band characteristics, making this antenna suitable for efficient WLAN operations.

With its innovative design and optimization, the proposed antenna presents a significant advancement in multi-band fractal antenna technology, offering potential applications in various wireless communication systems, particularly in WLAN.



## Transforming COBOL Legacy Systems to Cloud-Native Architectures: An ADM and QVT-Driven Approach

Fouad Elotmani, Abdelhafid Ayaou, and Mohamed Atounti

<sup>1</sup>Laboratory of Applied Mathematics and Information Systems, Higher School of Technology of Nador, Mohammed Premier University, Oujda. – Morocco

### Abstract

This is the growing issue of modernizing the existing and predominantly used mainframe systems as organizations perform the transition towards cloud-native models. In response to this problem, Architecture-Driven Modernization (ADM) in conjunction with the Object Management Group (OMG) standards provide a sound approach to the problem. This paper focuses on using QVT-based transformation within ADM when migrating from a legacy COBOL mainframe system to cloud-native. It makes it possible to preserve business logic as well as make it possible to support modern distributed technologies. In this paper, by giving a detailed example, we show how our approach brings some aspects of a COBOL application into a microservices-style architecture running on a cloud platform and following the KDM and UAF. In the present context, our integrated QVT-based approach provides an effective way of gathering and transforming the legacy code and data into microservices, facilitating a structural and functional congruity with the cloud milieu. The findings show a reduction of migration work complexity and enhancement of the system flexibility and expandability. This case study points to the ability of OMG-compliant ADM methodologies to address legacy-to-cloud transformations, demonstrating the effectiveness and flexibility of structured QVT transformation for large-scale enterprise modernization.

**Keywords:** Mainframe Modernization, Cloud Native Migration, QVT Transformation, Legacy COBOL, Microservices Architecture, Enterprise Modernization



Email: [f.elotmani@ump.ac.ma](mailto:f.elotmani@ump.ac.ma)

---



## Characterizing Temperature Distribution in Bifacial PV Modules Using Integrated Heating, Absorption Analysis, and Numerical Techniques

Khadija Ibaararen, Mhammed Zaimi, Khadija El Ainaoui, El Mahdi Assaid

Laboratory of Instrumentation of Measure and Control, Department of Physics, Faculty of Sciences, Chouaib Doukkali University (UCD), P. O. Box 20 El Jadida, Morocco

### Abstract

This study delves into the complex dynamics of heat transfer within bifacial photovoltaic (bPV) solar modules subjected to spectral solar illumination. A novel model is developed to integrate internal heating mechanisms with optical absorption, based on equations governing the interaction between light and matter within the multi-layered structure of the bPV module. The analysis considers reflection and transmission at each interface between adjacent layers, as well as absorption within each layer. The dielectric properties of these interfaces are utilized to compute wavelength-dependent reflectance and transmittance. Furthermore, the optical properties of each layer are employed to ascertain absorption coefficients and internal heat sources based on the direction of irradiance, considering both the top and bottom faces of the module. This study explores the effect of irradiance reflection on temperature profiles. Additionally, it evaluates the impact of different materials placed beneath the bPV module and examines how albedo influences thermal performance. The heat equation is solved under dynamic conditions using a 1-D finite difference (FD) method, revealing detailed temperature profiles under Standard Test Conditions (STC), Normal Operating Cell Temperature (NOCT), and real-world conditions.

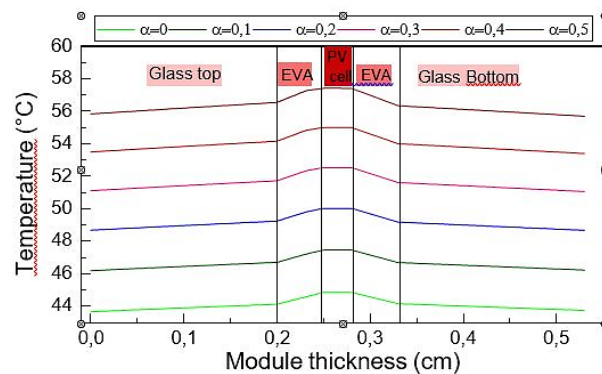

**Fig: Temperature profiles within the multilayered structure of a bPV module for various albedo coefficients**



Author has expertise in studying the behavior of temperature profiles within multilayer structures of different photovoltaic (PV) module technologies. Moreover determining the temperature profile in PV modules under various conditions using different numerical methods to compare the obtained results.

**Email:** Ibaararen.khadija@ucd.ac.ma

## Empowering Legacy Systems with ADM and QVT: A Structured Transformation Approach Across Heterogeneous Platforms

Fouad Elotmani, Abdelhafid Ayaou, and Mohamed Atounti

<sup>1</sup>Laboratory of Applied Mathematics and Information Systems, Higher School of Technology of Nador, Mohammed Premier University, Oujda. – Morocco

### Abstract

To find out the interventions that have to be made to upgrade a legacy system to leverage new technologies while retaining core competencies, the following research questions are pivotal. Legacy system modernization is inevitable for organizations wanting to leverage new technologies and at the same time, protect business logic that is regarded as strategic. Architecture-Driven Modernization (ADM), especially in cases dealt with OMG standards, offer clear guidance to overcome all the described challenges. This paper therefore presents a model transformation framework derived from ADM that uses the QVT language in a migration between two different technologies. The approach is targeted on preserving the continuity of architectural components which constitute an important prerequisite for system integration in dynamically changing IT environments. To support this framework, the case study is provided to show how a monolithic Java EE application is migrated to a modern microservice .NET application. Following the OMG KDM and UAF specifications, the system's architecture analysis and transformation adhere to specifications. This research shows that our QVT-based approach involves less complexities in migration because transformations are realized in a structural manner and promote the assimilation of business processes with IT systems. The implications witnessed in the study endorse the potential of OMG-compliant ADM and QVT in performing scalable, prognosis-considerate transformation on different platforms as established by recent endeavors in ADM and model-based system engineering.

**Keywords:** Legacy Modernization, Architecture Driven Modernization (ADM), QVT Transformation, OMG Standards, Microservices Migration, Model Based Engineering, System Integration



*Email : f.elotmani@ump.ac.ma*

---

## Metasurface-Enhanced Reconfiguration of MIMO Antenna Radiation Patterns for 5G Millimeter-Wave Applications

Youssef El Maimouni<sup>1</sup>, Saida Ahyoud<sup>1</sup>, Abdelmoumen Kaabal<sup>2</sup>

<sup>1</sup> TIMS, FS, Abdelmalek Essaadi University, Tetouan, Morocco

<sup>2</sup> SATSIER, FSTH, Abdelmalek Essaadi University, Tetouan, Morocco

### Abstract

The rapid advancement of telecommunications technology, particularly with the advent of 5G, represents a transformative shift in wireless communications. Central to this evolution is the utilization of millimeter-wave frequencies, which provide substantial bandwidth but also present significant challenges in optimizing antenna performance. One key challenge is reconfiguring antenna radiation patterns to enhance performance.

In this study, we present a novel approach to reconfiguring MIMO antenna radiation patterns by employing metasurfaces. Unlike other techniques, such as diodes<sup>1,2</sup> and RF MEMS<sup>3</sup>, metasurfaces offer exceptional capabilities for manipulating electromagnetic waves. Our method involves utilizing metasurfaces composed of split-ring resonators arranged in a grid, which facilitates beam steering and improves antenna gain. Specifically, our approach enhances the gain between MIMO elements by 2.18 dB and allows for dynamic beam steering through the rotation of metasurfaces around the antenna's center.

The antenna design and analysis were conducted using CST Microwave Studio simulation software. The results demonstrate a reflection coefficient of -45.73 dB at 38.4 GHz, a bandwidth of 40.36% (spanning from 35.3 to 47.65 GHz), and a peak gain of 7.64 dB. This innovative use of metasurfaces marks a significant advancement in optimizing MIMO antenna performance for 5G millimeter-wave application.

### References

1. F. Rahmani, N. Amar Touhami, A. Belbachir Kchairi, N. Aknin, et N. Taher, « Pattern Reconfigurable Antenna for VANET, Wi-Fi, and WiMAX Wireless Communication Systems », *International Journal of Antennas and Propagation*, vol. 2021, p. 1-12, oct. 2021, doi: 10.1155/2021/9973839.
2. B.-J. Liu, J.-H. Qiu, C.-L. Wang, et G.-Q. Li, « Pattern-Reconfigurable Cylindrical Dielectric Resonator Antenna Based on Parasitic Elements », *IEEE Access*, vol. 5, p. 25584-25590, 2017, doi: 10.1109/ACCESS.2017.2771296.
3. Y.-F. Cheng, X. Ding, B.-Z. Wang, et W. Shao, « An Azimuth-Pattern-Reconfigurable Antenna With Enhanced Gain and Front-to-Back Ratio », *IEEE Antennas and Wireless Propagation Letters*, vol. 16, p. 2303-2306, 2017, doi: 10.1109/LAWP.2017.2715373.



*Youssef El Maimouni is a doctoral candidate in Electronics and Telecommunications at AbdelmalekEssaadi University in Tetouan, Morocco. He received his bachelor's and master's degrees in Electronics and Telecommunications from the Faculty of Science at the same university in 2014 and 2020, respectively. He is now conducting research at the Information Technology and System Modeling Laboratory. His research interests focus on antennas and propagation, aiming to enhance the performance and adaptability of antennas in modern telecommunications systems.*

**Email:** [youssef.elmaimouni@etu.uae.ac.ma](mailto:youssef.elmaimouni@etu.uae.ac.ma)

ID :96

## New Approach to Study the Motion of Free-Falling Objects Using Arduino and Computer

R ESSAADAOU<sup>1</sup>, M EL HADI<sup>1</sup>, A OUARIACH<sup>1</sup>, A HACHMI<sup>1</sup>, A EL MOUSSAOUY<sup>1,2</sup>, K LAABIDI<sup>1</sup>

<sup>1</sup> OAPM group, Laboratory of Materials, Waves, Energy and Environment, Department of Physics, Faculty of Sciences, Mohammed I University, Oujda 60000, Morocco

<sup>2</sup> The Laboratory of Innovation in Science, Technology and Education, Regional Center for the Professions of Education and Training, 60000, Oujda, Morocco.

### Abstract

In this paper, we have described an approach to facilitate the didactic transposition of free fall concept for 12th grade students. We also presented the experimental results obtained using an educational and experimental device developed in our laboratory, implemented through a free hardware platform Arduino to collect data from the free fall experiment. In addition, we have tested the students' satisfaction with this new device. We believe that the device presented can play a very important role in teaching the concept of free fall and bring benefit to the physics laboratory due to its high precision and reliability of measurements.

**Keywords:** LDR sensors; Red diode laser; Free fall; Physics education

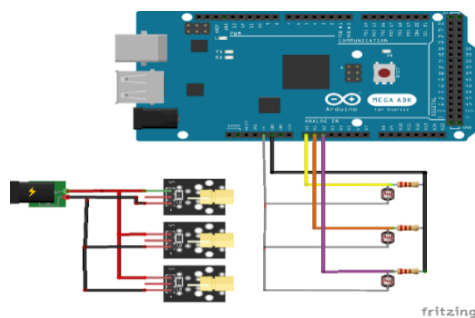

### References

1. Palmer D 2001 Students' alternative conceptions and scientifically acceptable conceptions about gravity International Journal of Science Education 23(7) 691-706.
2. Stylos G, Evangelaki G A, &Kotsis K T 2010. Misconceptions on classical mechanics by freshman university students: A case study in a Physics Department in Greece Themes in Science and Technology Education 1(2) 157-177.
3. Mchunu, S P, Imenda, S 2012 The alternative conceptions held by high school students in mechanics Science in Society 4(1) 25-42.
4. GALILI, I. 1993 Weight and gravity: teachers' ambiguity and students' confusion about the concepts. International journal of science éducation, vol. 15, no 2, p. 149-162.
5. El Moussaouy A, El Hadi M, Ouariach A, Essaadaoui R, Bria D and Laabidi K 2020 Simple Conception of Photoresistor Cell Current-Voltage Characteristic measurement Arduino-based Platform for Educational Purposes Advances in Intelligent Systems and Computing 1266348-356 doi: 10.1007/978-3-030-57799-5\_36

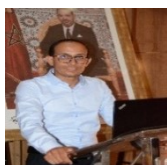

*Rachid ESSAADAOU received his PhD degree in physics and teaching science from Mohammed First University, Oujda Morocco.*

*His current research interests include teaching physics using new technology such as Arduino and mobile e-learning*

*Email: [essaadaoui.rachid@ump.ac.ma](mailto:essaadaoui.rachid@ump.ac.ma)*

## Solving Kortweg-de Vries Equation using finite difference scheme

Mustapha Bassour

Faculty of Legal, Economic and Social Sciences of Mohammedia Hassan II University of Casablanca, Morocco

### Abstract

The Korteweg-de Vries (KdV) equation is a partial differential equation that presents a mathematical model for waves on shallow water surfaces. The Korteweg-de Vries equation can thus model the motion of the water surface and more particularly the motion of low-amplitude waves in shallow water without transverse effect. By adding together all the quantities, this equation is written as

$$u_t + 3(u^2)_x + u_{xxx} = 0 \quad \text{for } t > 0 \text{ and } x \in \mathbb{R}$$

Such that  $t$  corresponds to the time variable and  $x$  corresponds to the spatial variable. We use the finite difference scheme method to solve the modified Korteweg-de Vries (KdV) equation. We develop a scheme to obtain the numerical solution of the KdV equation with initial conditions. We compare the numerical solutions obtained by this scheme with other published results to show the reliability of the schemes considered. We analyze the schemes by their accuracy and stability. We use the exact solution and conserved quantities to show the efficiency of the found schemes. The KdV equation is used in several fields, among these fields the modeling of water wave propagation and hydrodynamic waves. We present numerical schemes for the KdV equation using the finite difference approximation and the trapezoidal midpoint rule. All methods used have high accuracy in finding the solution, and the diagrams are stable. We give numerical examples.

### References

1. Shen, J., Wang, X.P. and Sun, Z.-Z. (2020) The Conservation and Convergence of Two Finite Difference Schemes for KdV Equations with Initial and Boundary Conditions. *Numerical Mathematics : Theory , Methods and Applications* , 13, 253-280.
2. Raslan, K.R. and Baghdady, H.A. (2014) New Algorithm for Solving the Modified Korteweg-de Vries (mKdV) Equation. *International Journal of Research and Reviews in Applied Sciences* , 18, 59-64.
3. J. Pang, C.-Q. Bian and L. Chao, "A New Auxiliary Equation Method for Finding Traveling Wave Solution to KdV Equation," *Applied Mathematics and Mechanics (English Edition)*, Vol. 31, No. 7, 2010, pp. 929-936.
4. F. L. Qu and W. Q. Wang, "Alternating Segment Explicit-Implicit Scheme for Nonlinear Third-Order KdV Equation," *Applied Mathematics and Mechanics*, Vol. 28, No. 7, 2007, pp. 973-980.



Email: [musbassour@gmail.com](mailto:musbassour@gmail.com)

## Design and EM Simulation of a Wideband 10 W Class F GaN Power Amplifier

Fouad Zazdi<sup>1</sup>, Said El Khaldi<sup>2</sup>, and Taj-Eddin Elhamadi<sup>1</sup>

<sup>1</sup>Faculty of Science Abdelmalek Essaadi University, BP.2121 M'Hannech II, 93030 Tetouan, – Morocco

<sup>2</sup>Experimentation and Modeling in Mechanics and Energy Systems, National School of Applied Sciences Abdelmalek Essaadi University, Al Hoceima, – Moroc

### Abstract

Current wireless communication technologies cover a wide frequency range, but existing power amplifiers may not be efficient across this extended range. This paper proposes a new structure and an enhanced design method to achieve wideband power amplifiers. The main challenge is managing harmonic frequencies that overlap with fundamental frequencies. To address this issue, a modified class-F approach is utilized. This new method simplifies the design of matching networks and achieves wide bandwidth using only three fundamental frequency points. A power amplifier based on this approach was designed, demonstrating a bandwidth of 100% from 0.6 to 2 GHz, with a drain efficiency exceeding 75% and an output power exceeding 42 dBm.

**Keywords:** Power amplifier, Wideband, Harmonic tuning, Class, F, Matching network, Wireless communication, Efficiency, Broadband, Frequency range, Design methodology



*Email : s.elkhaldi@uae.ac.ma*

*Email : telhamadi@uae.ac.ma*

---



ID : 120

## Enhancing Used Car Price Prediction in Morocco with Machine Learning: SHAP-Based Interpretability and Model Monitoring

Abdelhafid Ayaou, Fouad Elotmani, and Mohamed Atounti

*Laboratory of MASI, FPN, Mohammed First University, Oujda. – Morocco*

### Abstract

Predicting used car prices is a challenging task due to the many factors that affect vehicle valuation. This study presents a complete machine learning approach to build an accurate prediction model for the Moroccan market. Data was collected from a local car sales website using web scraping, followed by thorough preprocessing, including data cleaning, encoding, scaling, and handling outliers. Among the evaluated machine learning algorithms, the CatBoost regressor emerged as the top performer, achieving an R2 score of 91.35%, demonstrating strong predictive accuracy. To gain insights into the factors influencing predictions, SHAP (SHapley Additive exPlanations) was employed, revealing key features such as mileage, manufacturing year, and engine power as the most impactful on price estimations. The final model was deployed in a user-friendly web application that offers market analysis visualizations, generates predictions with interpretable results using SHAP, and includes model monitoring to track data drift and facilitate easy retraining. This practical tool enables consumers and businesses to make informed pricing decisions and stay updated with market trends.

**Keywords:** Used Car Price Prediction, Machine Learning, CatBoost, SHAP, Interpretability, Web Application, Morocco



## Application of Neural Networks for the Optimization of a Discrete Probabilistic Model of a Physical Quantity Degradable by a Continuous Model

Imad El Adraoui<sup>1</sup>, Youssef Jabari<sup>2</sup>, Brahim Moudoud<sup>3</sup>, Hassan Gziri<sup>2</sup>

<sup>1</sup>Materials, Systems and Energy Engineering Laboratory (MaSEEL). Faculty of Sciences and Technology, Abdelmalek Essaâdi University, Tangier, Morocco

<sup>2</sup>Laboratory of Engineering, Industrial Management, and Innovation (IMII). Faculty of Sciences and Technology, Hassan 1<sup>st</sup> University, Settat, Morocco

<sup>3</sup>Research team: Automatic and Energy Conversion (AEC). Faculty of Sciences and Technology, Sultan Moulay Slimane University, Beni Mellal, Morocco

### Abstract

Optimization in the context of physical problems, particularly at a high level of resolution, is a relatively new challenge faced by various fields. To address this, neural network-based methods have emerged as powerful tools for reducing errors and improving performance. This article presents an optimization approach that leverages the capabilities of neural networks. The proposed method focuses on designing an architecture that optimizes a discrete model (specifically, the volume flow of a pump) in conjunction with a continuous model that closely aligns with the underlying physical phenomenon. The architecture is structured as a multi-layer neural network, where its primary function is to process data related to a degradable physical quantity using a staircase model. This processing helps establish a relationship between the input and output variables of the system. The identification of this relationship is facilitated through automatic data learning, with the function being embedded within the network's internal architecture, represented by matrices that enable the necessary correlations to be made. The results obtained demonstrate strong performance, validating the choice of the adopted neural network-based technique. This performance not only confirms the effectiveness of the optimization method but also highlights the practical applicability of the continuous model in a wide range of health monitoring systems for equipment. By optimizing data processing and analysis, this approach makes the continuous model more reliable and useful in real-world scenarios, especially for the effective monitoring and maintenance of mechanical and physical systems.

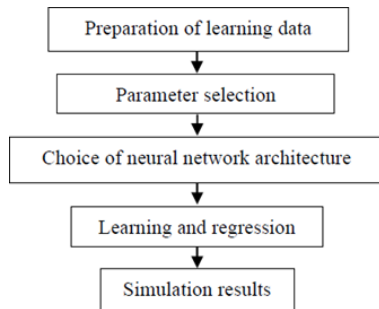

Fig 1: Methodology adopted for the optimization of the discrete model

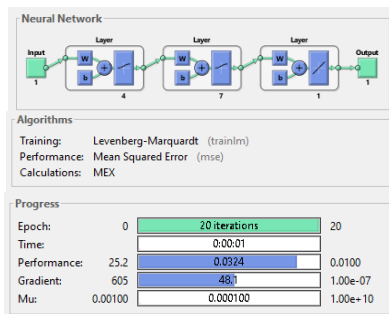

Fig 2: Learning by the neural network: (a), Neural network used; (b), Algorithms used; (c), Progress training

### Reference

- S.B, Adam, "Hybrid decision trees," Mathematics Book, University of Sherbrooke, pp. 34–58, 2012.
- H, Koivo, "Artificial neural networks in fault diagnosis and control, Control Engineering Practice," vol. 2, pp. 89- 101, 1994.
- T. Tomohiro, and S. Michio, "Fuzzy identification of systems and its applications to modeling and control," IEEE Transactions on Systems, Man, and Cybernetics, Volume: SMC-15, Issue: 1, (Jan.-Feb. 1985).
- A. Bellat, K. Mansouri, A Raihani, "Implementation of Artificial Neural Network for Optimization of a Wind Farm," IJTPE, Vol. 13, Issue. 47, No. 2, pp. 35-39, Jun 2021.
- S. Tao, Q. Xu, A. Feijoo, G. Zheng, J. Zhou, "Nonuniform Wind Farm Layout Optimization: A Stateof-the-Art Review," Energy, Vol. 209, 2020.
- S. Li, "Wind Power Prediction Using Recurrent Multilayer Perceptron Neural Networks," IEEE Power Eng. Soc. Gen. Meet. Conf. Proc., Vol. 4, pp. 2325-2330, 2003
- I. El Adraoui, H. Gziri, and A. Mousrij, Prognosis of a Degradable Hydraulic System: Application on a Centrifugal Pump, International Journal of Prognostics and Health Management, Vol. 11 (2) 013, pages. 11, 2020.
- L. Qianjun, M. Guijun, C. Cheng, "Data Fusion Generative Adversarial Network for Multi-Class Imbalanced Fault Diagnosis of Rotating Machinery," IEEE Access, vol. 8, 2020, DOI: 10.1109/ACCESS.2020.2986356.
- M. Fatima and S. Hamid, "Comparison of RBF network classification methods: MLP and RVFLNN," Damascus University Journal, Vol. (25)-No. (2), 2009.
- J. W. Park, R. Harley, G. Venayagamoorthy, "Comparison of MLP and RBF neural networks using deviation signals for on-line identification of a synchronous generator," IEEE Power Engineering Society Winter Meeting. Conference Proceedings (Cat. No.02CH37309), 2002, DOI: 10.1109/PESW.2002.984998
- G. Mustafaraja, G. Lowryb, J. Chena. "Prediction of room temperature and relative humidity by autoregressive linear and nonlinear neural network models for an open office," Energy and Buildings, Vol. 43, Issue 6, pp. 1452-1460, June 2011.

**Table 1: Values of the degradable physical parameter over different intervals**

Test	t(s)	Qv(l/s)
1	[0;300[	5
2	[300;500[	4.7
3	[500;700[	4.35
4	[700;750[	4.25
5	[750;1000[	4
6	[1000;1400[	3.5
7	[1400;1500[	3.1
8	[1500;2000[	2.85
9	[2000;2150[	2.45
10	[2150;2500[	2.25
11	[2500;2600[	2.2
12	[2600;2800[	2
13	[2800;3000[	1.5
14	[3000;3250[	1
15	[3250;3400[	0.6
16	[3400;3500[	0.4
17	[3500;3650[	0.1

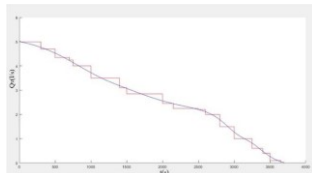

**Fig 3: Result of the optimized model**

**Table 2: Performance of the established neural network**

Performance	Value
MSE	0.03239
R	0.99323
Mu	0.00010

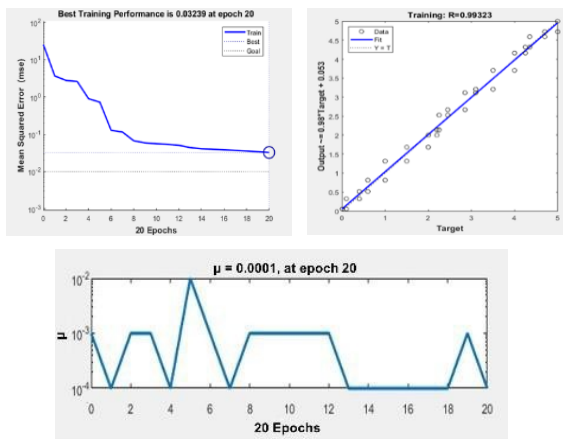

**Fig 4: Performance of model: (a), Mean squared error (MSE); (b), Correlation coefficient R. (c), Coefficient of learning  $\mu$**

12. Z. Benizza, A. Mouhsen, E. Jarmouni, "ANNs Based Unit for Power Control in a Micro Data Center," International Journal of Engineering Trends and Technology, Vol. 69, pp.56-10, 2021.
13. F. B. Hamzah, F. M. Hamzah, S. F. M. Razali, J. Zainudin, "Bidirectional Recurrence Neural Network Imputation For Recovering Missing Daily Streamflow Data," International Journal of Engineering Trends and Technology, Vol. 69 (8), pp. 1-10, 2021.
14. N. Rai and B. Rai, "Neural Network based Closed loop Speed Control of DC Motor using Arduino Uno," International Journal of Engineering Trends and Technology (IJETT), Vol. 4 (2), pp. 137-140, Feb 2013.
15. V. M. Krešňáková, M. Sarnovský, P. Butka, "Deep learning methods for Fake News detection," 2019 IEEE 19th International Symposium on Computational Intelligence and Informatics and 7th IEEE International Conference on Recent Achievements in Mechatronics, Automation, Computer Sciences and Robotics (CINTI- MACRo), Szeged, Hungary, pp. 000143-000148, 2019.
16. N. P. DAHAL and S. SHAKYA, "An Analysis of Prediction of Students' Results Using Deep Learning," Computing Open, 2023. doi: 10.1142/S2972370123500010
17. N. D. Deb, S. Biswas, J. Akhter, A. S. M. "Mostafizur Rahaman, A Hybrid Approach for Android Malicious Software Classification," Computing Open, 2023.
18. P.L. Fernández-Cabán, F.J. Masters, B.M. Phillips, "Predicting Roof Pressures on a Low-Rise Structure From Freestream Turbulence Using Artificial Neural Networks," Front, Built Environ, Vol. 4 (68), 2018.
19. S.B. Adam, "Neural networks," (September 6, 2012).
- O. E. Dragomir, "Contribution to the prognosis of failures by neuro-fuzzy network: control of the prediction error," PhD thesis, Franche-Comte University, 2008



## Artificial Intelligence Models Applied in Predictive Maintenance for Industry 4.0: Analytical and Comparative Study

Youssef Jabari<sup>1</sup>, Imad El Adraoui<sup>2</sup>, Hassan Gziri<sup>1</sup>

<sup>1</sup>Laboratory of Engineering Industrial Management, and Innovation (IMI) Faculty of Sciences and Technology Hassan 1st University, Settat, Morocco.

<sup>2</sup>Materials, Systems and Energy Engineering Laboratory (MaSEEL). Faculty of Sciences and Technology Abdelmalek Essaâdi University, Tangier, Morocco.

### Abstract

Industry 4.0, driven by the convergence of Artificial Intelligence and the Industrial Internet of Things, has revolutionized the way industrial processes, including maintenance, are approached. Preventive maintenance has become a critical strategy for organizations across various industries to minimize downtime, optimize equipment performance, and reduce maintenance costs. The integration of artificial intelligence models has emerged as a promising approach to enhance the effectiveness of predictive maintenance frameworks. Advancements in data analytics and machine learning techniques have enabled the development of robust diagnostic and prognostic maintenance systems that can identify potential failures before they occur. By leveraging these AI-driven approaches, organizations can proactively address equipment issues, leading to improved system reliability, reduced downtime, and enhanced operational efficiency. This paper identifies and examines the role of AI models in the context of preventive maintenance. Furthermore, it will focus on data-driven models, particularly those used for predictive maintenance. These models analyze sensor data, historical maintenance records, and other relevant information to predict equipment failures before they occur. The use of multi-criteria evaluation of these various models provides a wide overview for selecting the most suitable technique for a real diagnostic and prognostic of the industrial system, which will be developed in the perspective.

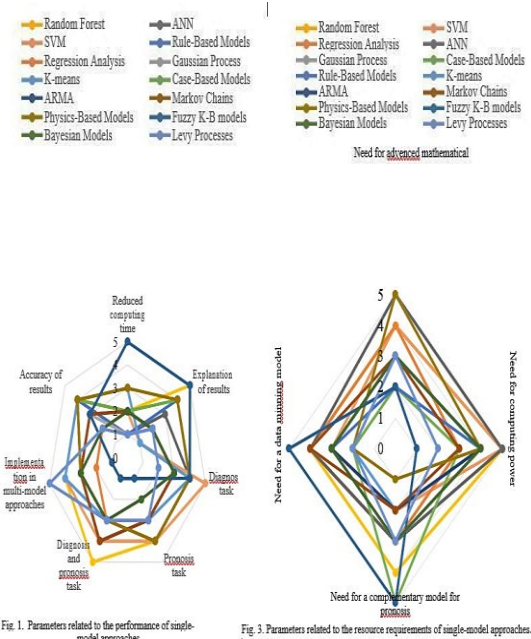

### References

1. J.J. Montero Jimenez, S. Schwartz, R. Vingerhoeds, B. Grabot, M. Salaün, "Towards multi-model approaches to predictive maintenance: A systematic literature survey on diagnostics and prognostics," *Journal of Manufacturing Systems*, vol. 56, Pp. 539-557, 2020.
2. E. Uhlmann, R. P. Pontes, C. Geisert, E. Hohwieler, "Cluster identification of sensor data for predictive maintenance in a selective laser melting machine tool," *Procedia manufacturing* vol. 24, Pp. 60-65, 2018.
3. A. Agnar, E. Plaza, "Case-Based reasoning: Foundational issues, methodological variations, and system approaches," *AI Commun* vol. 7, Pp. 39-59, 1994.
4. J. Z. Sikorska, M. Hodkiewicz, L. Ma, "Prognostic modelling options for remaining useful life estimation by industry," *Mech Syst Signal Process*, vol. 25, no. 5, pp. 1803-1836, 2011.
5. M. S. Haque, M. N. Bin Shaheed, S. Choi, "RUL estimation of power semiconductor switch using evolutionary time series prediction," *IEEE Transp. Electrif. Conf. Expo, ITEC*, pp. 564-569, 2018.
6. D. Zhang, A. D. Bailey, D. Djurdjanovic, "Bayesian identification of hidden Markov models and their use for condition-based monitoring," *IEEE Trans Reliab*, 2016.
7. M. S. Kan, A. C. C. Tan, J. Mathew, "A review on prognostic techniques for non-stationary and non-linear rotating systems," *Mech Syst Signal Process*, vol. 62-63, pp. 1-20, 2015.
8. Z. Zhang, X. Si, C. Hu, Y. Lei, "Degradation data analysis and remaining useful life estimation: a review on Wiener-process-based methods," *Eur J Oper Res*, vol. 271, no. 3, pp. 775-796, 2018.
9. T. P. Carvalho, F. A. A. M. N. Soares, R. Vita, R. D. P. Francisco, J. P. Basto, S. G. S. Alcalá, "A systematic literature review of machine learning methods applied to predictive maintenance," *Elsevier*, pp. 0360-8352, 2019.
10. V. Mathew, T. Toby, V. Singh, B. M. Rao, M. G. Kumar, "Prediction of remaining useful lifetime (RUL) of turbofan engine using machine learning," *IEEE International conference on circuits and systems (ICCS)*, pp. 306-310, 2017.
11. S. Biswal, G. R. Sabareesh, "Design and development of a wind turbine test rig for condition monitoring studies," *International Conference on Industrial Instrumentation and Control (ICIC)*, pp. 891-896, 2015.
12. T. Huuhtanen, A. Jung, "Predictive maintenance of photovoltaic panels via deep learning," *IEEE Data Science Workshop (DSW)*, pp. 66-70, 2018.
13. T. Praveenkumar, M. Saimurugan, P. Krishnakumar, K.I.Ramachandran, "Fault diagnosis of automobile gearbox based on machine learning techniques," *Procedia Engineering*, vol. 97, pp. 2092-2098, 2014.
14. H. Li, D. Parikh, Q. He, B. Qian, Z. Li, D. Fang, A. Hampapur, "Improving rail network velocity: A machine learning approach to predictive maintenance,"

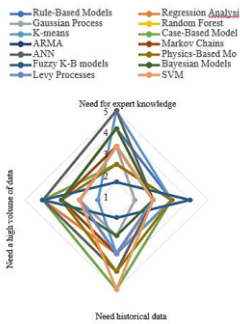

Fig. 2. Parameters related to the reliability of single-model approaches.

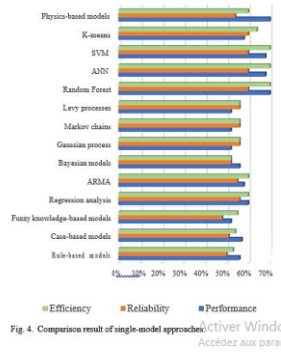

Fig. 4. Comparison result of single-model approaches.

Transportation Research Part C: Emerging Technologies, vol. 45, pp. 17–26, 2014.

15. A. Downey, Y. H. Lui, C. Hu, S. Laflamme, S. Hu, “Physics-based prognostics of lithiumion battery using non-linear least squares with dynamic bounds,” Reliab Eng Syst Saf, vol. 182, pp.1–12, 2019.
16. P. P. Ruiz, B. K. Fogueu, B. Grabot, “Generating knowledge in maintenance from Experience Feedback,” Knowl-Based Syst, vol. 68, pp. 4–20, 2014.
17. D. C. Swanson, “A general prognostic tracking algorithm for predictive maintenance,” IEEE Aerosp. Conf. Proc, 2001.
18. P. Wang, B. D. Youn, C. Hu, “A generic probabilistic framework for structural health prognostics and uncertainty management,” Mech Syst Signal Process, vol. 28, pp. 622–637, 2012.
19. J. Chiachio, M. Chiachio, D. Prescott, J. Andrews, “A knowledge-based prognostics framework for railway track geometry degradation,” Reliab Eng Syst Saf, vol. 181, pp. 127–141, 2018.
20. A. M. Riad, H. K. Elminir, H. M. Elattar, “Evaluation of neural networks in the subject of prognostics as compared to linear regression model,” Int J Eng Technol, vol. 10, pp. 52–58, 2010.
21. I. El Adraoui, Y. Jabari, H. Gziri, “Health Pronosis of a rotating rotor machine with pure unbalance fault using an ANN model,” IREME, vol. 18, no. 3, pp. 144–152, 2024.
22. I. El Adraoui, H. Gziri, A. Mousrij, “Pronosis of a degradable hydraulic system: Application on a centrifugal pump,” IJPHM, vol.13, 2020.



*Youssef JABARI has a bachelor's degree in industrial maintenance from Hassan 1st University, Faculty of Sciences and Technology of Settat, Morocco. He is a Civil Engineer from the Central School of Arts and Crafts (ECAM) in Brussels, Belgium. He has 10 years of experience in Management, Leading construction and technical Projects, and providing solutions in different kind of industries. His area of research is Industry 4.0, Predictive maintenance, AI, and Process Optimization. Currently, he is a PhD at FST, UHP de Settat, Morocco.*

**Email :** [jabari.yousseff@gmail.com](mailto:jabari.yousseff@gmail.com)

GPR for rebar radius estimation in concrete

Hamdaoui Mohammed<sup>1</sup>, Tahar Bachiri<sup>2</sup>, Bendaoued Mohammed<sup>3</sup>, Lakrit Soufian<sup>4</sup> and Faize Ahmed<sup>4</sup>

<sup>1</sup>Mathematics and Information Systems Laboratory, FP of Nador, Mohammed First University, Oujda, Morocco;  
<sup>2</sup>PhD in Civil and Engineering, Faculty of Sciences and Technology, Abdelmalak Essaidi University, Tanger 91001  
<sup>3</sup>LMJET FST of Settat, University of Hassan 1st, Morocco;  
<sup>4</sup>Mathematics and Information Systems Laboratory, EST of Nador, Mohammed First University, Oujda, Morocco;

Abstract

This study aimed to develop a reliable method for determining the radius of a single steel reinforcement embedded in concrete using ground penetrating radar (GPR). GPR, employing high-frequency antennas to transmit short pulses and capture reflected echoes, was utilized to assess internal discontinuities within the concrete structure. The resulting B-scan radargrams were subjected to image processing to extract relevant information. A correlation formula was derived to estimate the rebar radius based on these extracted features. The proposed method demonstrated superior accuracy compared to existing techniques in predicting the rebar radius.

Keywords: B-scan, Concrete, GPR, Radius, Rebar.

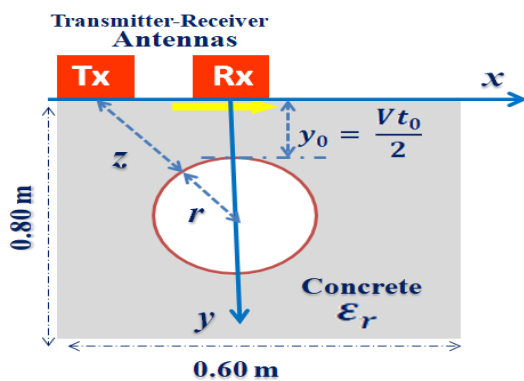
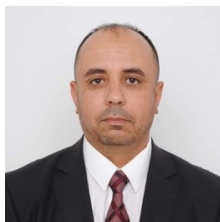

Fig : A buried reinforcing rebar visualized in a B-scan configuration

References

1. Bachiri, T., Khamlichi, A., Hamdaoui, M., Bezzazi, M., & Faize, A. (2024). Numerical modelling of bridge deck reinforcement corrosion based on analysis of GPR data. *International Review of Applied Sciences and Engineering*;
2. Bachiri, T., Alsharahi, G., Khamlichi, A., Bezzazi, M., & Faize, A. (2022). Ground penetrating radar data acquisition to detect imbalances and underground pipes. In *WITS 2020: Proceedings of the 6th International Conference on Wireless Technologies, Embedded, and Intelligent Systems* (pp. 1013-1023). *Lecture Notes in Electrical Engineering*, vol 745. Springer, Singapore;
3. Bachiri, T., Alsharahi, G., Khamlichi, A., Bezzazi, M., & Faize, A. (2020). GPR application in Civil Engineering to search and detect underground Networks. *Int. J. Emerg. Trends Eng. Res.*, 8(5);
4. Bachiri, T., Khamlichi, A., & Bezzazi, M. (2018). Bridge deck condition assessment by using GPR: a review. In *MATEC Web of Conferences* (Vol. 191, p. 00004). EDP Sciences;
5. Bachiri, T., Khamlichi, A., & Bezzazi, M. (2018). Detection of rebar corrosion in bridge deck by using GPR. In *MATEC web of conferences* (Vol. 191, p. 00009). EDP Sciences.



*Dr. Bachiri Tahar is researcher, holding his PhD in Civil Engineering from the Faculty of Sciences and Technologie, Tangier at Abdelmalek Essaidi University, Morocco. His contributions as an author, lecturer, and reviewer for internationally indexed journals in the fields of Applied Sciences and Engineering are recognized. Dr. Tahar's expertise and dedication to his field have led him to actively contribute to the advancement of knowledge and the development of innovative solutions in areas of civil engineering.*

*Email: tbachiri@uae.ac.ma; hamdawimohammedpc@gmail.com*



ID : 142

## Optimizing Parameter Selection in Fuzzy Neural Network for Enhanced Pattern Recognition Using Evolution Strategy

O. El Melhaoui<sup>1,2</sup>, S. Said<sup>1</sup>, Y. Guetbach<sup>3</sup>

<sup>1</sup>.Research Center, High Studies of Engineering School, EHEI, Oujda, Morocco.

<sup>2</sup>. Electronic and System Laboratory, Faculty of Sciences, Mohamed First University, Oujda, Morocco

<sup>3</sup>.LETSER Laboratory, Faculty of Sciences, Mohammed First University, Oujda, Morocco.

### Abstract

Fuzzy Min-Max neural network (FMMNN) is widely recognized for its effectiveness in handling uncertainty and imprecision in classification tasks. However, its performance is significantly influenced by the choice of parameters, which often requires extensive manual tuning. This paper presents an innovative approach that employs Evolution Strategy (ES) for the parameter optimization of FMMNN. The proposed method integrates a population-based optimization technique to automatically adjust key parameters, thereby enhancing classifier performance. An extensive experiment on benchmark datasets is carried out to evaluate the effectiveness of our approach, comparing it against traditional methods. The experimental results indicate a significant improvement in classification accuracy and robustness when using the proposed ES methodology. Moreover, the findings highlight the advantages of employing evolutionary algorithms in optimizing complex fuzzy systems.

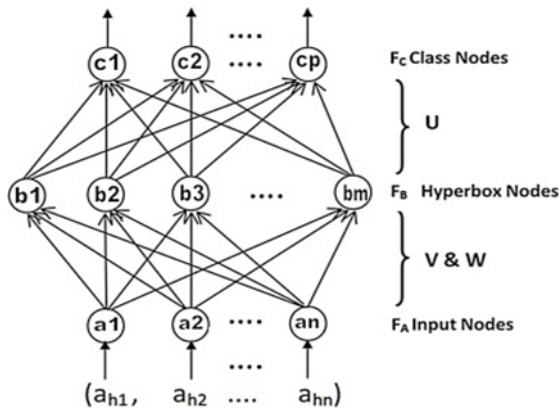

### References

1. Zafar, A., Aamir, M., Nl.awi, N.M., Arshad, A. and Riaz, S., Alruban, A., Kumar Dutta, A. and Almotairi, S. 'A comparison of pooling methods for convolutional neural networks, Applied Science, 12(17) (2022) PP.1-22.
2. Singh, Y. and Susan, S. Lung cancer subtyping from gene expression data using general and enhanced Fuzzy min-max neural networks, Engineering Reports, 5(11) (2022) PP.1-15.
3. Kalbhor, M., Shinde, S., Popescu, D.E. and Hemanth, D.J. Hybridization of deep learning pre-trained models with machine learning classifiers and fuzzy min-max neural network for cervical cancer diagnosis, Diagnostics, 13(7) (2023)1363.



*Ouafae El Melhaoui: was born in Oujda, Morocco in 1981, She received the bachelor and the master degrees in electronics and informatics from University Mohamed Premier of Oujda Morocco in 2004 and 2006 respectively. She is a doctor in physics/classification of data with new signal processing techniques, concept and applications from the faculty of sciences in Mohamed First university, Oujda, Morocco in 2013. Her research includes global optimization, image analysis, machine learning, data mining, pattern recognition, neural network. She has published over 40 papers in international journals and conferences from 2009 to 2024. Her H-index is 5 on Scopus.*

*Email: wafa19819@gmail.com*

## Quantum State Engineering in Two-Spin Systems under Governed by a 3X Heisenberg Model

Brahim Amghar<sup>1</sup>, Mohammed Daoud<sup>2</sup>, Said Dlimi<sup>3</sup>

<sup>1</sup>Laboratory LPNAMME, Laser Physics Group, Department of Physics, Faculty of Sciences, Chouaib Doukkali University, El Jadida, Morocco

<sup>2</sup>Department of Physics, Faculty of Sciences, University Ibn Tofail, Kenitra, Morocco

<sup>3</sup>Laboratory of Sciences and Technologies of Information and Communication (LSTIC), Physics Department, Faculty of Sciences, Chouaib Doukkali University, Route Ben Maachou, El Jadida 24000 Morocco

### Abstract

We consider a two-spin system of 3X Heisenberg type submitted to an external magnetic field. Using the associated CP3 geometry, we investigate the dynamics of the system. We explicitly give the corresponding Fubini-Study metric. We show that for arbitrary pure initial states, the dynamics occurs on a torus. We compute the geometric phase, the dynamic phase and the topological phase. We investigate the interplay between the torus geometry and the entanglement of the two spins. In this respect, we provide a detailed analysis of the geometric phase, the dynamics velocity and the geodesic distance measured by the Fubini-Study metric in terms of the degree of entanglement between the two spins.

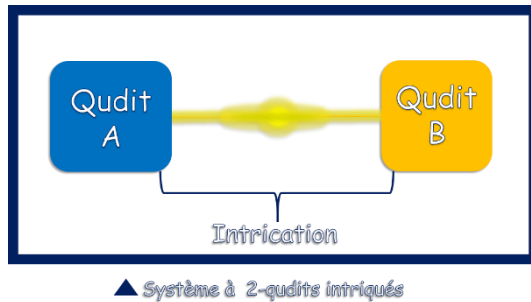

### References

1. B. Amghar and M. Daoud, IJGMMP, 17 (2020), 2050030.
2. B. Amghar and M. Daoud, Phys. Lett. A, 384 (2020), 126682.
3. B. Amghar and M. Daoud, Quant. Inf. Proc, 20 (2021), 1-21.

**Fig: Illustration of the entanglement phenomenon between two electrons (qudits) in a ferromagnetic material**



*I have expertise in quantum effects between subatomic particles and their impacts on the electronic and structural properties of materials. By integrating innovative geometric approaches, we attempt to contribute to new understandings on the manipulation of quantum states, aiming to improve the capabilities of cutting-edge technologies such as quantum computers and advanced electronic devices.*

**Email:** amghar.b@ucd.ac.ma

## Modeling the Moroccan Transmission Network: Data Collection and Simulation

Wafae Arfaoui<sup>1</sup>, Mouad Karmoun<sup>1</sup>, Khaoula Azzakhnini<sup>1</sup>, Mohamed Larbi Elhafyani<sup>1</sup>, Smail Zouggar<sup>1</sup>, Hassan Zahboune<sup>1</sup>, T. Ouchbel<sup>1</sup>, Adrian Alarcon Becerra<sup>2</sup>, and Nikola Matak<sup>3</sup>

<sup>1</sup> University Mohammed I, School of Technology Oujda

Department of Electrical Engineering and Maintenance (LGEM) BP, 473, 60000 Morocco

<sup>2</sup> CIRCE Dinamiza Business Park Ranillas Avenue Building 3D, 1er étage 50018, Saragosse España

<sup>3</sup> University of Zagreb, Faculty of Mechanical Engineering and Naval Architecture, Ivana Lucica 5, 10000 Zagreb, Croatia

### Abstract

The objective of this research project is to systematically collect and model data related to the Moroccan transmission network, with a focus on key infrastructure components such as power plants, substations, and transmission lines. The data for this study are acquired from various open-source platforms, including OpenStreetMap (OSM), OpenInfraMap, and Overpass, and then processed through QGIS software. Due to the difficulty of obtaining detailed and comprehensive data on the Moroccan transmission network, this approach involves leveraging multiple open-source platforms. The dataset includes key attributes such as power plant ratings and geographic coordinates and classifications, substation voltage levels, and transmission line lengths and specific characteristics.

The collected data will then be integrated into GridCal, an advanced software tool designed for power grid modeling, to enable comprehensive simulations of the Moroccan transmission network. Such simulations facilitate detailed analyses of energy flows, grid stability, performance and carrying capacity. The integration of these different information provides a robust framework for modeling, evaluation and optimization of the transmission grid infrastructure. The results of these analyses are expected to provide crucial information for future planning and improvement of the national electricity grid, thus contributing to overall reliability and the energy transition in Morocco.



*I am a Ph.D student candidate at the Laboratory of Electrical Engineering and Maintenance (LGEM), School of Technology, University Mohammed first, Oujda, specializing in Physics & Engineering. With a Master's degree in Electronics, Electrical Engineering, Automation, and Industrial Computing, my research focuses on advanced control systems for renewable energy integration into smart grids. My interdisciplinary background enables me to tackle complex challenges at the intersection of electrical engineering and computer science.*

**Email:** arfaouiwafae2@gmail.com

## Simultaneous Optimization of CNN and KNN Parameters using Genetic Algorithms for Enhanced Shape Recognition

O. El Melhaoui<sup>1,2</sup>, S. Said<sup>1</sup>, Y. Guetbach<sup>3</sup>

<sup>1</sup>.Research Center, High Studies of Engineering School, EHEI, Oujda, Morocco.

<sup>2</sup>. Electronic and System Laboratory, Faculty of Sciences, Mohamed First University, Oujda, Morocco

<sup>3</sup>.LETSER Laboratory, Faculty of Sciences, Mohammed First University, Oujda, Morocco.

### Abstract

Shape recognition plays a critical role in various computer vision applications, where accuracy and efficiency are paramount. This paper proposes a novel hybrid approach combining Convolutional Neural Networks (CNN) for feature extraction, K-Nearest Neighbors (KNN) for classification, and Genetic Algorithms (GA) to optimize the parameters of both CNN and KNN simultaneously. The GA dynamically tunes the CNN's architecture, including the number of layers, filter sizes, stride, activation function and number of zero padding, alongside the KNN's parameters, particularly the value of k for nearest neighbors and distance metrics.

By optimizing both components in parallel, the model achieves improved classification performance and adaptability to different datasets. Experimental results demonstrate the effectiveness of this method on benchmark shape recognition datasets, where it outperforms conventional CNN-KNN models with manually set parameters. This approach underscores the potential of joint parameter optimization in hybrid deep learning frameworks, leading to more robust and accurate shape recognition systems.

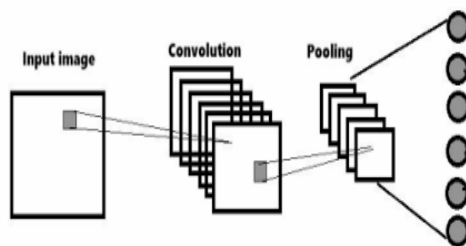

### References

1. Zafar, A., Aamir, M., Nawi, N.M., Arshad, A. and Riaz, S., Alruban, A., Kumar Dutta, A. and Almotairi, S. 'A comparison of pooling methods for convolutional neural networks, Applied Science, 12(17) (2022) PP.1-22.
2. Singh, Y. and Susan, S. Lung cancer subtyping from gene expression data using general and enhanced Fuzzy min-max neural networks, Engineering Reports, 5(11) (2022) PP.1-15.
3. Kalbhor, M., Shinde, S., Popescu, D.E. and Hemanth, D.J. Hybridization of deep learning pre-trained models with machine learning classifiers and fuzzy min-max neural network for cervical cancer diagnosis, Diagnostics, 13(7) (2023)13

Fig : Convolutional neural network



**Ouafae El Melhaoui:** was born in Oujda, Morocco in 1981, She received the bachelor and the master degrees in electronics and informatics from University Mohamed Premier of Oujda Morocco in 2004 and 2006 respectively. She is a doctor in physics/classification of data with new signal processing techniques, concept and applications from the faculty of sciences in Mohamed First university, Oujda, Morocco in 2013. Her research includes global optimization, image analysis, machine learning, data mining, pattern recognition, neural network. She has published over 40 papers in international journals and conferences from 2009 to 2024. Her H-index is 5 on Scopus.

**Email:** wafa19819@gmail.com

## Characterization of the Conductive Properties of TiO<sub>2</sub> for COVID-19 Biosensors: DFT Analysis of the Anatase Phase

Samira Touhtouh<sup>1</sup>, El kebir Hlil<sup>2</sup>

<sup>1</sup> Chouaib Doukkali University of El Jadida, National School of Applied Sciences, Engineering Sciences for Energy Lab, El Jadida, Morocco

<sup>2</sup>Univ. Grenoble Alpes, CNRS, Grenoble INP, Institut Neel, 38000, Grenoble, France

### Abstract

Titanium dioxide (TiO<sub>2</sub>) is a versatile ceramic material widely used in applications such as cosmetics, food products, water and air purification, and the development of self-cleaning surfaces. It exists in three crystalline forms—anatase, rutile, and brookite—with anatase being the most commonly used form for various applications. Producing a pure anatase phase has posed challenges, and the synthesis mechanisms for this phase remain underexplored in the literature. In this article, we present the synthesis process of TiO<sub>2</sub> and detail the formation mechanism of the anatase phase. Additionally, we investigate its potential as a conductive material for biosensing applications through Density Functional Theory (DFT) calculations, with a specific focus on COVID-19 detection. This approach provides insights into the suitability of TiO<sub>2</sub>'s crystalline and conductive properties for enhancing the sensitivity and specificity of COVID-19 biosensors.

**Keywords:** Titanium dioxide, Crystalline forms, Conductive properties, Density Functional Theory, Self-cleaning surfaces



## Exploring the Use of ChatGPT in Event Extraction: Review of Methods and Domain-Specific Enhancements

Mohamed TAYYAUUI , Anass ELHADDADI, TARIK BOUDAA

Laboratory Of Applied Sciences (LSA) ENSAH, Abdelmalek Essaâdi University (UAE) Tetouan, Morocco

### Abstract

This paper provides a comprehensive review of event extraction using large language models (LLMs), with a particular emphasis on the behavior of ChatGPT compared to fine-tuned models. Event extraction is a vital task in natural language processing (NLP) that entails detecting and categorizing events in textual data. Traditional methods have encountered various limitations, prompting the adoption of advanced LLMs like GPT-3, of which ChatGPT is a variant. This review examines the methodologies and results of previous studies that have employed GPT models, highlighting their performance in event extraction tasks. We compare ChatGPT's capabilities with those of models specifically fine-tuned for event extraction, providing insights into their strengths, weaknesses, and practical implications. Our findings shed light on the capabilities of generative pre-trained transformers in improving the accuracy and efficiency of event extraction, while also identifying areas where further research and development are needed. Through this comparative analysis, we aim to guide future research directions and applications in the domain of event extraction using LLMs.

### References

1. G. Jacobs et V. Hoste, « Extracting Fine Grained Economic Events from Business News ».
2. Saroj, « Rule Based Event Extraction System from Newswires and Social Media Text in Indian Languages (EventXtract-IL) for English and Hindi data ».
3. Li, L. Huang, H. Ji, et J. Han, « Biomedical Event Extraction based on Knowledge-driven Tree-LSTM ».
4. G. Doddington, A. Mitchell, M. Przybocki, L. Ramshaw, S. Strassel, et R. Weischedel, « The Automatic Content Extraction (ACE) Program Tasks, Data, and Evaluation ».
5. J. Pustejovsky et al., « The Specification Language TimeML », in The Language Of Time, I. Mani, J. Pustejovsky, et R. Gaizauskas, Éd., Oxford University PressOxford, 2005, p. 545-558. doi: 10.1093/oso/9780199268535.003.0031.
6. N. Haffar et M. Zrigui, « A Synergistic Bidirectional LSTM and N-gram Multi channel CNN Approach Based on BERT and FastText for Arabic Event Identification », ACM Trans. Asian Low-Resour. Lang. Inf. Process., vol. 22, no 11, p. 1-27, nov. 202.
7. S. Almasian, D. Aumiller, et M. Gertz, « BERT got a Date: Introducing Transformers to Temporal Tagging ».
8. J. Gao, H. Zhao, C. Yu, et R. Xu, « Exploring the Feasibility of ChatGPT for Event Extraction ».
9. M. Choudhary et X. Du, « QAEVENT: Event Extraction as Question-Answer Pairs Generation ».
10. R. Chen, C. Qin, W. Jiang, et D. Choi, « Is a Large Language Model a Good Annotator for Event Extraction? », AAAI, vol. 38, no 16, p. 17772-17780.
11. Z. Wang et al., « CLEVE: Contrastive Pre training for Event Extraction ». arXiv, 30 mai 2021. Consulté le: 15 mai 2024.
12. Y. Lu et al., « Text2Event: Controllable Sequence-to-Structure Generation for End-to end Event Extraction ».
13. Z. Sun, G. Pergola, B. C. Wallace, et Y. He, « Leveraging ChatGPT in Pharmacovigilance Event Extraction: An Empirical Study ».
14. J. Gao, H. Zhao, W. Wang, C. Yu, et R. Xu, « EventRL: Enhancing Event Extraction with Outcome Supervision for Large Language Model ».
15. Y. Hao, Y. Liu, et L. Mou, « Teacher Forcing Recovers Reward Functions for Text Generation ».



Author has expertise in Artificial Intelligence (AI) and Natural Language Processing (NLP)

Email: [mohamed.tayyauui@gmail.com](mailto:mohamed.tayyauui@gmail.com)





---



# Posters

---



## Energy performance of building walls incorporating PCMs

Soukaina Toumzine, Hanane moulay abdelali

Mohammed V University in Rabat, Mohammadia School of Engineering, Civil Engineering and Construction Laboratory, Avenue Ibn Sina B.P 765, Agdal, Rabat, 10090, Morocco

### Abstract

Energy consumption is subject to increase due to population growth, the creation of new cities, and the sustained use of air conditioning and heating systems in Morocco. In this regard, research is focused on developing innovative, environmentally friendly materials capable of generating significant energy savings, called phase change materials (PCMs).

The current study aims to numerically investigate the improvement of the energy performance of a residential building located in Meknes by integrating phase change materials (PCMs) compared to a conventional building that complies with the RTCM thermal regulation. The PCMs used in this research are bio-based PCMs available on the market.

A numerical simulation will be carried out using the Energy Plus software to choose the optimal PCM in terms of its location and general thermophysical properties. Then, the economic feasibility of implementing PCM in building envelopes is evaluated through static and dynamic payback period calculations for this type of climate.



*Soukaina Toumzine* received a civil engineer diplomate from ENSAM-Meknes (2019). I am currently pursuing Phd degree in Mohammadia School of Engineering, Civil Engineering and Construction Laboratory, Mohammed V University in Rabat. My research interest the impact of PCMs integrated into the building envelope to limit heating and cooling energy consumption.

One of my key accomplishments includes participating in the 8th Franco-Maghreb Scientific Days (JSFM-CMC), where I presented a written communication (poster) on the characterization of complex materials (phase change materials PCMs). Additionally, I submitted my first article titled Phase Change Materials (PCMs) Used in Buildings: A Critical Review.

**Email:** soukaina.toumzine@research.emi.ac.ma

## Literature review on the reinforcement of self-compacting concrete by plant fibers

Maryem Bali, Hanane Moulay Abdelali, Toufik Cherradi

Mohammed V University, Mohammadia School of Engineering, Rabat, Morocco

### Abstract

Self-compacting concrete (SCC) is a construction material designed to fill complex and congested formwork without requiring vibrations to consolidate the mixture, which makes it particularly useful in situations where traditional compaction methods are impractical, and it is typically used in heavily reinforced structures where mechanical properties are crucial. To enhance these properties, different types of fibers are incorporated, creating a strong and durable composite construction material.

In this presentation, we started with a comprehensive overview of self-compacting concrete and its most well-known formulation methods. Subsequently, based on state-of-the-art research, we introduced and examined a study on natural plant fibers, including their origins, chemical, physical, and mechanical properties, as well as various extraction methods and treatment techniques. Finally, we explored the impact of various natural plant fibers on the performance and characteristics of self-compacting concrete. This led to the main objective of this paper, which is to demonstrate that reinforcing self-compacting concrete with plant fibers yields positive results in various aspects, potentially providing an alternative to industrial fibers.

The different experiments revealed promising results, encouraging a growing interest in the use of plant fibers in construction materials, particularly in self-compacting concrete. This growing trend is contributing to the creation of a new wave of eco-friendly and sustainable building materials.

**Keywords:** self-compacting concrete, plant fibers, fibers treatment, mechanical properties.

### References

1. Okamura, H & Ouchi, M. (2003). Self Compacting Concrete. Journal of Advanced Concrete Technology, vol 1, no 1.
2. Sedran, T., & De Larrard, F. (1999). Optimization of self-compacting concrete thanks to packing model. Proceedings 1st SCC Symp, CBI Sweden, RILEM PRO7, p. 321-332
3. Turcry, P., & Loukili, A. (2003). Différentes approches pour la formulation des bétons autoplaçants: Influence sur les caractéristiques rhéologiques et mécaniques. Revue Française de Génie Civil, vol. 7, no 4, p. 425-450.
4. Shi, C., Wu, Z., Lv, K., & Wu, L. (2015). A review on mixture design methods for self compacting concrete. Construction and Building Materials, vol. 84, p. 387-398.



*Maryem Bali is a civil engineer who completed her undergraduate studies at the National School of Applied Sciences (ENSA). Currently, she is pursuing a PhD at the Laboratory of Civil Engineering and Construction (GCC) at the Mohammadia School of Engineers (EMI), where her research centers on reinforced concrete incorporating plant fibers.*

*In 2023, she had the privilege of participating in the Franco-Maghrebian Scientific Days on the Characterization of Complex Materials (JSFM-CMC).*

*Email: maryem.bali@research.emi.ac.ma*

## Exploring the Moroccan Population's Views and Awareness of Organic Food

Soumaya Atouife, Abdelghani Aboukhalaf, Jamila Elbiyad, Seloua Essaih, KaoutarNaciri, Adil

Kalili, Abdellah El Habazi, and Rekia Belahsen

*Training and Research Unit on "Nutrition Food Science", LABS. Faculty of Sciences, Choua'ib Doukkali University – Morocco*

### Abstract

In recent decades, shifts in food production and consumption patterns have emerged, impacting significantly the food system and having repercussions on both the environment and health. These changes are largely driven by an increased food production to meet the needs for food security and global population growth. This surge in production has, in turn, influenced people's eating habits, enhancing food availability and improving food security. All these changes are also causing negative environmental consequences such as the depletion of natural resources, deforestation, biodiversity loss, pollution, climate change, water scarcity, and air quality degradation, among others. At the same time, unsustainable food consumption exacerbates these imbalances in terms of both quantity and quality, intensifying the effects during and after the COVID-19 health crisis on human health and environmental sustainability. In this context, organic agriculture emerges as a promising alternative to promote sustainable food consumption. This paper aims to assess Moroccans' perception of organic agriculture through an online questionnaire, to which 423 participants responded. The results reports that 81.7% of survey respondents consumed organic foods for reasons mainly related to their benefits on health environment, 85.5% claimed the high cost as reason for not eating them. The study revealed also a confusion of organic products with local products in a large part of the participants (66.3%). In conclusion, Moroccan population perceives organic food superior to conventionally grown products in terms of quality or taste. However, the consumption of organic products is still modest or even low among the population. The data from this study indicate that although the development of organic agriculture is still insufficient in Morocco, it appears to be a promising approach for sustainable food consumption.

**Keywords:** Sustainable food, organic food, local food, consumption, perception, Morocco



ID :109

## Study of the dynamics of seagrass *Cymodocea nodosa* in Al Hoceima Marine Protected Area

**Karim Souhail***Faculté des sciences techniques d'al Hoceima – Morocco*

### Abstract

Seagrass meadows are crucial coastal ecosystems due to their diverse ecological roles and services they offer. However, there has been a significant decline in these habitats worldwide, emphasizing the need for comprehensive studies to monitor and map them across their range. In Al Hoceima National Park, *Cymodocea nodosa* is the sole seagrass species reported, yet reliable information about its distribution is scarce. This study unveils the presence of a persistent *C. nodosa* patch on PNAH and explores its ecological and biological characteristics, such as density, leaf length, and associated flora and fauna. Through three years of seasonal monitoring, the study reveals an expansion in the patch's size and shoot density, with leaf lengths displaying a typical seasonal fluctuation. Given past incidents of seagrass destruction on the MPA, continuous monitoring of this patch and its surroundings is essential to understand its development, whether it merges into a larger meadow, and how anthropogenic activities like coastal development and sediment runoff may impact its resilience. *Cymodocea nodosa* is a species of marine plant belonging to the Cymodoceaceae family. It is widely distributed in coastal habitats of warm and temperate seas around the globe. This species plays a crucial role in marine ecosystems by providing habitat, stabilizing sediments, promoting biodiversity and participating in biogeochemical processes.

**Keywords:** *Cymodocea nodosa*, seagrass, marine protected areas



ID : 117

**Advanced applications of metal-organic frameworks: Green hydrogen production, energy storage, and environmental remediation for sustainable development****Essifi Kamal<sup>1</sup>, Abdelqader El Guerraf<sup>2</sup>, Mohamed Brahmi<sup>3</sup>, Abdelouahab El Hadrami<sup>1</sup>, Rachid Brahmi<sup>1</sup>, Amine Moubarik<sup>4</sup>, Abdesselam Tahani<sup>3</sup>**<sup>1</sup>Coordination and Analytical Chemistry Laboratory, Faculty of Sciences, University of Chouaib Doukkali, El Jadida, Morocco.<sup>2</sup>Laboratory of Applied Chemistry and Environment, Faculty of Sciences and Techniques, Hassan First University, 26002 Settat, Morocco<sup>3</sup>Physical Chemistry of Natural Resources and Process Team, Laboratory of Applied Chemistry and Environment, Department of Chemistry, Faculty of Sciences, University Mohamed Premier, Oujda, Morocco.<sup>4</sup>Chemical Processes and Applied Materials Laboratory, Polydisciplinary Faculty, Sultan Moulay Slimane University, 23000 Beni-Mellal, Morocco.**Abstract**

This project explores the innovative applications of metal-organic frameworks (MOFs) to address critical challenges in energy production, storage, and environmental sustainability. One of the primary focuses is the production of green hydrogen through water splitting, a pivotal technology for the future of renewable energy. By optimizing MOF-based catalysts, the project aims to enhance the efficiency of photoelectrochemical reactions, thereby contributing to clean energy transition goals and supporting Morocco's efforts to reduce reliance on fossil fuels. Additionally, the research investigates the potential of MOFs in energy storage systems, particularly for lithium-ion batteries. Thanks to their unique porous structures, MOFs can improve electrode performance, offering higher storage capacity and enhanced stability. These advancements align with the growing demand for efficient batteries in electric vehicles and renewable energy storage systems. The project also addresses pressing environmental challenges by developing solutions for water pollution treatment. By incorporating MOFs into composite materials, the research aims to create highly effective adsorption systems for removing organic pollutants, contributing to water quality improvement—a critical issue in Morocco, which faces significant water resource management challenges.

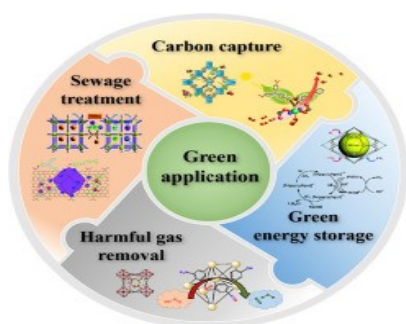
**References**

1. Essifi, K., Brahmi, M., Ed-Daoui, A., Boussetta, A., Benelmostafa, M. H., Dahmani, M., Salhi, S., Moubarik, A., El Bachiri, A. & Tahani, A. (2023). International Journal of Biological Macromolecules, 242, 125011.
2. Brahmi, M., Essifi, K., Bakirhan, N. K., El Bachiri, A., Ouldriane, S. D., & Tahani, A. (2023). Journal of Molecular Liquids, 387, 122635.
3. Essifi, K., Hammani, A., Berraouan, D., El Bachiri, A., Fauconnier, M. L., & Tahani, A. (2022). Materials Chemistry and Physics, 277, 125569.



**Kamal Essifi** holds a PhD in Physical Chemistry and Materials Science, earned in 2022. He is currently an Assistant Professor at the Faculty of Sciences - Chouaib Doukkali University. His research focuses on the development of advanced hybrid materials for various applications, including the encapsulation and controlled release of active substances. He has more than 20 papers in the field with over 200 Citations.  
For inquiry, please contact in:

**Email:** [kamal.essifi.lpapc@gmail.com](mailto:kamal.essifi.lpapc@gmail.com)



## Modeling Proton Ionization Cross Sections for DNA Bases: Insights for Radiation Therapy Optimization

M.L BOUHSSA<sup>1</sup>, F. ARHOUNI<sup>1</sup>, S. OUAKKAS<sup>1</sup>, N. HARAKAT<sup>1</sup>, A. BOUKHAIR<sup>2</sup>

<sup>1</sup>Laboratory of Nuclear, Atomic, Molecular, Mechanical and Energetic Physics, Department of physics, 24000, El Jadida, Morocco

<sup>2</sup>Regional center of the Trades of Education and Training, Casablanca-Settat, Morocco

### Abstract

This study investigates the modeling of proton ionization cross sections for DNA bases—guanine, adenine, thymine, and cytosine—addressing the increasing interest in the interactions of charged particles with biological molecules. By employing the semi-empirical Rudd formula, we enhance the understanding of radiation damage mechanisms. Additionally, we incorporate results from water targets to examine excitation and charge-changing processes, providing valuable insights into proton interactions with biological tissues, particularly in the context of radiation therapy. Our analysis of the Bragg peak position profile across a range of proton energies is critical for optimizing therapeutic applications. The strong correlation of our findings with Monte Carlo methods, GEANT4-DNA, and SRIM toolkits underscores the reliability of our model.

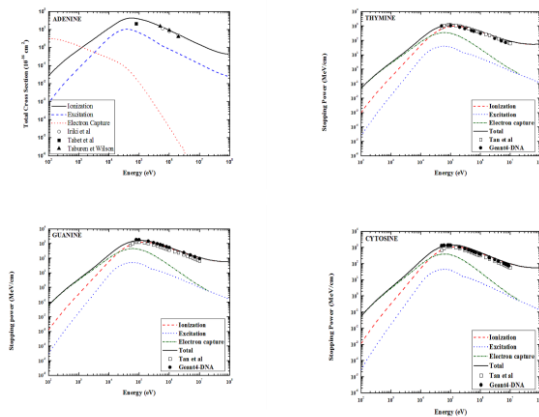

### References

1. Rudd M E 1989 Nucl. Tracks Radiat. Meas. 16 213.
2. Tabet J, Eden S, Feil S, Abdoul-Carime H, Farizon B, Farizon M, Ouaskit S and Mark T D 2010. Phys. Rev. A 82 022703
3. Iriki, Y., Kikuchi, Y., Imai, M., and Itoh, A., Absolute doubly differential cross sections for ionization of adenine by 1.0-MeV protons, Phys. Rev. A 84, 032704 (2011a).
4. Z. Francis, et al. Calculation of lineal energies for water and DNA bases using the Rudd model cross sections integrated within the Geant4-DNA processes, J. Appl. Phys. 122, 014701 (2017).
5. ICRU 1993 Stopping Powers and Ranges for Protons and Alpha Particles (Bethesda, MD: ICRU).

**Fig: Total cross sections for the main interaction processes for proton impact with four nucleobases of DNA.**



Expertise in nuclear structure, simulation and modeling of beam line massseparator with GEANT4 software, ROOT.

Email: [Bouhssa.m@ucd.ac.ma](mailto:Bouhssa.m@ucd.ac.ma)

ID:185

## Synthesis and Characterization of CuO Thin Films on Glass, ITO, and FTO Substrates Using Spin-Coating for Photovoltaic Applications

Nouhaila BENAÏSSA<sup>1</sup>, Taoufik Garmim<sup>1</sup>, Zouhair El Jouad<sup>1</sup>, Ahmad Louardi<sup>2</sup>, Mohamed Monkade<sup>1</sup>

<sup>1</sup>Laboratory of condensed Matter Physics (LPMC), Department of Physics, Faculty of Sciences, Chouaïb Doukkali University, El-Jadida, Morocco

<sup>2</sup>Laboratory of Industrial Techniques, Department of Industrial Engineering, Faculty of Sciences and Techniques, Sidi Mohamed Ben Abdellah University, Fez, Morocco

### Abstract

In this work, copper oxide (CuO) thin films were successfully deposited on three different substrates—glass, indium tin oxide (ITO), and fluorine-doped tin oxide (FTO)—using the spin-coating method. Structural, optical, and vibrational properties of the films were analyzed through X-ray diffraction (XRD), UV-visible spectroscopy, and Raman spectroscopy. XRD results confirmed the crystalline nature and phase purity of the CuO films, with substrate effects on crystallite orientation and size. UV-visible spectroscopy provided insights into optical properties, including band gap variations across different substrates. Raman analysis validated the formation of the CuO phase and highlighted the vibrational modes, showing uniformity and good adherence. These findings reveal how different substrates influence the properties of spin-coated CuO thin films, supporting their application in optoelectronic and photovoltaic devices.



*Phd student at 5<sup>th</sup> year expertise extends to surface analysis and optical characterization, providing valuable insights into the structural integrity and light absorption capabilities of CuO thin films.*

**Email:** [benaisa.n@ucd.ac.ma](mailto:benaisa.n@ucd.ac.ma)

ID :200

## The agro-food industry valorization of Cannabis

Hajar Soujaa, Chaymae El Youssfi, Ouafae Zerrad, Mohammed Rami, Saida Aarab, Mohammed Hassani Zerrouk

*Laboratory of Research and Development in Engineering Sciences, Faculty of Science and Technology Al Hoceima, University Abdelmalek Essaadi, Morocco*

### Abstract

The research explores the opportunities presented by the Cannabis plant (*Cannabis sativa*) in the agro-food industry, particularly in the Morocco context market by the recent adoption of new legislation regulating Cannabis-related activities. This legislative development opens new perspectives for the responsible and innovative use of cannabis bioactive compounds in food products. The objective is also to evaluate the compatibility of these extracts with a variety of food products, considering regulatory requirements and consumer expectation.

The study focuses on a thorough analysis of the physiochemical properties of these compounds, aiming to optimize extraction and purification methods. The objective is also to evaluate the compatibility of these extracts with a variety of food products, considering regulatory requirements and consumer expectations.

**Keywords:** Cannabis sativa, agro-food, extraction, legislative development.

### References

1. Rasera GB, Ohara A, de Castro RJS. Innovative and emerging applications of cannabis in food and beverage products : Food an illicit drug to a potential ingredient for health promotion. Trends Food Sci Technol. (2021) 115:31-41. Doi : 10.1016/j.tifs.2021.06.35
2. Farinon B, Molinari R, Costantini L, Merendino N. The seed of industrial hemp (*cannabis sativa* L): nutritional quality and functionality for human health and nutrition. Nutrients. (2020) 12: 1935. Doi : 10.3390/nu 12071935



## AI-Driven Bridge Rehabilitation: Enhancing Infrastructure through Predictive Analytics

Salma Ouhmida <sup>1</sup>, Hanane Moulay Abdelali <sup>2</sup>

<sup>1</sup> Université Mohammed V de Rabat, Ecole Mohammadia d'Ingénieurs,

<sup>2</sup> LGC, Construction. Avenue Ibn Sina B.P 765, Agdal, Rabat 10090, Morocco

### Abstract

Maintaining and rehabilitating critical structures like bridges as infrastructure ages is becoming increasingly important. Bridges are essential components of modern infrastructure and, require frequent rehabilitation to ensure safety and longevity. Traditional inspection methods, which can be time-consuming, labor-intensive, and costly, are prone to delays that may jeopardize structural integrity. In this context, integrating Artificial Intelligence (AI) provides an innovative approach to streamlining inspection and maintenance processes.

This research investigates the application of AI algorithms, including Artificial Neural Networks (ANN), Recurrent Neural Networks (RNN), and Support Vector Regression (SVR) to predict the best bridge rehabilitation strategy and recommends timely interventions. By analyzing real-time data collected from sensors embedded in bridge structures, we aim to optimize predictive maintenance strategies. This interdisciplinary research merges various engineering disciplines: mechanical engineering principles are employed for structural analysis, while environmental engineering data assesses weather-induced degradation. Electrical engineering contributes to sensor technology and data acquisition systems that monitor structural health in real-time, and software engineering underpins the development of predictive algorithms and simulation tools for real-time decision-making. The nature of this research helps reduce human error, improve decision-making speed, and enhance safety.

Preliminary results indicate that the AI models achieved high accuracy in predicting potential rehabilitation strategies, significantly reducing inspection times and minimizing the need for costly manual evaluations. This AI-driven approach enhances the reliability of mechanical components within bridges and improves the efficiency of monitoring systems powered by electronic and electromagnetic devices. Furthermore, it supports environmental sustainability by reducing the materials and energy required for frequent repairs.

This work demonstrates the potential of AI to revolutionize bridge rehabilitation and offers valuable insights for engineers, urban planners, and policymakers. By paving the way for smarter, more resilient infrastructure systems worldwide, this research serves as a blueprint for integrating smart technologies into civil infrastructure.

**Keywords:** AI, bridge rehabilitation, predictive maintenance, structural health monitoring, machine learning.

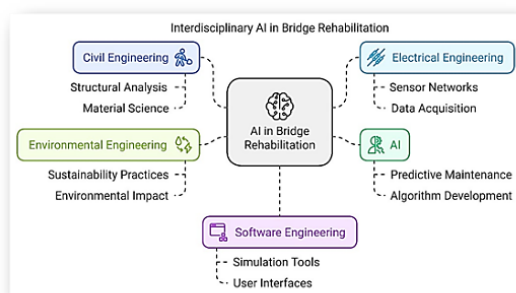

### References

- Xie, M., Fan-bing, M., Zou, J., Feng, W., & Ma, S. (2020, June 1). Application of Artificial Intelligence in Civil Engineering Education. IOP Publishing, 1575(1), 012225-012225. <https://doi.org/10.1088/1742-6596/1575/1/012225>
- Chen, Z., Wu, Y., Li, L., & Sun, L. (2015, January 1). Application of Artificial Intelligence for Bridge Deterioration Model. <https://doi.org/10.1155/2015/743643>
- Zhang, G., Wang, B., Li, J., & Xu, Y. (2022, December 7). The application of deep learning in bridge health monitoring: a literature review. Springer Nature, 3(1). <https://doi.org/10.1186/s43251-022-00078-7>
- Marchewka, A., Ziółkowski, P., & Aguilar, V. (2020, January 27). Framework for Structural Health Monitoring of Steel Bridges by Computer Vision. <https://doi.org/10.3390/s20030700>
- Bidollahkhani, M., & Kunkel, J. (2024, April 20). Revolutionizing System Reliability: The Role of AI in Predictive Maintenance Strategies. Cornell University. <https://doi.org/10.48550/arXiv.2404>



**Salma Ouhmida** is a civil engineer and a 3rd-year PhD student in the Civil Engineering department at the Mohammadia School of Engineering. Her research focuses on the application of artificial intelligence for bridge rehabilitation, aiming to improve the prediction of structural health and optimize maintenance strategies. Through her work, she explores the integration of AI models with real-time data from sensors to enhance infrastructure resilience and safety.

**Email:** Salma1998ouhmida@gmail.com

ID : 90

**Electrical Performance of 3D-Printed PLA Composites with Carbon Black****Nassima Naboulsi, Fatima Majid, and Taoufik Hachimi***Laboratory of Nuclear, Atomic, Molecular, Mechanical and Energetic Physics, Chouaib Doukkali University, El jadida, – Morocco***Abstract**

Conductive polylactic acid (PLA) is an innovative composite material that combines the environmental advantages of PLA as a biodegradable thermoplastic with its electrical conductivity properties. PLA has always been widely used in additive manufacturing due to its simple processing, low cost and environmentally friendly profile. However, the application of PLA has been limited to non-electrical contexts due to its insulating nature. The introduction of conductive PLA, which is usually obtained by integrating conductive fillers such as carbon nanotubes or carbon black into the PLA matrix, offers new possibilities for functional applications. This material maintains the biodegradability and printability of traditional PLA, while enabling the manufacture of components with electrical conductivity. This material not only allows the manufacturing of electrically conductive components, but also maintains the biodegradability and printability of traditional PLA. This study focuses on the mechanical behavior and damage analysis of conductive PLA material through a series of tensile tests performed on standardized samples. The aim is to explore the impact of different crosshead speeds on the material's tensile properties and fracture mechanisms, and to analyze how strain rate affects the mechanical performance of conductive PLA, offering an approach for its use in additive manufacturing applications that require specific mechanical behaviors under varied loading conditions.

**Keywords:** PLA, Conductive, mechanical behavior, damage analysis, additive manufacturing.



ID :112

## The impact assessment of a magnetic field dedicated to MRI during a carbon-therapy on treatment efficiency

Ayoub Marhou, Mohammed Hamal, Abdelkarim Bazza, and Mustapha Zerfaoui

University of Mohammed I - Universit'e Mohammed Premier – Morocco

### Abstract

**Purpose:** To evaluate decreasing and increasing dose rates along the carbon ion beam propagation axis for each Z-axis value and the beam deviation, as well as the displacement of dose-profile curves with respect to the lateral axis in a perpendicular magnetic field of MRI machine.

**Methods:** a carbon ion beam was delivered on a voxelized phantom of rectangular geometry simulated by applying the GEANT4 simulation code. The beam deviation was calculated for a 270 MeV/u beam energy for three different magnetic fields of 0.35, 1.5 and 2 T. While the rates of decrease and increase in dose, as well as lateral shifts of dose profiles were performed in the presence of 1.5 T magnetic field.

**Results:** Our Bragg depth did not change by applying a 1.5 T magnetic field under 270MeV/u energy. The analysis results include Bragg-curves at different off-axis positions, the Rate of Decreasing-Dose (RDD), the Rate of Increasing-Dose (RID), Lateral Dose-Profile as well as the lateral deflection of the primary beam dose-profile along the X-axis. These results show a decreasing dose of 45.919% at the treatment field center and a lateral displacement of 4.57675 mm by applying a 1.5 T magnetic field. The findings further show that the displacement variation as a function of the magnetic field at the Bragg peak area obeys a linear law (a straight-line).

It is necessary to take into account the displacement of 4.57675 mm when applying a 1.5 T magnetic-field during a treatment with carbon ions combined with magnetic resonance imaging.

**Keywords:** Bragg peak, Dose, Magnetic Field, Lateral profile, PDD





## Neotectonic structures of the north central rif ( Morocco ) : Contribution of digital Mapping data

Achraf Moqaddem, Mohamed Makkaoui, Omar Azzouz

Applied Geosciences Laboratory, Faculty of sciences, Mohamed Premier University, Oujda

### Abstract

The structuring of the Rif chain is determined by an exaggeration of the metamorphic, scaling and sliding deformations associated with the main orogenic phases of the Oligocene, Burdigalian and Tortonian. While the shaping of its contrasting and rugged relief is dictated by epirogenic movements of lesser importance associated with the persistence of the African-European rapprochement. This neotectonic instability is driven by essentially brittle deformations accommodated by the reactivation of pre-existing structures. Hence the interest of this morpho-structural study, which highlights the contribution of digital mapping data to the characterization and assessment of these recent and active deformations. In the context of this work, which concerns the north-central part of the Rif mountain range, the first step was to identify and prioritize all the ridge lineaments, the hydrographic network and the coastlines. These data were compared with the analysis of slopes and the information provided by the geometric layout of the various tectonic depressions marked by isolated accumulations of Plio-Quaternary deposits. The structural diagram we've drawn enables us to identify the various regional faults that have shaped these morpho-structural reliefs. We classify them into 3 coherent deformation systems whose specific tectonic attitudes and behavior correspond to the 3 respective episodes of the Plio-Villafranchian, Quaternary and present-day.

**Keywords:** Rif, deformation , neotectonics , plio-quaternary , mapping

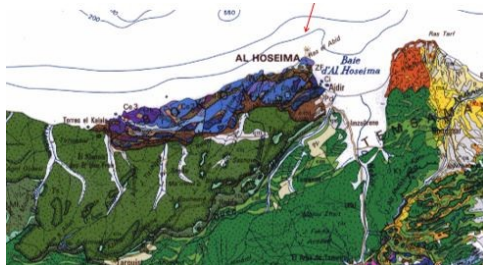

### References

1. Choubert, G.; Marçais, J.; Suter, G. Carte géologique du Maroc au 1/500,000, feuille de Oujda. Notes Mém. Serv. Géol. 1956, Maroc, n° 70.
2. Suter, G. Carte structurale du Maroc au 1/500,000, feuille de Rif. Notes Mém. Serv. Géol. 1980, Maroc.

**Fig: Extract from the 1:500,000 Central-North Rif geological map**



Author is a Phd Candidate in Applied Geosciences , specializing in structural geology . Currently , I serve as an administrator at the Higher School of Technology in Nador. I also lecture in Civil Engineering and Environmental and Water Sciences , with expertise in Geosciences and Civil Engineering. My academic and professional activities bridge applied research and teaching in these fields.

**Email:** achraf.moqaddem@ump.ac.ma